

Return Line Filters • Suction Line Filters • In-Line Filters • Service Instructions • Accessories



Donaldson Delivers Performance Under Any Pressure!

Clean, dry oil is essential for your equipment.

Donaldson Company, a leader in filtration solutions for 100 years, has proven performance in thousands of applications – offering the industry's largest selection of replacement hydraulic, lube and gear oil filtration products for contamination control.

Distributed by:

Medium and high pressure filters

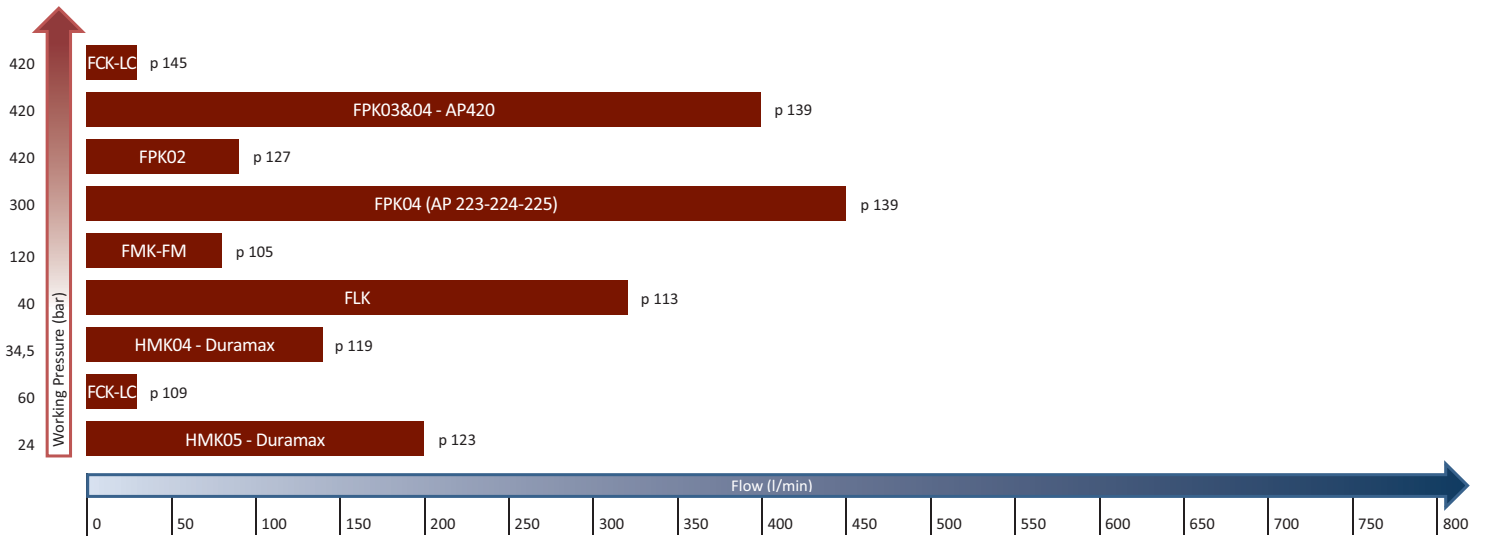

Return line filters

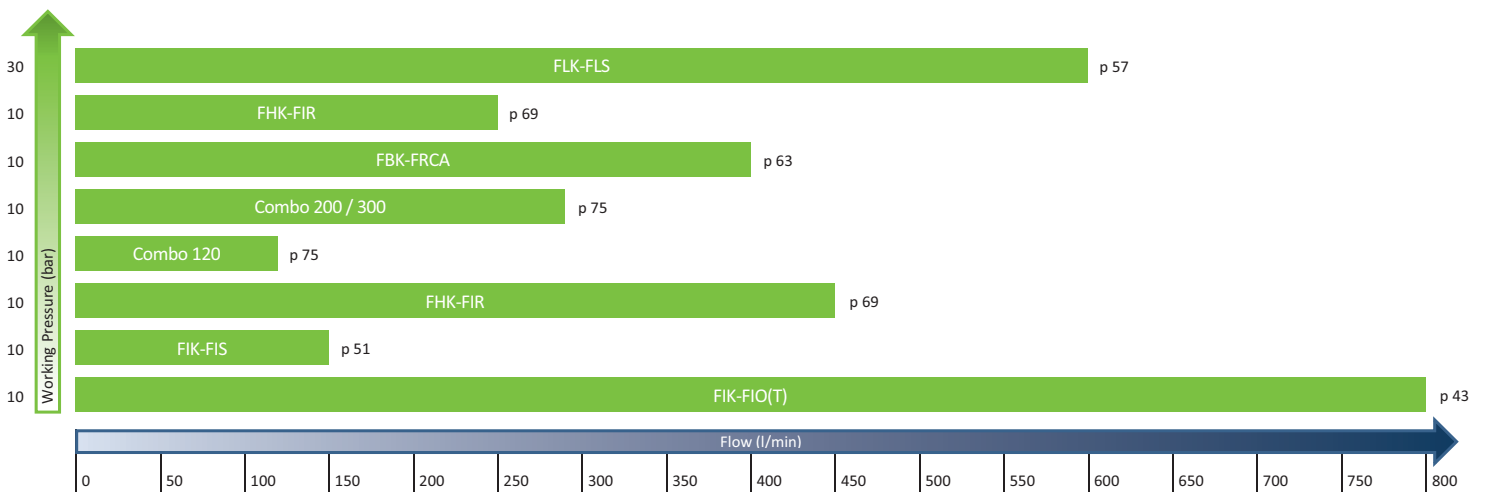

Suction line filters

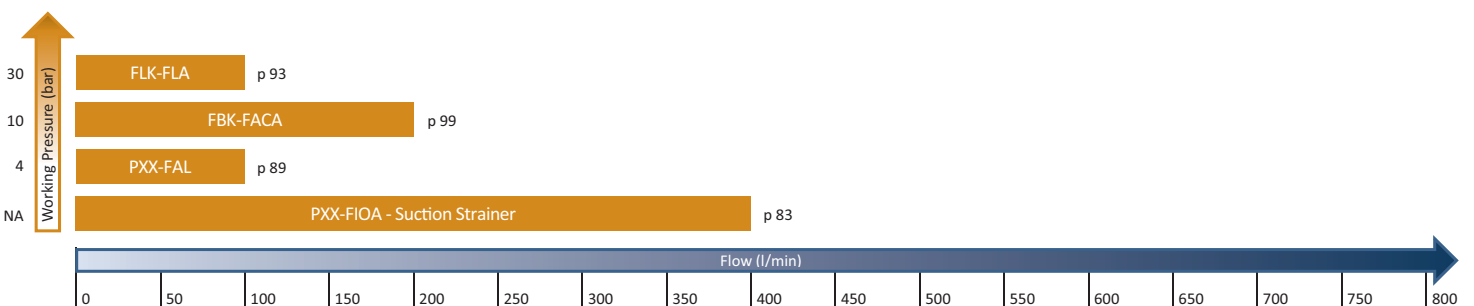

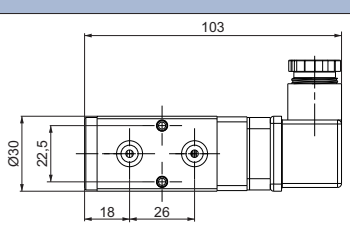
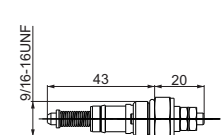
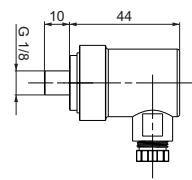
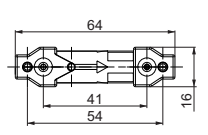
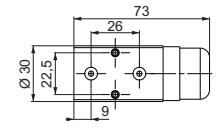
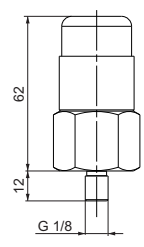
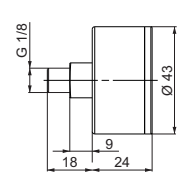
Part	Kind		Reference Drawing	Setting (bar)	Contact	Protection Class	Cable Clamp	Max. Values	Remark	
P171963	Electrical	Differential	A	1,4	Normally Open (3) / Closed (2)	IP65	PG11 - DIN 43650	30 VAC - 30 VDC; 0,5 A res. and 0,2 A ind.	with thermostat at min. temperature at 30°C	
P171961	Electrical	Differential	A	1,4	Normally Open (3) / Closed (2)	IP65	PG11 - DIN 43650	30 VAC - 30 VDC; 0,5 A res. and 0,2 A ind.		
P163839	Electrical	Differential	B	1,25	Normally Closed			6-30 V DC; 0,2 A		
P162400	Electrical	Differential	B	1,25	Normally Open			6-30 V DC; 0,2 A		
P763976	Electrical	Differential	B	2,75	Normally Closed			6-30 V DC; 0,2 A		
P763975	Electrical	Differential	B	2,75	Normally Open			6-30 V DC; 0,2 A		
P167455	Electrical	Differential	B	2,75	Normally Closed			6-30 V DC; 0,2 A		
P165194	Electrical	Differential	B	2,75	Normally Open			6-30 V DC; 0,2 A		
P164745	Electrical	Differential	B	1,7	Normally Open			6-30 V DC; 0,2 A		
P171967	Electrical	Vacuum	C	-0,3	Normally Open	IP65	PG7 - DIN 46248	48 VAC - 30 VDC; 0,5 A res. and 0,2 A ind.		
P173105	Electrical	Vacuum	C	-0,3	Normally Closed	IP65	PG7 - DIN 46248	48 VAC - 30 VDC; 0,5 A res. and 0,2 A ind.		
P173104	Electrical	Pressure	C	1,2	Normally Closed	IP65	PG7 - DIN 46248	48 VAC - 30 VDC; 0,5 A res. and 0,2 A ind.		
P171966	Electrical	Pressure	C	1,2	Normally Open	IP65	PG7 - DIN 46248	48 VAC - 30 VDC; 0,5 A res. and 0,2 A ind.		
P764431	Electrical	Pressure	C	2,5	Normally Open	IP65	PG7 - DIN 46248	48 VAC - 30 VDC; 0,5 A res. and 0,2 A ind.		
P162696	Visual	Differential	D	1,7						
P167580	Visual	Differential	D	3,4						
P171950	Visual	Differential	E	1,4						
P171958	Visual	Pressure	F	1,2						
P764612	Visual	Pressure	F	2,5						
P171954	Visual	Vacuum	G	-1 till 3					3 color scale; connection central at back	
P171953	Visual	Vacuum	G	-1 till 5					3 color scale; connection at the side	

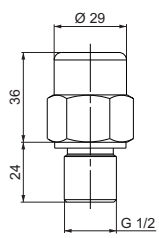
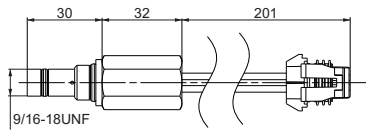
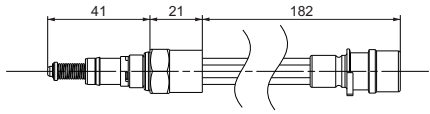
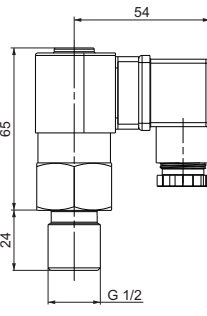
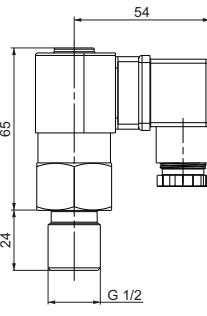
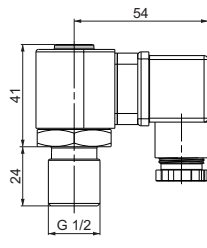
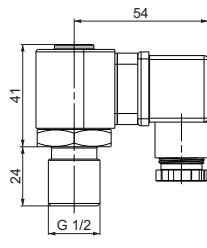
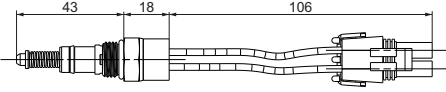
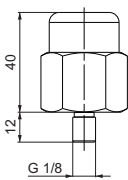
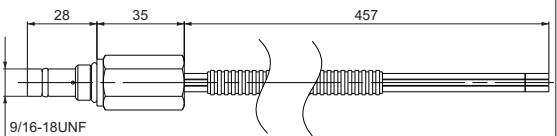
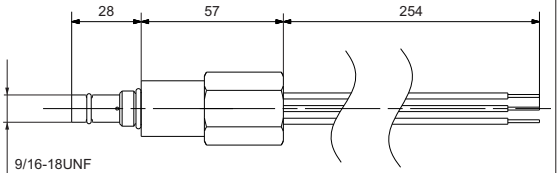
Part	Kind		Reference Drawing	Setting (bar)	Contact	Protection Class	Cable Clamp	Max. Values	Remark	
P761058	Visual	Differential	H	3						
P171945	Visual	Differential	H	5						
P170926	Electrical	Differential	I	2,75	Normally Closed		Packard Connector	6-30 V DC; 0,1 A		
P171143	Electrical	Differential	J	1,25	Normally Open		Cannon Connector	6-30 V DC; 0,2 A		
P171944	Electrical	Differential	K	5	Normally Open (3) / Closed (2)	IP65	PG11	250 VAC - 30 VDC; 5 A res. and ind.	with thermostat at min. temperature at 30°C	
P171947	Electrical	Differential	K	5	Normally Open (3) / Closed (2)	IP65	PG11	250 VAC - 30 VDC; 5 A res. and ind.		
P761057	Electrical	Differential	L	3	Normally Open (3) / Closed (2)	IP65	PG11	30 VAC - 30 VDC; 0,5 A res. and 0,2 A ind.		
P761056	Electrical	Differential	L	5	Normally Open (3) / Closed (2)	IP65	PG11	30 VAC - 30 VDC; 0,5 A res. and 0,2 A ind.		
P171087	Electrical	Differential	M	2,75	Normally Open		Packard Connector	6-30 V DC; 0,2 A		
P171959	Visual	Vacuum	N	-0,3						
P173893	Electrical	Differential	P	2,75	Normally Open (white) or Closed (red)	IP65	3 Wires	6-30 V DC; 0,1 A		
P173944	Electrical	Differential	Q	1,4	Normally Open (white) or Closed (red)	IP65	3 Wires	110V AC - 24V DC; 2 A		

Introduction

Donaldson introduces new product line.....	6
Overview.....	8
Technical References	13

Return Line Filters

Low Pressure Filters in-Tank

FIK-FIO.....	35
FIK-FIOT.....	43
FIK-FIS.....	51

Low Pressure Filters in-Line

FLK-FLS.....	57
FBK-FRCA.....	63

Return &/or Suction Line Filters

Low Pressure Filters in-Tank

FHK-FIR.....	69
SRK-COMBO.....	75

Suction Line Filters

Low Pressure Filters in-Tank

FIOA.....	83
-----------	----

Low Pressure Filters in-Line

FAL.....	89
FLK-FLA.....	93
FBK-FACA.....	99

Medium Pressure Filters In-Line

FMK-FM.....	105
FCK-LC.....	109
FLK.....	113
DURAMAX – HMK 04.....	119
DURAMAX – HMK 05.....	123

High Pressure Filters In-Line

FPK 02 – AP280.....	127
FPK 02 & 04 – AP220.....	133
FPK 03 & 04 – AP420.....	139
FCK-LC.....	145

Hydraulic Accessories

T.R.A.P.™ breathers.....	150
Hydraulic Cart for Off-Line Filtration.....	151
TCO.....	154
TCA.....	156
FS.....	157
FFCA.....	158
LVO/LVOT.....	159

Service Instructions..... 161

Conversion Tables 165

Product Part Index 187

Donaldson introduces new product line

FLK Medium Pressure Hydraulic Filtration

Engineered Filtration Power

Donaldson FLK filtration technology delivers all the latest hydraulic filtration advancements for Original Equipment Manufacturers in a single package. The FLK system, a reusable housing with disposable filter cartridge, can be configured with Donaldson's advanced Synteq XP™ media technology – or with other Donaldson media offerings – to satisfy a wide range of performance requirements.

Optimum Housing Design

FLK assemblies provide high pressure fatigue ratings. This robust, reusable housing and disposable cartridge design creates less waste than standard metal spin-on designs. The versatile FLK filter head also accommodates multiple filter lengths – reducing part numbers stocked while offering greater application coverage.

Cleaner, Easier Servicing

Industrial, raised hand grips make it easy to remove the housing from the head without the need for special servicing tools. The oil drain port on the bottom of the housing and the locking grab handles on the filter cartridge allow for cleaner servicing. The filter handles lock into place – simplifying positioning during reassembly. Short removal clearance is needed for filter replacement so the assembly can easily fit into tight spaces.

Our FLK hydraulic filtration systems are packed with innovative features that deliver cleaner, error proof filter servicing.

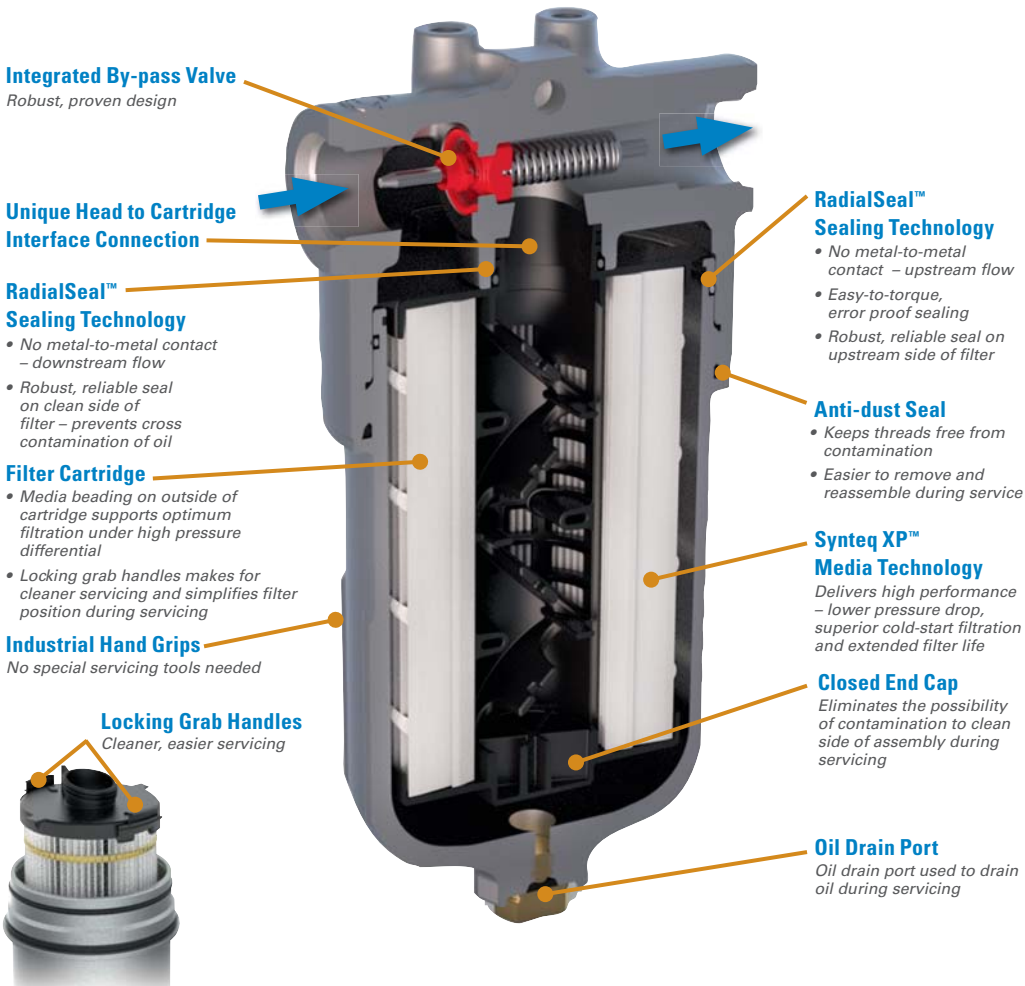

Environmental Care

Donaldson offers an optional metal-free, high-capacity cartridge that can be easily crushed or fully incinerated.





Industry Proven Sealing Technology

Enhanced Reliability

Donaldson pioneered RadialSeal™ sealing technology for air filtration more than 20 years ago. We've applied this proven design to hydraulic filtration in order to create a clean, leak-resistant seal – with no metal-to-metal contact for a new standard in system cleanliness.

This improved sealing technique protects systems from harmful ingressed contaminants and also prevents cross contamination of oil. By moving the threads outward, the RadialSeal interface increases the surface area which provides a robust connection with superior vibration resistance, a common challenge in today's heavy-duty applications.

RadialSeal™ Guarantees a Reliable, Sure-Fit

Robust seal on the clean side of filter is easy-to-torque and provides error-proof filter servicing. No metal-to-metal contact on both the downstream and upstream sides means no cross contamination of oil.

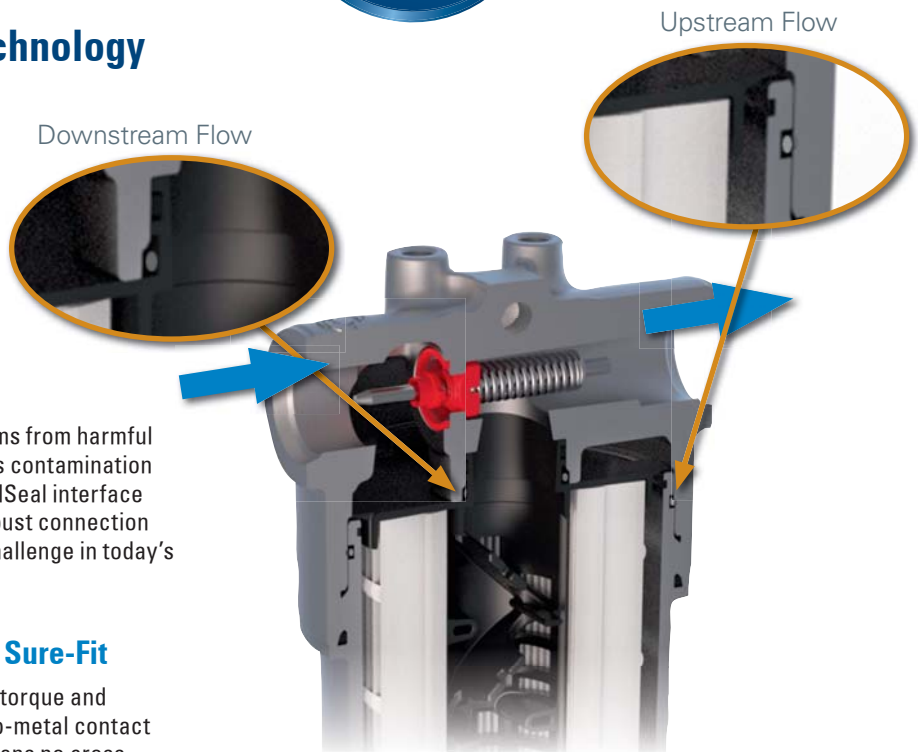

Industry Shaping Media Technology

Synteq XP™ Media Technology for Optimal Filtration Performance

Donaldson's breakthrough in synthetic filter media technology takes hydraulic filtration performance to a whole new level. This resin-free bonded media provides improved filtration to increase filter dirt holding capacity and reduce pressure drop, resulting in enhanced system performance and protection.

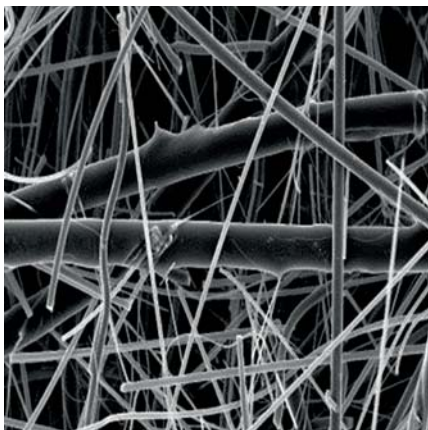

Synteq XP™ Media

Synteq XP is thermally bonded together to create small, consistent fibers – increasing the filter capacity. The pores remain unobstructed, resulting in reduced pressure drop and more surface area for capturing and retaining smaller particles.

Synteq XP Delivers:

- Lower operating pressure drop
- Higher efficiency for optimal hydraulic system protection
- Superior cold-start filtration
- Extended filter life (up to 2 to 3 times that of traditional media)

See brochure No. F111379. For more technical information, consult p. 113.

Hydraulic filtration solutions Engineered for today's industrial & mobile equipment



The best solutions for clean, dry oil.

Count on Donaldson to have the right filters, contamination control products and services to protect critical components in hundreds of applications – in the factory and on heavy-duty mobile equipment.

When you need hydraulic filtration, Donaldson delivers.

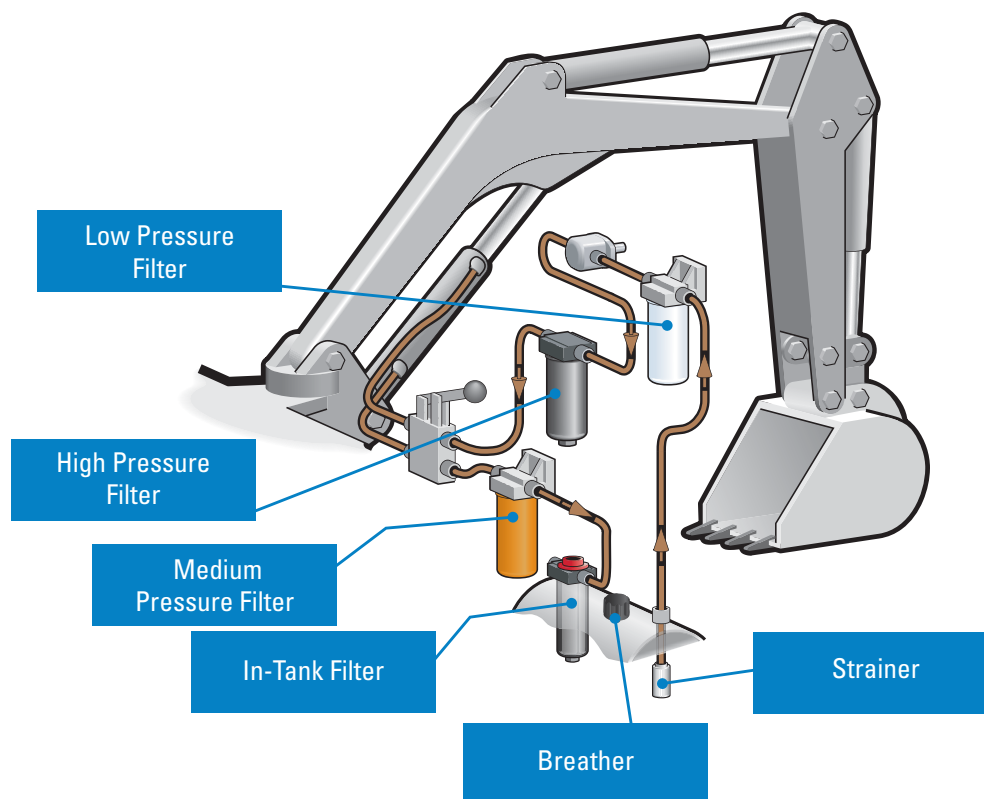

Full product range

The industry's largest selection of in-stock filters and accessories – manufactured with consistent, high-quality performance.

Expert technical support

Prompt, accessible and knowledgeable customer service experts.

High-performance filtration

Increase dirt-holding capacity and lower ΔP with Donaldson high-performance DT filters.

Hydraulic filtration solutions Engineered for today's industrial & mobile equipment



Performance under any pressure

- Low, medium and high pressure filtration
- Spin-on, cartridge and in-tank style filters

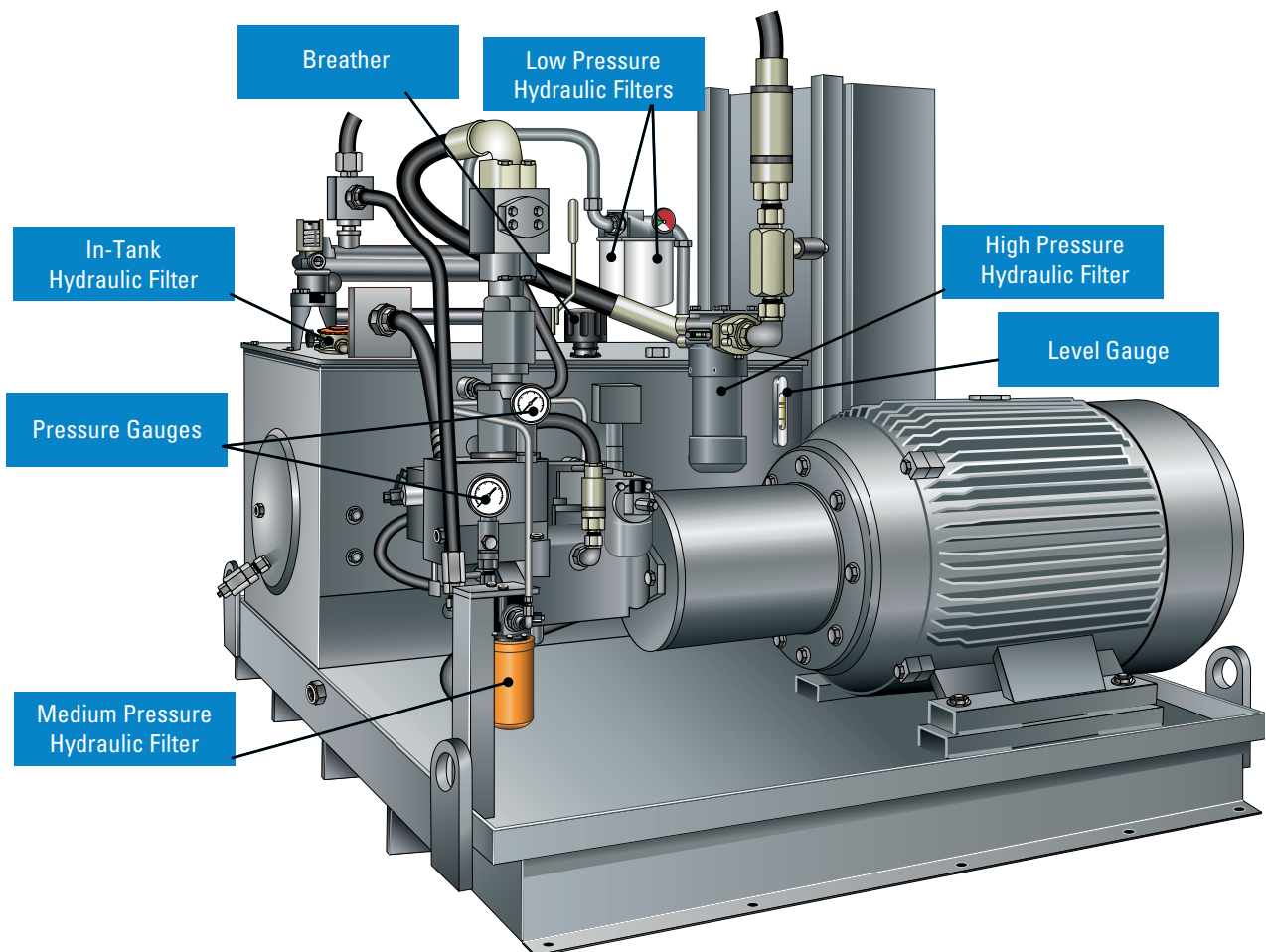

Off-line filtration

Filter carts, filter panels and Filter Buddy™ handheld filtration.

See Catalog No. F112100 ENG

Water removal

Systems and products designed to prevent water ingress and remove entrained water.

Vacuum dehydrators & coalescers

Quick removal of free water, dissolved water, particles and gases.

Industry shaping technology Global design & logistic capabilities



Donaldson has pioneered the use of a wide range of engineering, design and testing tools used during the product development and validation process.

Engineering capabilities

- Design centers in three key regions – Europe, United States and Asia

Prediction and simulation

- CAD
- Media modeling
- Fluid mechanics
- Structural analysis
- Thermal analysis

Development and validation

Filter durability

- Filtration performance testing per applicable SAE and ISO standards
- Fabrication integrity
- Environmental conditions
- Salt spray and thermal cycling
- Pressure fatigue
- Flow fatigue
- Hydrostatic burst
- Flow benches
- Vibration benches
- Gravimetric analysis

Rapid prototyping

- SLA, SLS
- Investment casting
- RTV molding

Test & evaluation tools

Structural Analysis

- Per SAE, ISO, and NFPA standards
- Burst
- Collapse
- Pressure impulse and fatigue

Tensile compression

- Used to test material, component and assembly properties

Environmental chambers

- Allows testing at hot or cold temperature, with humidity control

Flow test benches

- Allows measurement of static and dynamic flow and restriction for a device
- Allows calculation of device restriction at varying flows and temperatures
- System simulation

Filtration performance testing

- ISO, SAE, NFPA
- Customer standards
- Contaminant (particle or water) removal efficiency
- Contaminant capacity

Analytical chemistry laboratory

- Optical microscopy
- Scanning electron microscopy (SEM)
- Chemical analysis
- Fourier transform infrared (FTIR)
- Gas chromatography (GC/MS)
- Thermal analysis (DSC, TGA)
- Liquid chromatography

Industry shaping technology Global design & logistic capabilities

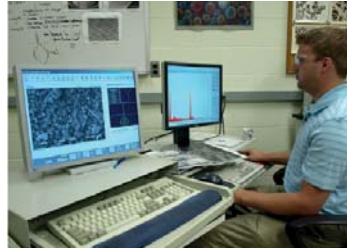

Design validation

- Test cell locations in three key regions – United States, Asia and Europe
- High viscosity ΔP
- High temperature
- Flow fatigue
- Used oil analysis
- Component durability
- 24/7 durability testing
- Web-based test cell monitoring access
- Fluid compatibility

Vibration/shaker

- Multiple benches
- Performance vibration with flow test
- Can apply random, shock or custom variable vibration profiles
- Capable of hot or cold tests

Field testing

- On and off highway
- Heavy-duty
- Tests conducted on both end user and OEM applications

Field data acquisition

- Real time measurements
- Remote communications
- On-line collection tools
- Review daily, weekly and monthly reports to analyze operational trends

Quality certified

- All facilities are ISO/TS certified

Quality controls

- Consistent, reliable product
- On-site verification test units and equipment
- Part number specific PLC controls
- Manufacturing dates for tracking and warranty

Manufacturing

Locations for liquid filtration

- Europe, United States, Canada, Mexico and Asia-Pacific
- Located strategically with global partners

Base component materials

- Built for long-life, durability, corrosion resistance and liquid compatibility
- Metal and non-metal materials
- Methods to enhance media durability include oven-curing, wire backing and multiple layered media

Packaging options

- Returnable packaging
- Heavy-duty packaging
- Pallets ISPM-15 compliant for international routing

Logistics / distribution

Donaldson has established a global distribution network to serve our customers locally and around the world. We operate as a global company with a network of primary distribution locations that support a mature hub of regional distribution centers and warehouses.

Donaldson distribution centers are strategically located around the globe to quickly and accurately deliver filtration and exhaust products wherever replacement products are needed. We work with a network of transportation, third party logistics companies, consolidators and cross-docking facilities to meet or exceed our customers' requirements.

Customers around the world benefit from our umbrella of distribution centers. We focus our efforts on local support and the capabilities of our staff. We continue to make significant investments in facilities, systems, supply chain relationships and staffing to offer the best order fulfillment options available.

Industry shaping technology Donaldson Italy capabilities

Leader in designing and manufacturing liquid filters

Donaldson Italia Srl was established in 1992, when DCI bought the existing Italian filter manufacturing company FBO, specialized in hydraulic filtration (industrial & mobile).

The company grew during the last 20 years, passing from 50 up to 210 employees. Over the years, Donaldson Italia Srl was and is able to develop new synthetic media, spin-ons and high pressure filters. This mainly thanks to the synergy with DCI and by supplying a huge number of OEM's. One of our main characteristics is the big flexibility and the capacity to develop customized products.

As all Donaldson factories, Donaldson Italia srl achieved the quality certification according to ISO 9001/2 and ISO 14000 as well as quality certification of our major OEM customers.



Donaldson Italia Srl in Ostiglia, Mantova (Italy)

Donaldson Italy Srl manufacturing means quality production

Most of the filter production process is automated, this enables us to build filters faster and with higher precision.

Daily plant production capacity (10.000m²):

- 4.000-8.000 Duramax hydraulic spin-ons
- 3.000-5.000 hydraulic cartridges
- 1.000 hydraulic filter assemblies
- 4.000 low pressure spin-on filters and liquid filters.

Recent investments in a new liquid lab and the engineering and sales office doubled the production facility.



Industry shaping technology Mix&Match – your flexible hydraulic solutions

History

Mix&Match is introduced to provide you more flexibility and a higher availability of hydraulic products.

You can create your own complete filter by selecting separately a housing, a cartridge and an indicator. The majority of these components will be stocked to provide you fast with the products you need.

The idea of Mix&Match

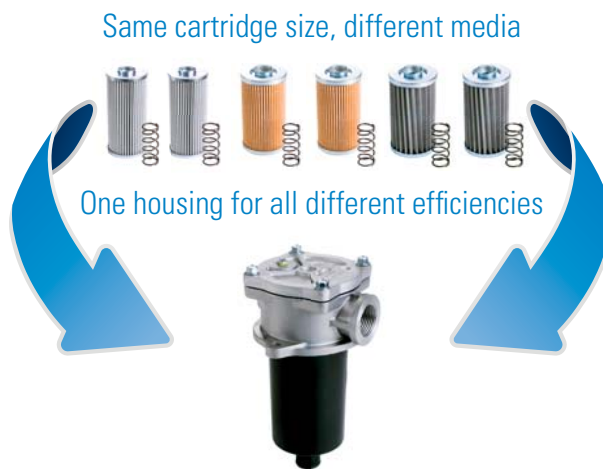

How to create your hydraulic product via the catalog?

The tables are composed in such a way that all components that fit together are on 1 row.

1. Pick the product series depending from the position in the hydraulic system, the working pressure and the required flow
2. Pick the required element based upon flow and efficiency
3. Follow this row to the right and the available (empty) housing is shown
4. Pick the indicator of your choice (make sure that it fits the predrilled hole).

Family	/9 90µm		/6 60µm		/3 β _{0.1µm} ≥1000		Standard Housing without Cartridge	CARTRIDGE DIMENSIONS				POSSIBLE INDICATOR			
	RMF		RMF		RMF			A	B	C	D		X	Y	Z
FIO20	20	P171500	20	P171505	15	P171504	P766446	G3/8	67	78	132	67	52	25.5	P171953 P171958 P171966 P173104
FIO30	30	P171500	30	P171505	20	P171504	P766447	G1/2	67	78	132	67	52	25.5	
FIO50	50	P171518	50	P171523	35	P171522	P766448	G1/2	90	100	172	75	70	29	

All cartridges are delivered with a sticker, with the Donaldson cartridge spare part number, that will mark the housing from the outside. All complete Mix&Match filters need to have this sticker attached to the outer housing.

Hydraulic Filter Locations Comprehensive Selection of Filtration Solutions

Typical Hydraulic Circuit and Filter Locations



Filter Symbol in a Circuit



Pressure Line Filter

Protects high-pressure side components. Helps prevent component wear or failure brought about by debris in the system.



In-Line Accessories

Pressure gauges for monitoring system pressure. Hoses and test points for sampling oil and determining ISO cleanliness levels. Flanges and valves for system control.



Suction Line Filter

Designed to remove particles in the 5 to 150 micron range. Easy to service and less expensive than other types of filters. Low bypass valve use recommended to prevent pump starvation.

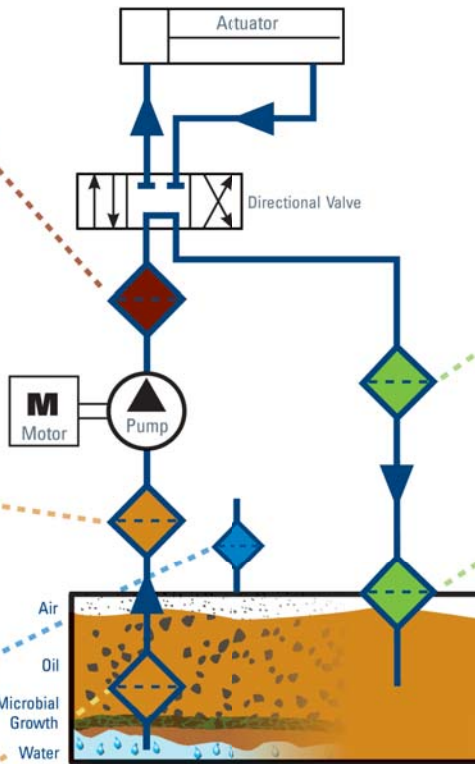

Return Line Filter

Captures debris from component wear or ingress before it travels into the reservoir.



In-tank Return Line Filter

Space-saving in-tank return and suction line filters.



Reservoir Air Breather

Prevents ingress of airborne contaminants from entering the reservoir tank.



Suction Strainer

Removes large particles or objects built into the system during assembly or introduced during standard maintenance. Prevents catastrophic failure.

Air
Oil
Microbial Growth
Water

Reservoir Tank

Water in reservoir tanks is a serious threat to hydraulic systems. Dirt, particles and microbial growth are also common contaminants existing in tanks.



Reservoir Accessories

Sight and level gauges available. Diffusers are used for effectively reducing aeration, foaming, turbulence and noise caused by return lines.



Kidney Loop Filters

Off-line filtration supplements system cleanliness. Use with industrial and mobile equipment to achieve and maintain proper ISO cleanliness levels.

Donaldson provides this technical reference as a short course in “Hydraulic Filtration” – for those who want to gain a better understanding of hydraulic filtration.

In industrial and mobile applications at factories all over the world, we too often see hydraulic circuits that don’t include proper fluid filtration, or include it as an afterthought. Good filtration needs to be an integral part of the hydraulic circuit to ensure the long life and proper operation of the pumps, valves and motors.

A €100 filter protects your €100,000 equipment.

This section is offered to aid in choosing the filter that will help you achieve the ideal cleanliness levels and longest life for your critical components.

Topics

Hydraulic Components Need Protection	14
How Contamination Damages Precision Parts	14
Types of Contaminant	14
Typical Factors in Component Life	14
Where Contamination Comes From	15
Fluid Conditioning	16
Proper Filter Application	17
Fluid Properties	17
Types of Hydraulic Fluid	18
How Filter Media Functions in a Filtration System	19
How Filter Media Collects Particles	19
Basic Types of Hydraulic Filter Media	20
Donaldson Filter Media Efficiency Ratings per ISO 16889 Test Standards	22
Hydraulic Filtration Pressure Drop	23
Four Major Factors Contribute to Pressure Drop	23
Viscosity/Temperature Chart	24
Filter Design and Construction	25
Combining the ISO Rating and Filter Performance Ratings	26
Filter Efficiency Standards	28
Donaldson Hydraulic Filter Media Beta Ratings	30
Cleanliness Level Correlation Table	31
Compatibility of Donaldson Filter Media with Hydraulic Fluids	32
Threads	32

Symbols Used

β	Beta Ratio
cSt	Centistokes
DP	Pressure Drop or Differential Pressure
ISO	International Standards Organization
μm	Micron or micrometer
ppm	Parts per million
SSU	Saybolt Seconds Universal

Material in this section is in the public domain, not confidential, and may be copied for educational purposes at any time. Information was collected from many sources, both public and private, including Donaldson Company, Inc. Engineering Departments, Eaton Corporation, the Lightning® Reference Handbook from Berendsen Fluid Power, Hydraulics & Pneumatics Magazine, National Fluid Power Association (NFPA), and various industry authorities.

Hydraulic Components Need Protection

Fluid power circuits are designed in all shapes and sizes, both simple and complex in design, and they all need protection from damaging contamination. Abrasive particles enter the system and, if unfiltered, damage sensitive components like pumps, valves and motors. It is the job of the hydraulic filter to remove these particles from the oil flow to help prevent premature component wear and system failure. As the sophistication of hydraulic systems increases, the need for reliable filtration protection becomes ever more critical.

How Contamination Damages Precision Parts

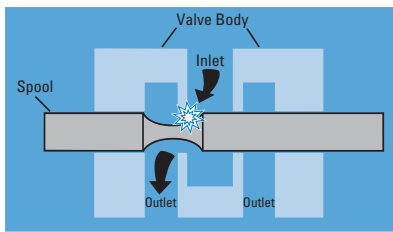

This illustration of a simple hydraulic valve illustrates how particles damage components. In normal operation,

the spool slides back and forth in the valve body, diverting oil to one side of the valve or the other. If a particle lodges between the spool and valve body, it will erode small wear particles from the metal surfaces. As these wear particles are moved back and forth by the action of the spool, they can roll into a burr that jams the spool and disables the valve.



Component Damage

Looking down the barrel of an hydraulic cylinder, we can see the scratches along the inside surface. Don't cut costs by eliminating hydraulic filters. It could cost you more in the long run in major component repairs.

Types of Contaminant

- Many different types of contamination may be present in hydraulic fluid, causing various problems. Some are:
- Particulate (dust, dirt, sand, rust, fibers, elastomers, paint chips)
- Wear metals, silicon, and excessive additives (aluminum, chromium copper, iron, lead, tin, silicon, sodium, zinc, barium, phosphorous)
- Water
- Sealants (Teflon®* tape, pastes)
- Sludge, oxidation, and other corrosion products
- Acids and other chemicals
- Biological, microbes (in high water based fluids)

* Teflon is a registered trademark of E. I. DuPont de Nemours & Co., Inc.

Typical Factors in Component Life

Studies show that most (typically 70%) of hydraulic component replacement is necessary because of surface degradation, and most of that is due to mechanical wear. Proper filtration of hydraulic fluids can lengthen component life.

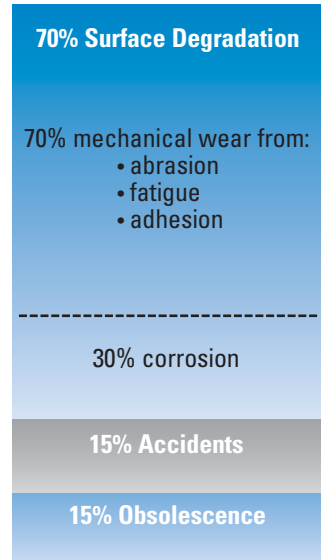

Disaster Strikes

When filters are not a main component of the hydraulic circuit, disaster awaits. Here, piston rings were eaten away by contaminants.

Where Contamination Comes From

There are a surprising number of contaminated sources in a hydraulic system or circuit.

New Hydraulic Fluid

Adding new fluid can be a source; even though it's fresh from the drum, new hydraulic fluid isn't clean. (It may look clean, but, remember, the human eye can only see a particle the size of about 40 μm .) Oil out of shipping containers is usually contaminated to a level above what is acceptable for most hydraulic systems: typically, new fluid has a cleanliness level about the same as ISO Code 23/21/19, and water content is typically 200 to 300 ppm. Never assume your oil is clean until it has been filtered. One very effective way of ensuring thorough fluid conditioning is with a dedicated off-line circulation loop, or "kidney" loop filtration.

Built-In

Built-in contamination, also called primary contamination, is caused during the manufacture, assembly and testing of hydraulic components. Metal filings, small burrs, pieces of Teflon tape, sand and other contaminants are routinely found in initial clean up filtration of newly manufactured systems.

Ingressed

Ingressed or external contamination comes from the environment surrounding the system. Dirt can enter the hydraulic fluid supply through leaking seals, reservoir breather caps, and worn cylinder rod seals. Ingressed moisture, particularly, can cause long-term problems. As a hot system cools at night, cool moisture-laden air can be drawn into the reservoir; as the air condenses, water is released into the reservoir. Water in excess of 0.5% by volume in a hydrocarbon-based fluid accelerates the formation of acids, sludge and oxidation that can attack internal components, cause rust, and adversely affect lubrication properties. The severity of ingress and type of contaminant are dictated by the applications and environment.

Induced

Maintenance procedures can introduce contamination into the system. Opening the system allows airborne particles to enter. Leaving the system open during operation provides continuous ambient particle ingress. Keep your system closed as much as possible.

In-Operation

The major source of contamination are the pump and actuators, the hydraulic cylinder, or the hydraulic motor. Wear-generated contaminants are a hazard during normal hydraulic system operation. The circuit actually generates additional particles as the fluid comes into contact with the precision machined surfaces of valves, motors and pumps. Contaminant levels can keep doubling with every new particle generated. The result can be catastrophic if these contaminants are not properly filtered out of the system.

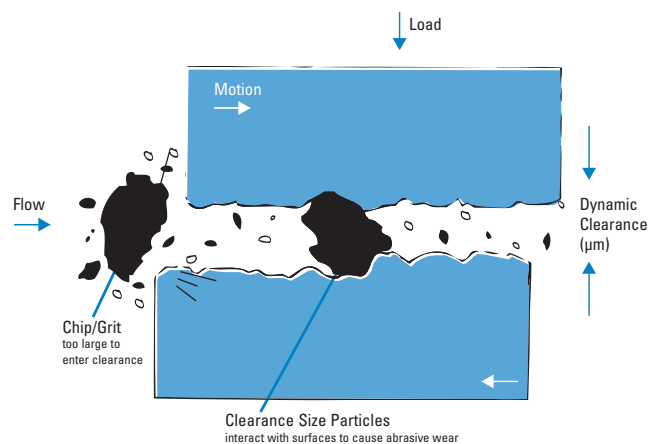

Rubber & Elastomers

Due to temperature, time, and high-velocity fluid streams, rubber compounds and elastomers degrade – thus releasing particulates into the fluid. This may be from hoses, accumulator bladders, seals, or other elastomer products.

High Water Based Fluids

The water in HWBF tends to support biological growth and generate organic contamination and microbes.

Replacement of Failed Components

Failure to thoroughly clean fluid conductor lines after replacing a failed hydraulic pump will cause premature catastrophic failure.

Donaldson recommends frequent oil sampling to ensure proper contamination control. Sample test points should be close to hydraulic pumps and at other key locations that provide safe, reliable access to the fluid while under full system pressure.

Fluid Conditioning

Fluid Conditioning is the term for the overall conditioning of the fluid in the hydraulic system, and encompasses particulate removal via filters along with other various methods for removing silt, air, water, heat, acid, sludge or chemicals.

Particulate Removal

Particulate removal is usually done with mechanical filters. A well designed reservoir that allows settling will also help in keeping particulates out of the mainstream fluid. For ferrous particulates and rust, reservoir magnets or strainer band magnets can also be used. Other methods such as centrifuging or electrostatic filtration units can also be used, particularly in continuous batch processing and fluid reclamation.

Removal of Silt

Silt, defined as very fine particulate under 5 µm in size, requires very fine filtration or “oil polishing.”

Air Removal

Getting air out of the system is best done by adding 100 mesh screen in the reservoir, approximately 30° from horizontal to coalesce entrained air and allow larger bubbles to rise to the surface when reservoir velocities are low.

Water Removal

A number of techniques exist to prevent water or moisture ingress or to remove water once it is present in a hydraulic or lube oil system. The best choice of technique for removal is dependent on the whether or not the water exists as a separate phase (dissolved or free), and also on the quantity of water present. For example, the presence of water or moisture can be reduced or prevented from entering a fluid reservoir through the use of absorptive breathers or active venting systems. However once free water is present in small quantities, water absorbing

filters or active venting systems usually provide adequate removal means. For large quantities of water, vacuum dehydration, coalescence, and centrifuges are appropriate techniques for its removal. However, as each of these techniques operates on different principles, they have various levels of water removal effectiveness. The chart below provides comparative information on these techniques and their relative effectiveness. Care should be taken to apply the best technique to a given situation and its demands for water removal.

Chemical Removal

Removal of acids, sludge, gums, varnishes, soaps, oxidation products and other chemicals generally requires an adsorbent (active) filter with Fuller Earth, active type clays, charcoal, or activated alumina.

Heat Removal

Removing heat is important to maintain viscosity and prevent fluid breakdown. Usually performed with heat exchangers, including air-to-oil and water-to-oil types, finned coolers, or refrigerated units.

Heat Addition

Added heat is used for cold temp start-up to get fluid viscosities within operational limits. Use heaters, immersion or in-line.

Kidney Loop Filtration

One very effective way of ensuring thorough fluid conditioning is with a dedicated off-line circulation loop, or “kidney” loop. This system uses a separate circulation pump that runs continuously, circulating and conditioning the fluid. Multiple stages and types of filters can be included in the circuit, as well as heat exchangers and in-line immersion heaters.

Water Prevention and Removal Techniques

	Usage	Prevents Humidity Ingression	Removes Dissolved Water	Removes Free Water	Removes Large Quantities of Free Water	Limit of Water Removal
Adsorptive Passive Breather	prevention	Y				n/a
Active Venting System	prevention and removal	Y	Y	Y		down to <10% saturation
Water Absorbing Cartridge Filter	removal			Y		only to 100% saturation
Centrifuge	removal			Y	Y	only to 100% saturation
Coalescer	removal			Y	Y	only to 100% saturation
Vacuum Dehydrator	removal		Y	Y	Y	down to ~20% saturation

Proper Filter Application

When selecting a new filter assembly or replacement filter, it's important to first answer some basic questions about your application. Where will the filter be used? What is the required cleanliness level (ISO code) of your system? What type of oil are you filtering? Are there specific problems that needed to be addressed?

It's also important to think about the viscosity of the fluid in your system. In some machinery lubrication applications, for example, the oil is very thick and has a tougher time passing through the layer of media fibers. Heating techniques and the addition of polymers can make the liquid less viscous and therefore easier to filter. Another option is to install a filter with larger media surface area, such as the Donaldson W041 or HRK10 low pressure filters, that can accommodate more viscous fluids. (see Catalog No. F112100)

Next, think about duty cycle and flow issues. Working components such as cylinders often create wide variations in flow – also called pulsating flow – that can be problematic for filters with higher efficiency ratings. On the other hand, dedicated off-line filtration (also called “kidney loop”) produces a very consistent flow, so it makes sense to use a more efficient filter.

Filters used in applications with steady, continuous operation at lower pressures will last longer than filters that must endure cycles of high pressure pulsating flow. Generally, the lower the micron rating of a filter, the more often it needs to be changed since it is trapping more particles.

Finally, it's wise to ask yourself, “How much is my equipment worth?” Calculate how much it would cost to replace the equipment in your system, in case of component failure, and make sure those areas are well protected with proper filtration. (For example, high performance servo valves are very sensitive, costly components that need to be protected with finer filtration media.)

Minimizing maintenance costs through good contamination control practices requires proper filter application based on the specific contamination problems. Good contamination control means cost-effective filtration. When looking for a filter, first assess the needs of your system and any problem areas.

Characteristics to Consider When Specifying a Filtration System

1. Oil Viscosity
2. Flow
3. Pressure
4. What Components will be protected by the filter
5. Cleanliness level required (expressed in ISO code)
6. Type of oil/fluid
7. Environment (the system, the surrounding conditions, etc.)
8. Duty cycle
9. Operating Temperature

Fluid Properties

Lubricity The property of the fluid that keeps friction low and maintains an adequate film between moving parts.

Viscosity The thickness of the fluid as measured by resistance to flow. The fluid must be thin enough to flow freely, heavy enough to prevent wear and leakage. Hydraulic fluids thicken when they cool and thin out as they heat up. Because some hydraulic systems work under wide temperature extremes, viscosity can be an important factor.

Viscosity Index (VI) The rate of viscosity change with temperature: the higher the index, the more stable the viscosity as temperature varies. VI can sometimes be improved by additives, usually polymers.

Rust Resistance Rust inhibiting chemicals in hydraulic fluids help overcome the effects of moisture from condensation.

Oxidation Resistance Oxidation inhibitors delay the sludgy/acidic effects of air, heat, and contamination in the system.

Foaming Resistance Although control of foaming depends largely on reservoir design, anti-foaming additives in the fluid also help.

Types of Hydraulic Fluid

There are many kinds of fluids used for power, but they can basically be called petroleum-based fluids, biodegradable fluids, and fire-resistant fluids. A brief description of some of the types in each category are listed below; for details on these or others, consult your filter supplier or refer to a reputable manual on hydraulics, such as the Lightning Reference Handbook, published by Berendsen Fluid Power, Whittier, CA 90601.

Petroleum Based (Hydrocarbon)

These are the most commonly used fluids in hydraulic systems. Their major advantages are low cost, good lubricity, relatively low/non-toxicity, and common availability. This type of fluid is not just plain oil; rather, it is a special formulation with additives that make it suitable for hydraulic systems. Mostly, the additives inhibit or prevent rust, oxidation, foam and wear.

Variations:

- Straight oils: same as petroleum-based oil but without the additives.
- Automatic transmission fluids (ATF): excellent low temp viscosity and very high VI.
- Military hydraulic fluids (ie: MIL-H-5606 and MIL-H-83282): also called 'red oil' because of the color. Low viscosity, good for cold temp operations, but may have to be modified for pumps.

Fire Resistant Fluids

There are two types of fire-resistant fluids commonly used in hydraulic applications: Phosphate Esters and High Water Based Fluids (HWBF). Although generally not as viscous at cold temperatures as petroleum-based fluids, they are fire resistant due to their high content of noncombustible material. Very useful in overcoming the likelihood of fire caused by a broken hydraulic line spraying petroleum fluid into a pit of molten metal, onto a hot manifold, into a heat-treating furnace, or other ignition source.

Some types of HWBF:

- Oil-in-water emulsions (HFA): typically 95% water and 5% oil, with the oil droplets dispersed throughout the water. Provide some fire resistance, but due to oil content, other fluids are superior.
- Water-in-oil emulsions (invert emulsion HFB): typically 40% water and 60% oil, with the water dispersed in the oil. Provide some fire resistance, but due to oil content, other fluids are superior.
- Water-glycol (HFC): typically 40% water and 60% glycol. Excellent fire resistance. Since glycol is an antifreeze, water-glycol can be used at lower temps.

NOTE: HWBF may require reduced pressure rating of pumps and other components.

HFD Fluids

The HFD group is a classification given to several different types of synthetic products that do not contain petroleum oil or water. Phosphate ester fluids were the first HFD fluids and are the most fire resistant within the HFD family. Not as popular today, their use declined due to poor environmental performance, limited compatibility, and high cost.

Certain phosphate esters have very high auto-ignition temperatures and are still used in specific applications, such as aircraft and power generation.

A common brand is known as Skydrol® (registered trademark of Solution, Inc.). Skydrol requires EPR seal for chemical compatibility. Today most phosphate esters have been replaced by polyol esters. Based on organic esters, polyol esters are the most common HFD fluids used today. They offer good inherent fire resistance, good compatibility with system materials, excellent hydraulic fluid performance, and easy conversion from petroleum oil. In addition, the organic nature of these fluids gives them good environmental performance in biodegradability and aquatic toxicity. Another type of synthetic, fire resistant fluids have been formulated for certain niche markets.

Water free polyalkylene glycols (PAGs) feature extended fluid life and good environmental performance. Technically an HFD fluid, PAGs (also known as polyalphaolefins (PAOs)) are more often used for their biodegradability and overall environmental friendliness. This group also contains the synthetic silicone (siloxane) oils, known for their anti-foaming properties.

Biodegradable

With increasing concern about the environmental impact of hydraulic system leaks and spills, biodegradable fluids are receiving expanded usage, particularly in Europe. There are two types of common biodegradable hydraulic fluids:

1) vegetable-based oils, such as sunflower or rapeseed oils, and 2) synthetic oils like diesters, etc. Generally, systems using biodegradable fluids are derated for maximum and minimum temperatures. Users who replace standard hydraulic oils with biodegradable oils must check with filtration component manufacturers to confirm that the fluid and components are compatible.

How Filter Media Functions in a Filtration System

The job of the media is to capture particles and allow the fluid to flow through. For fluid to pass through, the media must have holes or channels to direct the fluid flow and allow it to pass. That's why filter media is a porous mat of fibers that alters the fluid flow stream by causing fluid to twist, turn and accelerate during passage.

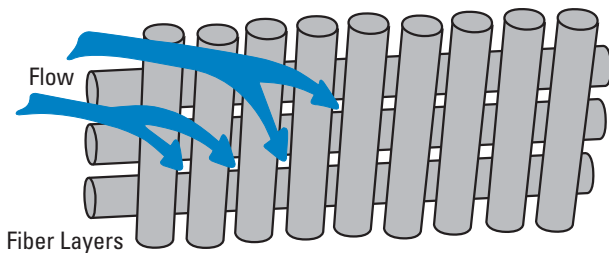

The fluid changes direction as it comes into contact with the media fibers, as illustrated above. As the fluid flows through the media, it changes direction continuously as it works its way through the maze of media fibers. As it works its way through the depths of the layers of fibers, the fluid becomes cleaner and cleaner. Generally, the thicker the media, the greater the dirt-holding capacity it has.

Looking at a cross-section view of the fibers, we can see how the flowstream is accelerated as it flows into the spaces between the fibers.

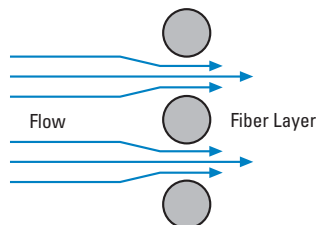

How Filter Media Collects Particles

There are four basic ways media captures particles

The first, called **inertia**, works on large, heavy particles suspended in the flow stream. These particles are heavier than the fluid surrounding them. As the fluid changes direction to enter the fiber space, the particle continues in a straight line and collides with the media fibers where it is trapped and held.

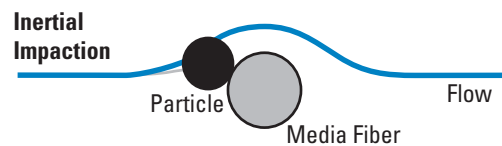

The second way media can capture particles is by **diffusion**. Diffusion works on the smallest particles. Small particles are not held in place by the viscous fluid and diffuse within the flow stream. As the particles traverse the flow stream, they collide with the fiber and are collected.

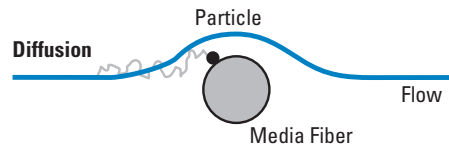

The third method of particle entrapment is called **interception**. Direct interception works on particles in the mid-range size that are not quite large enough to have inertia and not small enough to diffuse within the flow stream. These mid-sized particles follow the flow stream as it bends through the fiber spaces. Particles are

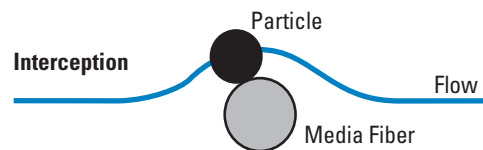

intercepted or captured when they touch a fiber.

The fourth method of capture is called **sieving** and is the most common mechanism in hydraulic filtration. As shown at right, this is when the particle is too large to fit between the fiber spaces.

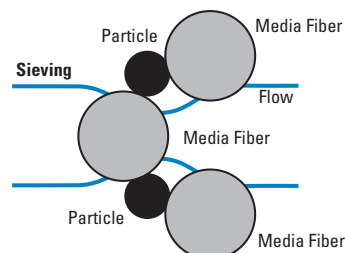

Basic Types of Hydraulic Filter Media

Filter Media

Media is a term used to describe any material used to filter particles out of a fluid flow stream. There are four basic types used to remove contamination in hydraulic applications:

Cellulose Media (Traditional)

Cellulose fibers are actually wood fibers, microscopic in size and held together by resin. Fibers are irregular in both shape and size. Cellulose often has lower beta ratings, which means there are smaller pores in the media. Smaller media pores cause more flow resistance, resulting in higher pressure drop.

While cellulose provides effective filtration for a wide variety of petroleum-based fluids, in certain applications it results in poor filtration performance as compared to synthetic media.

SEM 100X

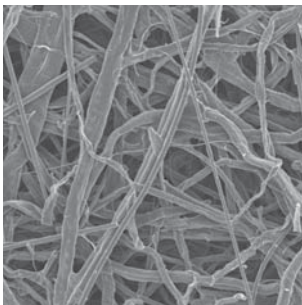

SEM 600X

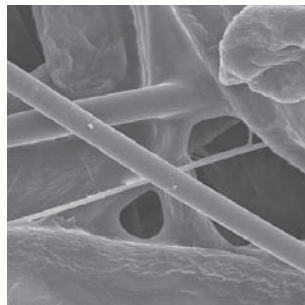

MEDIA IMAGE



HOW IT WORKS

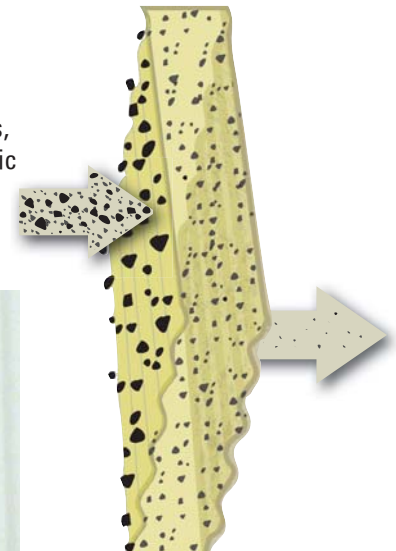

Synteq™ Media (Full Synthetic)

Synthetic fibers are man-made, smooth, rounded and provide the least resistance to flow. Their consistent shape allows for control of the fiber size and distribution pattern throughout the media mat to create the smoothest, least inhibited fluid flow. Consistency of fiber shape allows the maximum amount of contaminant-catching surface area and specific pore size control. The result is media with predictable filtration efficiencies removing specified contaminants and maximum dirt holding capacity.

The low resistance of synthetic media to fluid flow makes it ideal for use with synthetic fluids, water glycols, water/oil emulsions, HWCF and petroleum-based fluids.



HOW IT WORKS

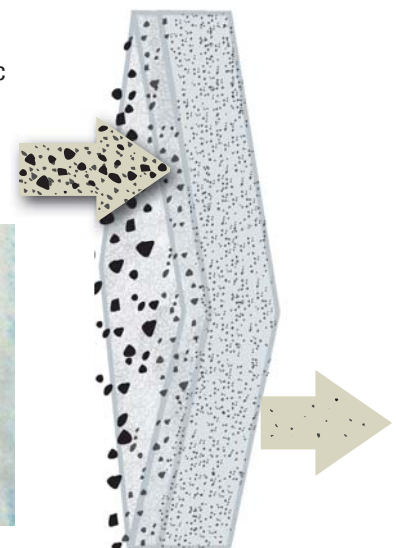

SEM 100X

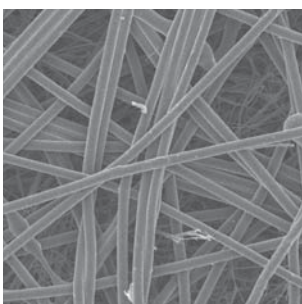

SEM 600X

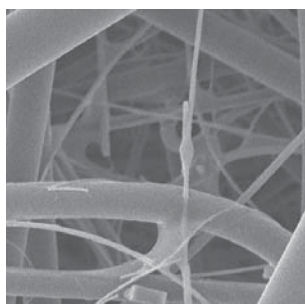

MEDIA IMAGE



Wire-Mesh Media

Wire-mesh media consists of stainless steel, epoxy-coated wire mesh available in 3 mesh sizes:

- 100 mesh yields 150 µm filtration
- 200 mesh yields 74 µm filtration
- 325 mesh yields 44 µm filtration

Typically wire-mesh filters will be applied to catch very large, harsh particulate that would rip up a normal filter. You may also find this media useful as a coarse filter in viscous fluid applications.

SEM 60X

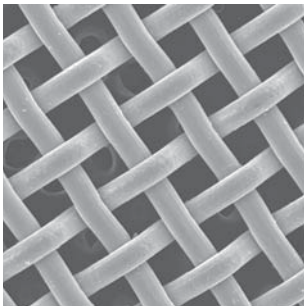

SEM 100X

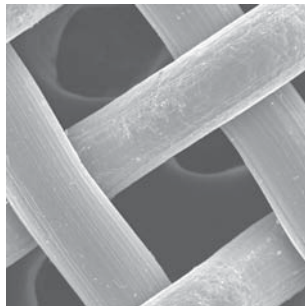

MEDIA IMAGE

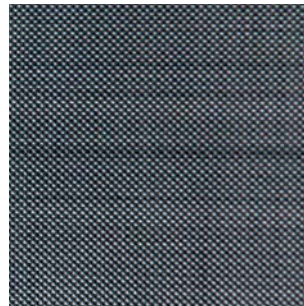

HOW IT WORKS

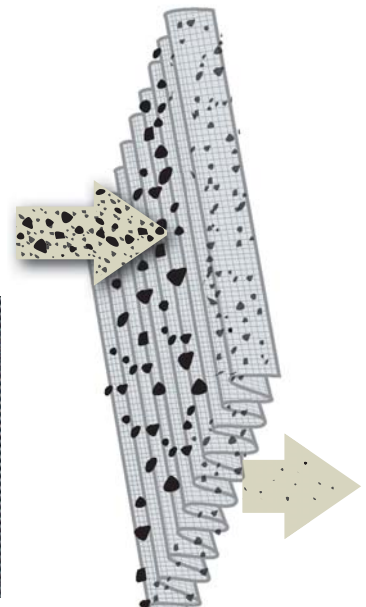

Water Absorbing Media

Water absorption media quickly and effectively removes free water from hydraulic systems. Using super-absorbent polymer technology with a high affinity for water absorption, this media alleviates many of the problems associated with water contamination found in petroleum-based fluids.

SEM 100X

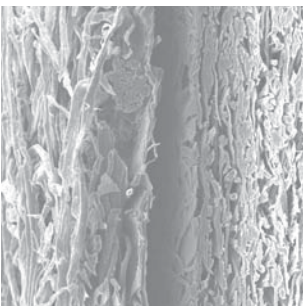

SEM 600X

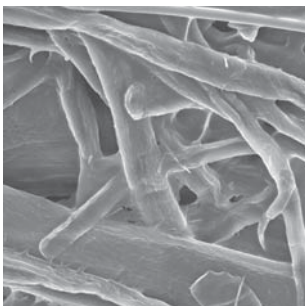

MEDIA IMAGE



HOW IT WORKS

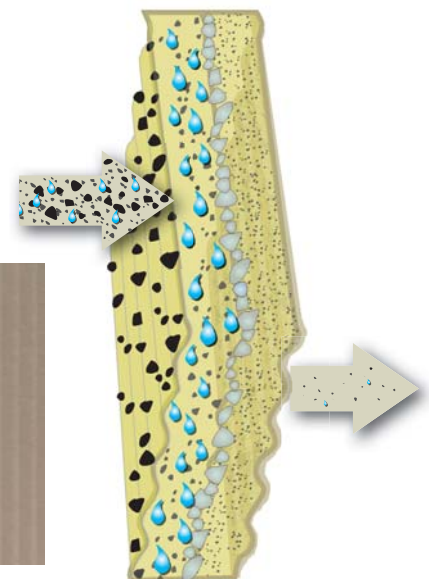

Hydraulic Filtration Pressure Drop

The difference between the inlet pressure and the outlet pressure is called pressure drop or differential pressure. It's symbolized by ΔP . ΔP is an irrecoverable loss of total pressure caused by the filter, and is mostly due to frictional drag on the fibers in the media.

Differential drop drop may increase as the particulate rating or efficiency of the filter (as expressed by its beta ratio) gets better. ΔP also increases as the filter is being loaded with contaminant.

Four Major Factors Contribute to Pressure Drop

1. Filter Media

Media is, of course, the main factor influencing pressure drop; indeed, it causes pressure drop. That's why having a low-friction, high-flowing media is so important. The natural cellulose or paper fibers (shown at left) typically used in filtration are large, rough, and as irregular as nature made them.

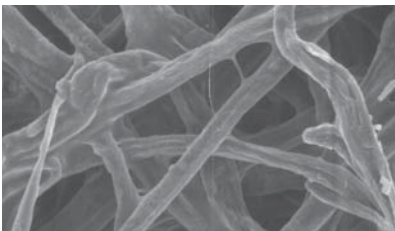

Natural Fiber Cellulose media, as seen under the scanning electron microscope.

Donaldson developed a synthetic media with smooth, rounded fibers, consistently shaped so that we can control the fiber size and distribution pattern throughout the media mat, and still allow the smoothest, least inhibited fluid flow. Our synthetic media is named Synteq™.

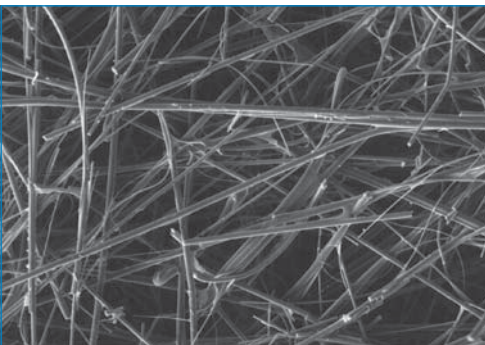

Donaldson's synthetic Synteq filter media — photo from scanning electron microscope — magnified hundreds of times.

Synteq fibers offer the least amount of resistance to fluid passing through the media. Consistency of fiber shape allows the maximum amount of contaminant-catching surface area and specific pore size control. The result is media with predictable filtration efficiencies at removing specified contaminants (i.g., 4 μm) and maximum dirt holding capacity.

Natural cellulose fibers are larger than synthetic fibers and jagged in shape, so controlling size of the pores in the media mat is difficult and there is less open volume. In most applications this results in higher ΔP as compared to synthetic filters. Higher beta ratings mean there are smaller pores in the media; smaller media pores cause more flow resistance, in turn causing higher pressure drop.

2. Dirt, Contaminant

As dirt gets caught in the media, it eventually begins to build up and fill the pore openings. As the pore openings shrink, the differential pressure (pressure drop) increases. This is called restriction. This photo from our scanning electron microscope shows actual dirt particles building up in the media pores.

Excessive dirt in the media can cause dirt migration or even filter failure. Dirt migration occurs when the restriction is so great that the differential pressure pushes dirt deeper into the media and, eventually, through the media and back into the system. Filter failure occurs when the restriction becomes so high that the filter cartridge collapses (outside-in flow) or bursts (inside-out flow) to relieve the upstream pressure.

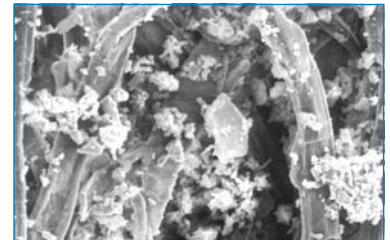

To avoid such catastrophe, use of a filter service indicator is recommended. It measures the pressure drop across the filter, then signals when the filter is 'full' and needs to be changed.

3. Flow

Higher flows create higher pressure drop. With fast moving fluid, there will be more friction causing higher pressure drop across the media.

4. Fluid Viscosity

Measured in centistokes (cSt) or Saybolt Seconds Universal (SSU or SUS), fluid viscosity is the resistance of a fluid to flow. As fluid viscosity increases, the cSt rating increases. Higher fluid viscosities also mean higher pressure drop because the thicker oil has a tougher time passing through the layer of media fibers. Cold start fluid is a good example of highly viscous fluid. See chart below.

Filter media, amount of contamination, the flow rate, and fluid viscosity are all factors in the importance of sizing the filter for the system requirements. Filters that are too small won't be able to handle the system flow rate and will create excessive pressure drop from the start. The results could be filter operation in the bypass mode, filter failure, component malfunction, or catastrophic system failures. Filters that are too large for the system can be too costly. Oversized filters require more system oil and higher cost replacement filters. Optimal sizing is best.

Viscosity/Temperature Chart

A.S.T.M. Standard Viscosity-Temperature Chart for Liquid Petroleum Products (D 341-43) Saybolt Universal Viscosity

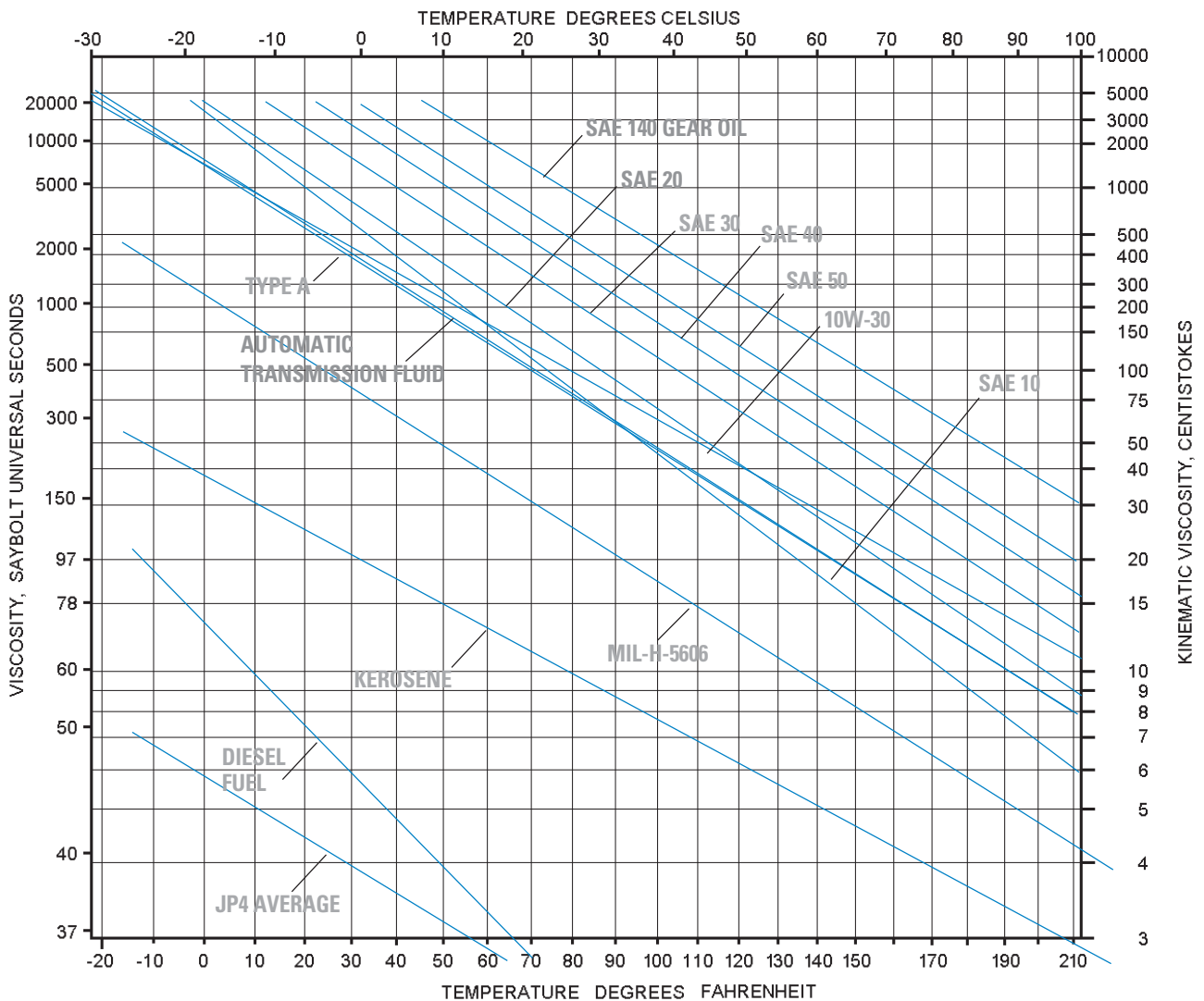

How Donaldson Displays Filter Flow versus Pressure Loss Data

Pressure Drop (ΔP) Correction Formulae

To properly calculate pressure loss for viscosity and/or specific gravity, use the filter and housing formulae below to determine the clean filter assembly pressure drop.

Filter Correction Calculation

$$\Delta P \text{ Filter} = \Delta P \text{ from graph} \times \frac{\text{New Saybolt Seconds Universal Viscosity (SSU)}}{150} \times \frac{\text{New Specific Gravity (S.G.)}}{.90}$$

- or -

$$\Delta P \text{ Filter} = \Delta P \text{ from graph} \times \frac{\text{New Centistokes Viscosity (cSt)}}{32} \times \frac{\text{New Specific Gravity (S.G.)}}{.90}$$

Clean Filter Assembly Pressure Drop (ΔP) Calculation

$$\Delta P \text{ Clean Filter Assembly} = \Delta P \text{ head} + \Delta P \text{ filter}$$

Filter, Head or Housing/Assembly Reference

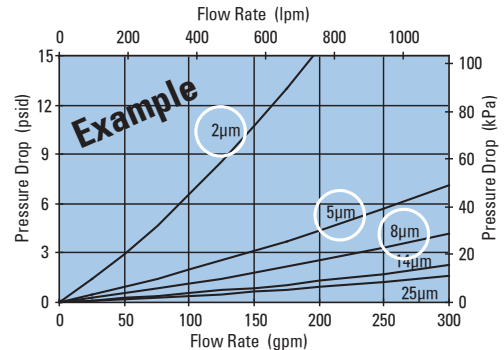

Performance Curve Notes

- All flow measurements were made with 32cSt [150 SSU] hydraulic oil at 100°F (37.7°C), fluid specific gravity of 0.9.
- The performance curves displayed are for the filter, head or housing assembly.
- Filter performance curves will either list media numbers or beta ratings (see circled areas on chart above). These labels correspond with the filter choice tables.

The Importance of Temperature in Determining Pressure Drop

Fluid viscosity plays an important role in restricting the flow through filters. It's crucial to select the proper filter to maintain adequate flow and avoid excessive pressure drops. Measured in centiStokes (cSt) or Saybolt Seconds Universal (SSU or SUS), fluid viscosity is the resistance of a fluid to flow (thickness of fluid). Low viscosity fluids pass through filters with less resistance than high viscosity fluids. Higher fluid viscosities have higher pressure drops due to higher resistance passing through the media. The colder the fluid, the higher the viscosity, so the lowest potential temperature of the fluid is the best measure for calculating pressure drop.

Use the chart below to determine the viscosity of the fluid to be filtered at its lowest potential temperature.

Oil Kinematic Viscosity Combined With Temperature in centiStokes (cSt)

SAE Gear Oil		75W			80W		85W	90W		140W		
Hydraulic Oil ISO Grade		15	22	32	46	68	100	150	220	320	460	680
°F	°C											
248°	120°			3.7	3.5	5.7	7.3	9.3	11.7	14.7	18.2	22.9
230°	110°			4.4	5.5	7.0	9.0	11.7	14.9	18.9	23.7	30.2
212°	100°	1	4.5	5.4	6.8	8.8	11.4	15.0	19.4	25.0	31.8	41.1
194°	90°	3	5.3	6.7	8.5	11.2	14.8	19.8	26.0	34.1	44.0	57.9
176°	80°	5	6.5	8.5	11.0	14.8	19.9	27.1	36.2	48.2	63.3	84.8
158°	70°	6.2	8.5	11.1	14.8	20.2	27.7	38.5	52.4	71.1	95.2	130
140°	60°	8	12	15.1	20.6	28.7	40.2	57.2	79.6	110	151	211
122°	50°	11	15	21.5	29.9	42.9	61.5	98.7	128	181	254	365
104°	40°	15	22	32	46	68	100	150	220	320	460	680
86°	30°	21	32	50.7	75.6	116	175	271	409	613	907	1380
68°	20°	33	51	86.7	135	214	334	536	838	1290	1980	3130
50°	10°	52	87	162	264	438	711	1190	1920	3070	4870	8020
32°	0°	85	180	340	585	1020	1720	2990	5060	8400	13900	23900
14°	-10°	185	375	820	1500	2770	4880	8890	15700	27200	47000	85000
-4°	-20°	400	800	2350	4650	9120	16800	32300	60000			

Filter Design and Construction

There are two main differences in a filter. The first is the design of the filter itself, and the second is the type of media that is used in the filter.

Filter

Filters have some attributes that are immediately obvious to the casual observer, such as height, inside diameter, outside diameter, media concentration, type of liner, seal design, and the way the media and components are glued or potted together.

Liners

Liners must be structurally sturdy to withstand pressure variance, yet open enough to allow good flow.

Seals

The top seal design must be leak-free, with a gasket or sealing device that ensures a good seal throughout the life of the filter. Standard seals are made of Buna-N® material, which is fine for most applications. However, if the filtered fluid is diester or phosphate ester fluid, you'll need a seal made of a fluoroelastomer such as Viton®.

Buna-N® and Viton® are registered trademarks of E. I. DuPont de Nemours and Company.

Media Potting

Media potting is key since it holds the media in place in between the end caps (not visible). Not only should the potting be fully around the ends of the media to prevent leaks, it should also be of a material that can withstand the application. For instance, epoxy potting should be used in filters that must perform in higher temperature environments, phosphate ester fluids and some high water based fluids.



Inside the filter, the media can vary in thickness, pleat depth and pleat concentration.

For example, Donaldson hydraulic filters are generally equipped with either white ("Synteq™" our synthetic material) or natural brown (paper or cellulose material) media. **It is important to note that media colors vary according to each manufacturer – it should not be assumed that any white-colored media is made of synthetic material.**

Some of the most important characteristics of filter media (structure, fiber diameter, volume solidity, basis weight, thickness, layering) can only be detected under a microscope.

Damaged Equipment

Damage happens when key filtration points are ignored! The pistons in this pump are severely damaged from contamination in the oil.

Combining the ISO Rating and Filter Performance Ratings

While filter manufacturers publish beta ratings for filter media to describe efficiency performance levels, a direct connection between the beta rating scale and the ISO rating scale cannot be made.

The solution is monitoring filter media performance at removing particles in the 4 µm, 6 µm, and 14 µm ranges. Fluid analysis and field monitoring are the only ways to get these measurements. Combine data from several tests to form a range of performance. Remember, actual filter performance will vary between applications.

Here's how to determine which filter media will best protect your hydraulic components: plot any media performance range on the Application Guide to Donaldson Filter Media (page 158), then connect the dots to make a line. On the same graph, plot your component requirement. (Reference chart below for some popular components.) If the line of the media falls below the ISO line, or if the bottom line of the filtration range does not intersect the ISO line, the component will be protected.

Micron Sizes of Familiar Particles

Grain of table salt	100 µm
Human hair	80 µm
Lower limit of visibility	40 µm
White blood cell	25 µm
Talcum powder	10 µm
Red blood cell	8 µm
Bacteria	2 µm
Silt	<5 µm

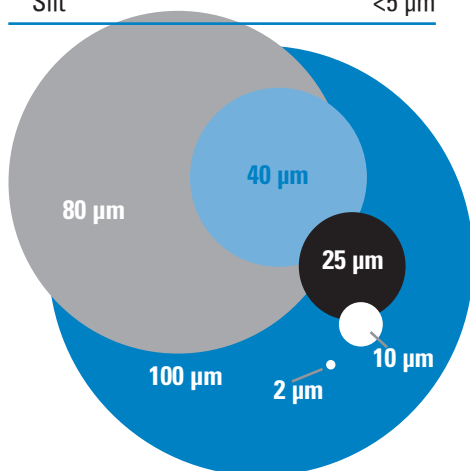

Typical ISO Cleanliness

Here are some typical ISO cleanliness recommendations from component manufacturers. (These are guidelines; always check the ratings specified by the manufacturer of your specific components.)

Pressure	<3000 PSI ≤ 210 Bar	>3000 PSI >210 Bar
Pumps	--- ISO RATINGS ---	
Fixed Gear Pump	19/17/15	18/16/13
Fixed Vane Pump	19/17/14	18/16/13
Fixed Piston Pump	18/16/14	17/15/13
Variable Vane Pump	18/16/14	17/15/13
Variable Piston Pump	17/15/13	16/14/12
Valves		
Directional (solenoid)	20/18/15	19/17/14
Pressure (modulating)	19/17/14	19/17/14
Flow Controls (standard)	19/17/14	19/17/14
Check Valves	20/18/15	20/18/15
Cartridge Valves	20/18/15	19/17/14
Load-sensing Directional Valves	18/16/14	17/15/13
Proportional Pressure Controls	18/16/13	17/15/12*
Proportional Cartridge Valves	18/16/13	17/15/12*
Servo Valves	16/14/11*	15/13/10*
Actuators		
Cylinders	20/18/15	20/18/15
Vane Motors	19/17/14	18/16/13
Axial Piston Motors	18/16/13	17/15/12
Gear Motors	20/18/15	19/17/14
Radial Piston Motors	19/17/15	18/16/13

* Requires precise sampling practices to verify cleanliness levels.
Source: Vickers

Media Application Guide and ISO Rating System

The Application Guide for Donaldson Filter Media on page 158 provides a data format for rating fluid contamination level and plotting filter media performance.

The vertical numbers on the left side of the chart represent particle counts in a logarithmic progression of ten: .01, .1, 1, 10, 102, 103, 104, 105 and 106. (This represents the number of particle in the oil sample at the given size.) The numbers across the bottom of the chart represent particle size in microns.

Donaldson media efficiency performance levels are derived from the ISO 16889 test standard with NIST-certified on-line automatic particle counters and ISO medium test dust. The Donaldson media efficiency performance levels shown are based on test averages under steady flow conditions. Actual performance levels may vary by application, viscosity, flow variance and contamination differences. Contact Donaldson or your Donaldson distributor for specific application calculations.

The international rating system for fluid contamination levels is called the ISO contamination code and it is detailed in the ISO 4406 document. Most component manufacturers publish filtration level recommendations using the ISO code. The ISO code, located on the right side of the media application guide on page 158, is easy to use if you remember the 4 μm , 6 μm and 14 μm numbers along the bottom of the chart.

Manufacturer's ISO contamination levels are based on controlling the particle counts of 4 μm , 6 μm and 14 μm particles in hydraulic system oil. This level is identified by measuring the number of particles 4 μm and greater, 6 μm

ISO 4406 Contamination Code

Range of number of particles per milliliter:

Code	More Than	Up to & Including
24	80,000	160,000
23	40,000	80,000
22	20,000	40,000
21	10,000	20,000
20	5,000	10,000
19	2,500	5,000
18	1,300	2,500
17	640	1,300
16	320	640
15	160	320
14	80	160
13	40	80
12	20	40
11	10	20
10	5	10
9	2.5	5
8	1.3	2.5
7	.64	1.3
6	.32	.64

and greater, and 14 μm and greater in one milliliter of the system hydraulic oil sample.

How to Use the ISO Rating

Example: A cartridge valve manufacturer recommends an ISO cleanliness level of 18/16/13.

- 1) On the Application Guide for Donaldson Filter Media on page 158, place a dot on the vertical 4 μm line, horizontally even with the 18 box of the ISO code.
- 2) Place a dot on the vertical 6 μm line horizontally even with the 16 box of the ISO code.
- 3) Place a dot on the vertical 14 μm line horizontally even with the 13 box of the ISO code.
- 4) Connect the dots to get the ISO cleanliness level 18/16/13.

As illustrated below, particle counts falling on and above the 18/16/13 line are damaging to the component and exceed the 18/16/13 specification set by the manufacturer.

Select a Donaldson media that falls below 18/16/13 to achieve cleanliness level tolerable to the component.

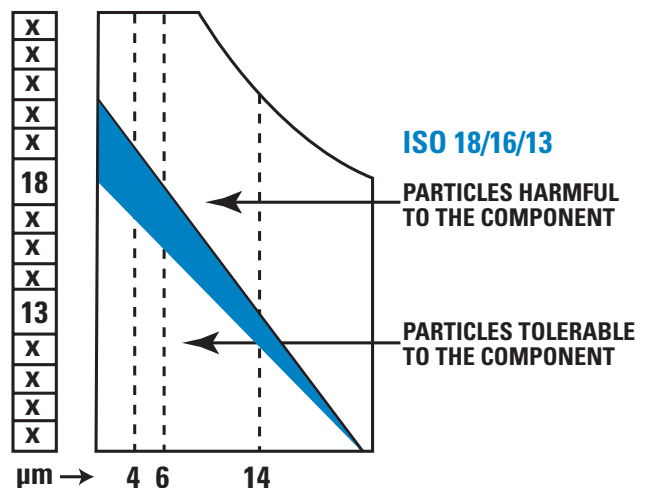

Filter Efficiency Standards

Understanding the Beta Rating System

This information is provided as an aid to understanding fluid filter efficiency terminology based on current ISO, ANSI and NFPA test standards. It is not proprietary and may be reproduced or distributed in any manner for educational purposes.

What is Beta Ratio?

Beta ratio (symbolized by β) is a formula used to calculate the filtration efficiency of a particular fluid filter using base data obtained from multi-pass testing.

In a multi-pass test, fluid is continuously injected with a uniform amount of contaminant (i.e., ISO medium test dust), then pumped through the filter unit being tested. Filter efficiency is determined by monitoring oil contamination levels upstream and downstream of the test filter at specific times. An automatic particle counter is used to determine the contamination level. Through this process an upstream to downstream particle count ratio is developed, known as the beta ratio. The formula used to calculate the beta ratio is:

$$\text{Beta ratio}_{(x)} = \frac{\text{particle count in upstream oil}^*}{\text{particle count in downstream oil}^*}$$

where (x) is a given particle size

* off all particles of size x and bigger

Indicates that testing was done with APC's calibrated with NIST fluid

$$\beta_{10(c)} = 1000$$

1000 times more particles upstream than downstream that are 10 μm and larger

Why the Efficiency Rating Test Standard was Updated

The International Industry Standard (ISO) for multi-pass testing provides a common testing format for filter manufacturers to rate filter performance. This standardization gives you the ability to reliably compare published filter ratings among different brands of filters.

ISO test standards were updated in 1999 to reflect the improved technology available in particle counters and other test equipment. The newer particle counters provide more precise counting and greater detail – reflecting a truer indication of filter performance.

The National Fluid Power Association (NFPA), the National Institute of Standards & Technology (NIST), and industry volunteers, including several engineers from Donaldson, helped revise the ISO standard. ISO 16889 has been in force since late 1999 and ISO 4572 is officially discontinued.

Better Test Dust

The old test dust (AC fine test dust or ACFTD) was “ball milled,” which produced dust particles of varying size and shape. Particle distribution was often different from batch to batch. The accuracy of ACFTD distribution and previous APC calibration procedure was questioned by industry, due to lack of traceability and certification. ACFTD hasn't been produced since 1992.

Now, the new test dust (ISO medium test dust) is “jet milled” to produce consistent particle size, shape, and distribution from batch to batch. See dust size comparison chart below.

Liquid Automatic Particle Counters (APC's)

In the old test standard (ISO 4572), fluid samples obtained in bottles and off-line particle counting were allowed. Now, in the updated standard (ISO 16889), on-line, laser-based automatic particle counters, especially made for measuring liquids, are required and bottle counting methods are disallowed, as illustrated on next page.

Find further information on ISO 16889 at www.NFPA.com or your ISO document source. Ask for ISO/TR16386: 1999 “The Impact of Changes in ISO Fluid Power Particle Counting – Contamination Control and Filter Test Standards.”

The old particle counter calibration was based on only one dimension of an irregularly-shaped particle (the longest cord). Today, the particle counter calibration is based on equivalent spherical area of an irregularly-shaped particle.

NIST provides calibration suspension, which is certified with X number of particles at a certain size. This is verified by NIST. The new way to list beta ratios includes a subscript (c) to indicate NIST certified test suspension and assures you of traceability and repeatability.

Overall, you can have strong confidence in filter ratings resulting from tests per ISO 16889, as they are highly accurate. As always, keep in mind that beta ratings are laboratory measurements under steady flow conditions with artificial contaminants – the real proof of the performance is how clean the filter keeps

the fluids in the application. A good oil analysis program that checks the cleanliness of the oil periodically will verify that the proper filters are being used.

Test Dust Size Comparisons

ACFTD calibrated size (µm) per ISO 4402 corresponds to a NIST-calibrated size [µm(c)] per ISO 11171

ACFTD	0.8	1	2	2.7	3	4.3	5	7	10	12	15	15.5	20	25	30	40	50
NIST	4	4.2	4.6	5	5.1	6	6.4	7.7	9.8	11.3	13.6	14	17.5	21.2	24.9	31.7	38.2

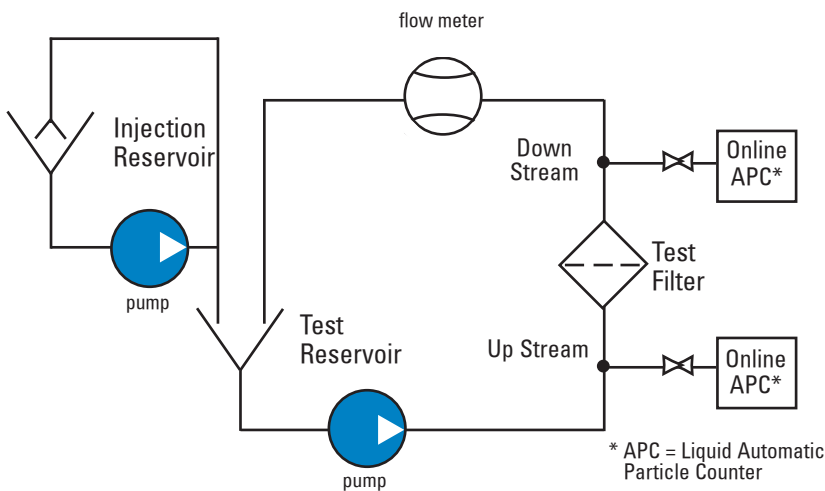

ISO 16889

- In-Line Liquid Automatic Particle Counters (APC) are now required for proper testing.
- APC calibration follows ISO 11171 procedures
- ISO 11171 uses NIST (National Institute of Standards & Technology) certified calibration fluid

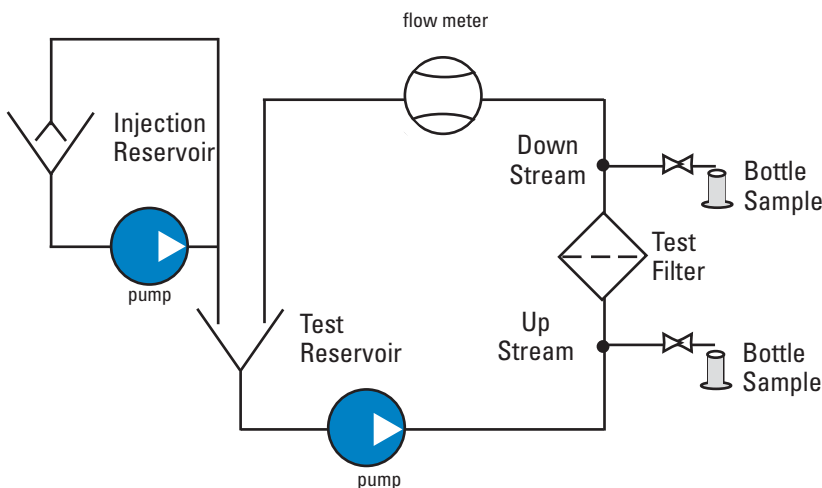

ISO 4572 (Discontinued)

- Either bottle samples or APC's were allowed.
- APC calibration followed ISO4402 ACFTD (Discontinued)

Highlights of ISO 16889

- ISO 4572 is now replaced by ISO 16889 as the international standard for Multi-Pass Tests to determine the efficiency (beta rating or beta ratio) and the dirt-holding capacity of the filter.
- The test bench for ISO 16889 must have On-Line Liquid Automatic Optical Particle Counters (APC) calibrated using NIST (National Institute of Standards & Technology)-certified calibration fluid. This includes added enhancements to APC's, to allow for better resolution, accuracy, repeatability and reproducibility.
- ISO 12103-1,A3 (ISO Medium, 5µm-80µm)
- Test Dust was selected as replacement dust for calibration and testing procedures.
- APC's are calibrated by passing a sample of calibration fluid with a known particle size distribution and producing a calibration curve to match the known count distribution.
- NIST used the Scanning Electron Microscope analysis and statistical analysis techniques to certify the particle size distribution.
- Particle counts, upstream and downstream, are taken every minute of the test.
- Beta ratios are reported with (c) to designate NIST traceability.

ISO 16889 recommends reporting beta ratings at:

Rating	Efficiency
2	50%
10	90%
75	98.7%
100	99%
200	99.5%
1000	99.9%

Example: $\beta_{4(c)} = 200$ signifies that there are 200 times as many particles that are 4 µm and larger upstream as downstream. This is 99.5% efficiency.

Example: $\beta_{5(c)} = 1000$ indicates that there are 1000 times as many particles that are 5 µm and larger upstream as downstream. This is 99.9% efficiency.

Donaldson Hydraulic Filter Media Beta Ratings

Donaldson hydraulic filter media beta ratings are average ratings obtained from multi-pass tests performed per the new ISO 16889 standard.

According to the ISO standard, each filter manufacturer can test a given filter at a variety of flow rates and terminal pressure drop ratings that fit the application, system configuration and filter size. Your actual performance may vary depending on the configuration of the filter tested and test conditions.

NEW Donaldson Filter Media Efficiency Ratings per ISO 16889 Test Standards		
Media No	Former Rating	Efficiency Rating
	Beta x µm = 2/75 per ISO 4572	Beta x µm(c) = 200/1000 per ISO 16889
Donaldson Synteq® XP Synthetic Media		
XP05		5/7
XP10		9/11
Donaldson Synteq® Synthetic Media		
# 7	7/22	25/33
# 20	20/40	42/>50
/00	<2/3	5/6
/03	7/22	18/23
Donaldson Cellulose Media		
# 10	10/25	19/23
/1	10/30	32/36
/3	25/45	46/>50

Cleanliness Level Correlation Table

Conversion of cleanliness specifications to filter performance is not an exact science because the contamination level in a hydraulic system is a function of the ingress and generation rate as well as the filter performance.

Factors That Affect Cleanliness Levels in a Hydraulic System

- Abrasive wear in space between adjacent moving surfaces of components.
- Erosive wear at component edges or direction changes where there is high fluid velocity.
- Fatigue wear by particles trapped between moving surfaces.

Identification of the Most Sensitive Component

- Required cleanliness level is dominated by the component with smallest clearances and/or highest loading on the lubricating film.
- Best source for determining this level is the specification published by the component manufacturer.
- Higher pressures reduce component life, unless contamination level is decreased accordingly.
- Operating at half the rated pressure of component will increase its life by more than four times.
- Percent of operating time at maximum pressure depends on individual machines and application.

ISO Code	Particles Per Milliliter >10 microns	ISO FTD* Gravimetric Level (mg/l)	Mil Std 1236A (1967)	NAS 1638 (1964)	SAE Level (1963)
30/26/23	140,000	1000			
29/25/23	85,000		1000		
26/25/20	14,000	100	700		
23/21/18	4,500			12	
2220/18	2,400		500		
22/20/17	2,300			11	
21/20/17	1,400	10			
21/19/16	1,200		10		
20/18/15	580			9	6
19/17/14	280		300	8	5
18/16/13	140	1		7	4
17/15/12	70			6	3
16/14/12	40		200		
16/14/10	35			5	2
15/13/10	14	0.1		4	1
14/12/9	9			3	0
13/11/8	5			2	
12/10/8	3		100		
12/10/7	2.3			1	
11/10/6	1.4	0.01			
11/9/6	1.2			0	
10/8/5	0.6			0	
9/7/5	0.3		50		
8/6/3	0.14	0.001			
7/5/2	0.04		25		
6/2/.8	0.01		10		

* SAE Fine Test Dust – ISO approved test and calibration contaminant. Source: Milwaukee School of Engineering Seminar, Contamination & Filtration of Hydraulic Systems

Cleanliness Code ISO 4406: 1999	System type	Suggested Efficiency ISO 16889	Suggested media
15/13/10	servo-valves for pressure >20MPa, laboratory & aerospace	β 2 μm(c) = 200	/00
14/16/11	high perf. & high press. long life components, i.e. small gearbox	β 2 μm(c) = 200 β 5 μm(c) = 200	/00 XP5
17/15/12	i.e. servo-valves, general power transmission gearbox	β 7 μm(c) = 200	XP5
18/16/13	high quality reliable, general purpose mach., vane & piston pumps, prop. valves, large gearbox	β 7 μm(c) = 200 β 10 μm(c) = 200	XP5 XP10
19/17/14	gear pumps	β 10 μm(c) = 200 β 12 μm(c) = 200	XP10
20/18/15	mobile equipment, medium pressure i.e. motors, valves & control	β 12 μm(c) = 200 β 15 μm(c) = 200	XP10
21/19/16	low-medium pressure systems, heavy industry, cylinders, steering unit (load sens.)	β 15 μm(c) = 200 β 20 μm(c) = 200	/03
22/20/17	low pressure systems	β 25 μm(c) = 200	/03
23/21/18	low pressure systems with large clearance	β 25 μm(c) = 200 β 10 μm(c) = 2	/03 /1 # 10
26/24/20	low pressure systems with large clearance	β 40 μm(c) = 200 β 23 μm(c) = 2	/3 # 20

Compatibility of Donaldson Filter Media with Hydraulic Fluids

While Donaldson has developed many formulations of media, they can be divided into two broad categories: natural fibers, usually cellulose, and synthetic or man-made fibers.

Petroleum-Based (Hydrocarbon) Fluids	Recommended Filter Media		
	Cellulose	Synteq	DT Synteq
Straight oils	Yes	Yes	Yes
ATFs	Yes	Yes	Yes
Military hydraulic fluids	Yes	Yes	Yes
#2 Diesel fuel	Yes	Yes	Yes
Gasoline	Yes	Yes	Yes
E85 (85/15 Ethanol/Gasoline)	No	No	Yes
Fire Resistant Fluids	Cellulose	Synteq	DT Synteq
HFA - Oil-in-water emulsion	No	<150°F	Yes
HFB - Water-in-oil emulsion	No	<150°F	Yes
HFC - Water glycol	No	<150°F	Yes
HFD Synthetics - Polyol esters, Esters, Diesters, & blends	No	Yes	Yes
HFD Synthetics - Phosphate esters	No	No	Yes
HFD Synthetics - Polyalkylene glycols (PAG), Polyalphaolefins (PAO), & blends	No	Yes	Yes
HFD Synthetics - Silicone (siloxane) oil	No	Yes	Yes
Biodegradable Fluids	Cellulose	Synteq	DT Synteq
Vegetable-based oils - sunflower, rapeseed oils	No	Yes	Yes
Synthetic oils - PAG / PAO	No	Yes	Yes
Synthetic oils - Esters, Diesters	No	Yes	Yes



Piston Pump Damage

The severe score marks on the piston slippers leave no question about why good hydraulic filtration is important.

Threads

- Gas per ISO 228/1
- M per UNI 4534-5545
- Flange connections per SAE J518 3000 PSI or 6000 PSI
- UN-UNC-UNF-UNS per ANSI/ASME B1.1
- SAE per SAE J1926-1
- NPT per ANSI/ASME 1.20.1
- NPTF per ANSI/ASME 1.20.3



Mix&Match to Get What You Need

Donaldson's Mix&Match system provides the great performance and functional advantages of custom-engineered filters with the convenience and speedy delivery of in-stock parts. Choose your options and build a filter model that exactly suits your cleanliness requirements.

Technical Data

- Operating pressure up to 1000 kPa (10 bar).
- Static pressure testing up to 1500 kPa (15 bar).
- Operating temperature -20 +120°C.
- Compatibility with hydraulic fluids per ISO 2943.
- Flow rate and pressure drop determined per ISO 3968 with oil kinematic viscosity 30 cSt at 40°C and density 0,875 kg/dm³.
- Flange per SAE J518: 3000 PSI.

Filter Elements

- Wire mesh: 60-90 micron.
- Cellulose media: 36-50 micron, reinforced with wire mesh.
- Synteq[®] synthetic media: 11-23 micron.
- By-pass valve setting 150 kPa (1,5 bar) per ISO 3968.
- Collapse resistance 1000 kPa (10 bar) per ISO 2941.
- Replacement element includes spring and O-ring seal.

Components



Family	WIRE MESH				CELLULOSE MEDIA				SYNTHETIC MEDIA				CARTRIDGE CODE
	/9		/6		/3		/1		/03		XP10		
	90µm		60µm		$\beta_{50\mu m(c)} \geq 1000$		$\beta_{36\mu m(c)} \geq 1000$		$\beta_{23\mu m(c)} \geq 1000$		$\beta_{11\mu m(c)} \geq 1000$		
	RMF		RMF	RMF		RMF		RMF	RMF		RMF		
FIO20	20	P171500	20	P171505	15	P171504	15	P171503	10	P171502	10	P171501	CR30
FIO30	30	P171500	30	P171505	20	P171504	20	P171503	15	P171502	15	P171501	CR30
FIO50	50	P171518	50	P171523	35	P171522	35	P171521	30	P171520	30	P171519	CR50
FIO60	60	P171524	60	P171529	40	P171528	40	P171527	35	P171526	35	P171525	CR60
FIO80	80	P171530	80	P171535	55	P171534	55	P171533	50	P171532	50	P171531	CR100
FIO100	80	P171530	80	P171535	65	P171534	65	P171533	60	P171533	60	P171531	CR100
FIO140	140	P171831	140	P171834	100	P171837	100	P171840	90	P171843	90	P171846	CR150
FIO150	150	P171536	150	P171541	100	P171540	100	P171539	90	P171538	90	P171537	CR180
FIO180	180	P171536	180	P171541	120	P171540	120	P171539	110	P171538	110	P171537	CR180
FIO200	200	P171542	200	P171547	140	P171546	140	P171545	130	P171544	130	P171543	CR201
FIO250	250	P171548	250	P171553	160	P171552	160	P171551	140	P171550	140	P171549	CR250
FIO325	330	P171554	330	P171559	200	P171558	200	P171557	180	P171556	180	P171555	CR325
FIO330	330	P171560	330	P171565	200	P171564	200	P171563	180	P171562	180	P171561	CR330
FIO500	500	P171566	500	P171571	400	P171570	400	P171569	350	P171568	350	P171567	CR500
FIO600	600	P171572	600	P171577	500	P171576	500	P171575	400	P171574	400	P171573	CR600
FIOF600	600	P171572	600	P171577	500	P171576	500	P171575	400	P171574	400	P171573	CR600
FIO800	800	P171578	800	P171583	600	P171582	600	P171581	500	P171580	500	P171579	CR800
FIOF800	800	P171578	800	P171583	600	P171582	600	P171581	500	P171580	500	P171579	CR800

RMF = Recommended Maximum Flow in liters/minute with use of standard housing
 Maintain the filter outlet (ref. diameter F) well below the oil level to avoid foam formation.

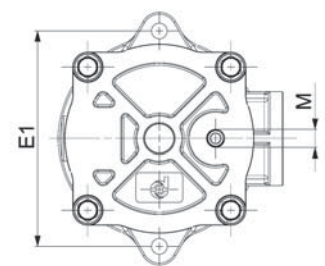
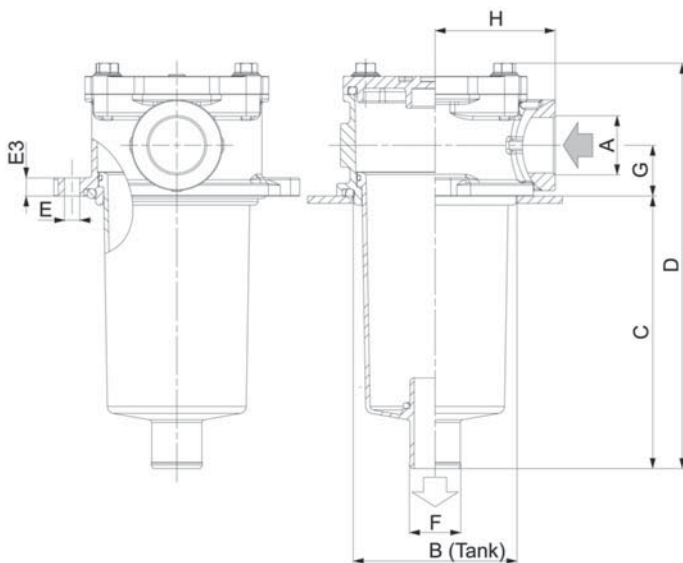

FIO 20-30

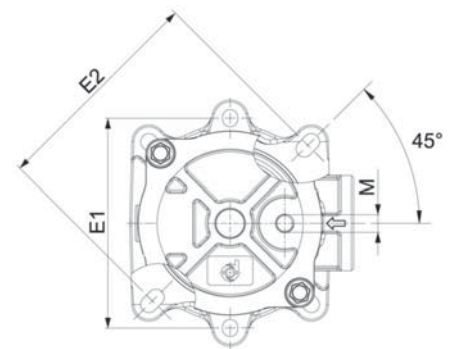

FIO 50-140



Standard Housing without Cartridge	HOUSING DIMENSIONS																CARTRIDGE DIMENSIONS			POSSIBLE INDICATOR
	A	B	C	D	E	E1	E2	E3	F	G	H	V	W	T	M	N	X	Y	Z	
		mm	mm	mm	mm	mm	mm	mm	mm	mm	mm	mm	mm	mm		predrilled holes	plugged	mm	mm	
P766446	G3/8	67	78	132	6,4	90		9	25	22	49				G1/8	yes	67	52	25.5	
P766447	G1/2	67	78	132	6,4	90		9	25	22	49				G1/8	yes	67	52	25.5	
P766448	G1/2	90	100	172	8,4	115	126	10	28	28	66				G1/8	yes	75	70	29	
P766449	G3/4	90	100	172	8,4	115	126	10	28	28	66				G1/8	yes	82	70	29	
P766450	G3/4	90	150	222	8,4	115	126	10	28	28	66				G1/8	yes	128	70	29	
P766451	G1	90	150	222	10,5	115	126	10	28	28	66				G1/8	yes	128	70	29	
P766675	G1	90	234	307	8,5	115	126	10	40	29,5	67,7				G1/8	yes	209	70	42	
P766452	G1	130	224	314	10,5	175		10	40	35	95				G1/8	yes	203	95	41	
P766453	G1 1/4	130	224	314	10,5	175		10	40	35	95				G1/8	yes	203	95	41	
P766454	G1 1/4	130	278	368	10,5	175		10	40	35	95				G1/8	yes	250	95	41	
P766455	G1 1/2	174	167	273	10,5	220		10	50	41	120				G1/8	yes	136	140	52	
P766456	G1 1/2	174	242	248	10,5	220		10	50	41	120				G1/8	yes	203	140	52	
P766457	G1 1/2	174	240	346	10,5	220		10	63,5	41	120				G1/8	yes	203	140	65	
P766458	G2	174	240	346	10,5	220		10	63,5	41	120				G1/8	yes	203	140	65	
P766459	G2	174	294	400	10,5	220		10	63,5	41	120				G1/8	yes	250	140	65	
P766460	Flange 2"	174	290	395,5	10,5	220		11	63,5	48,5	120	77,8	42,9	M12	G1/8	yes	250	140	65	
P766461	G2	174	437	543	10,5	220		10	63,5	41	120				G1/8	yes	400	140	65	
P766462	Flange 2"	174	433	538	10,5	220		11	63,5	48,5	120	77,8	42,9	M12	G1/8	yes	400	140	65	

P171953
P171958
P171966
P173104

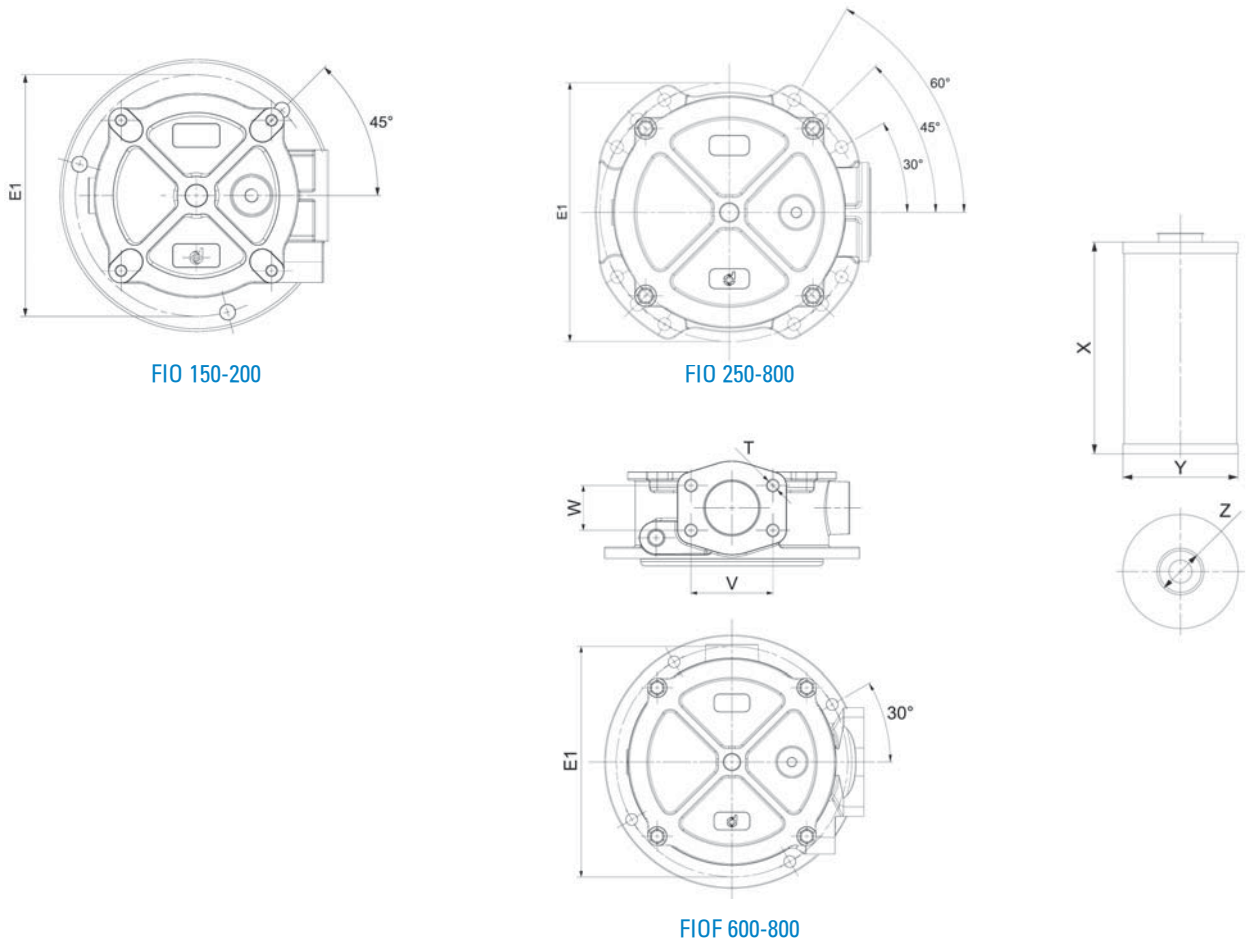

Indicator Choices

Indicator	Kind	Reference Drawing	Setting (bar)	Contact	Protection Class	Cable Clamp	Max. Values
P171966	Electrical	C	1,2	Normally Open	IP65	PG7	48 V; 0,5 A res. and 0,2 A ind.
P173104	Electrical	C	1,2	Normally Closed	IP65	PG7	48 V; 0,5 A res. and 0,2 A ind.
P171958	Visual	F	1,2				
P171953	Visual	G	range -1/5				

Installation & Service Guidelines

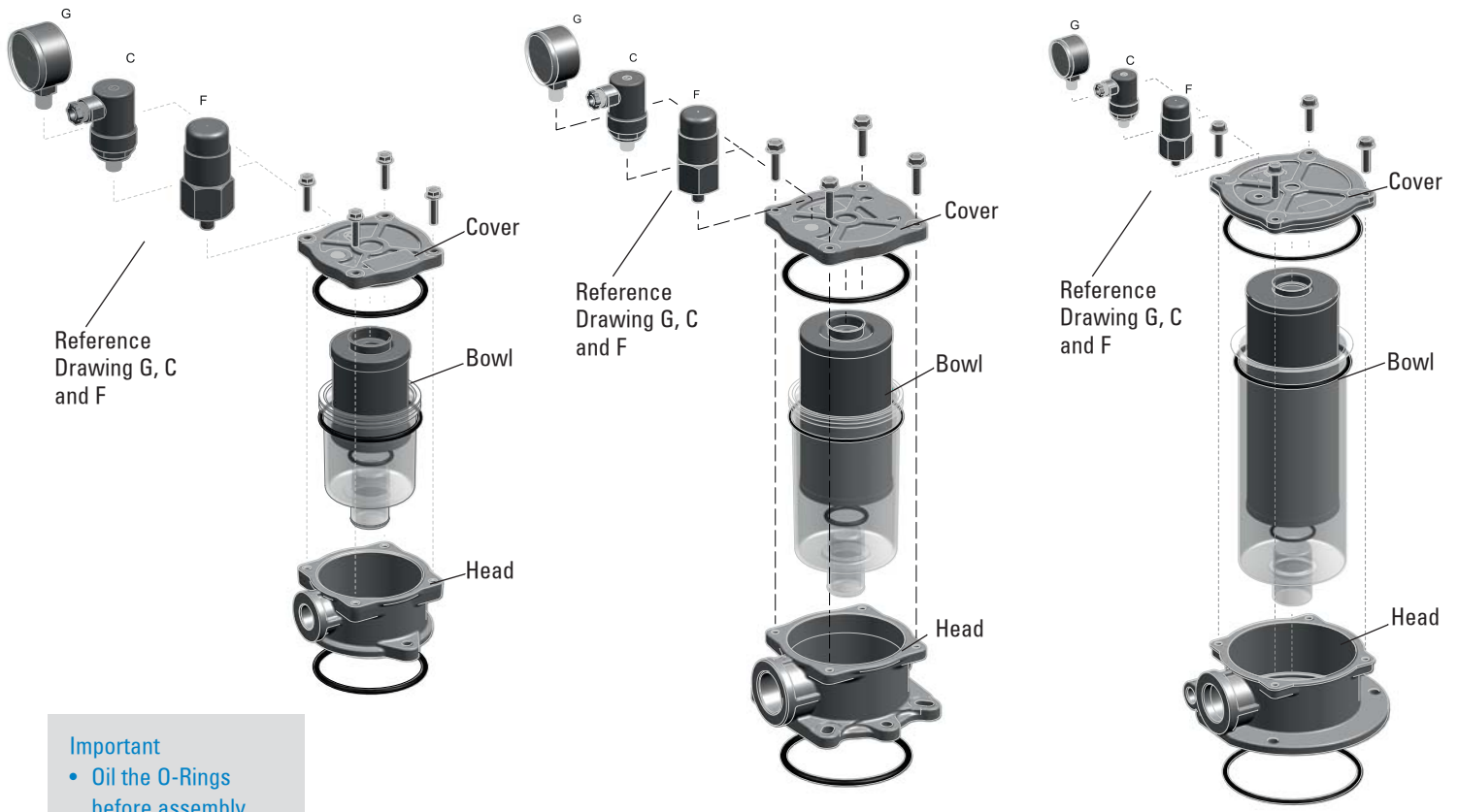

Important

- Oil the O-Rings before assembly.

FIO 20-30

FIO 50-140

FIO 150-800

Performance Curves

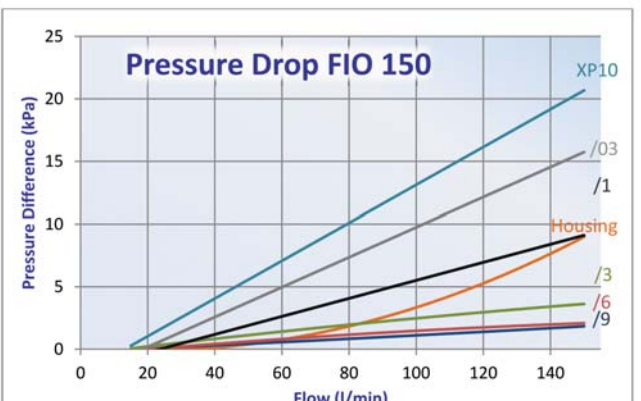
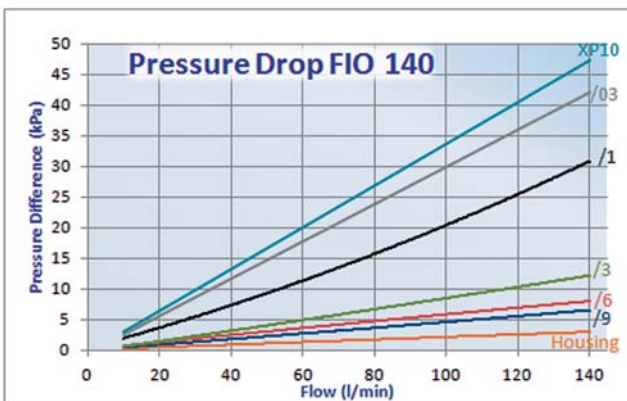
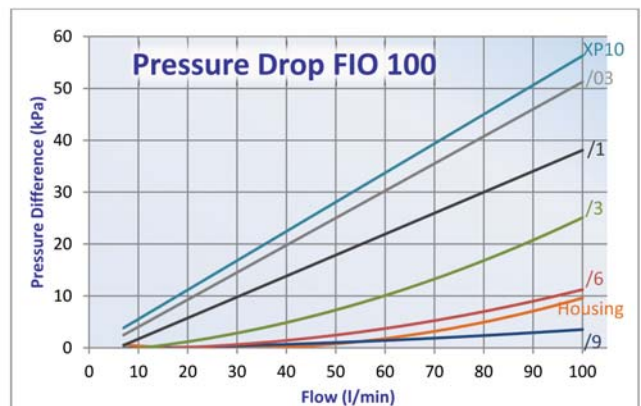
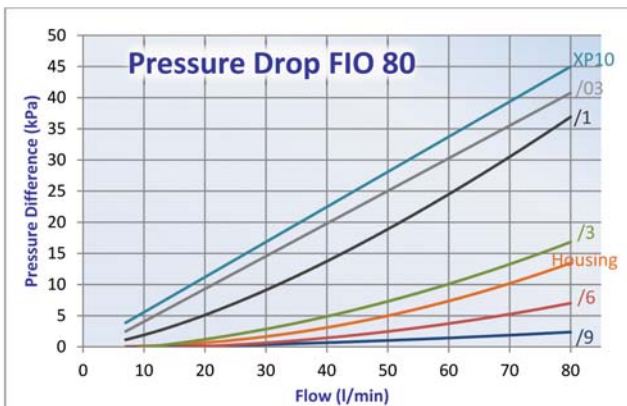
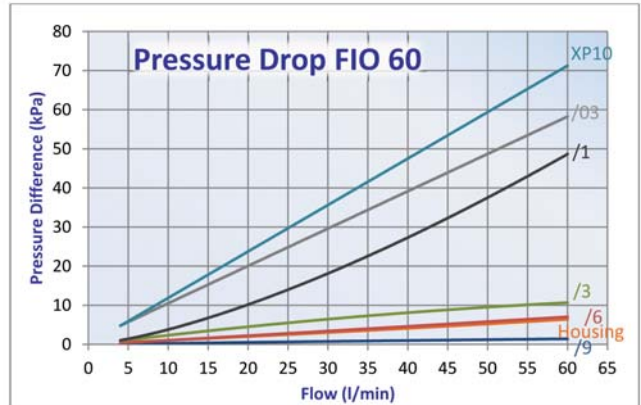
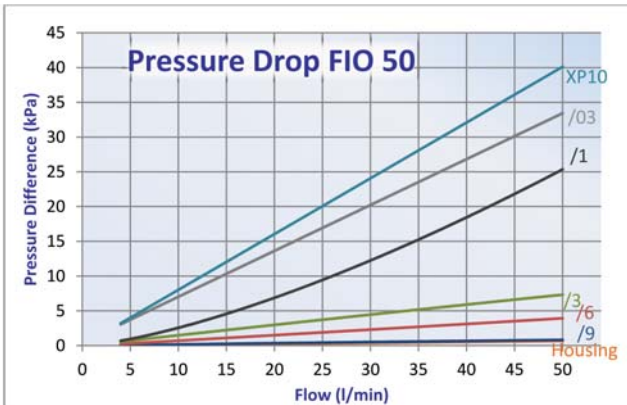
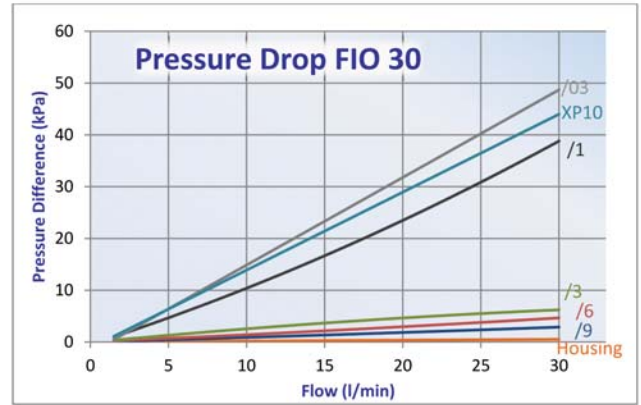
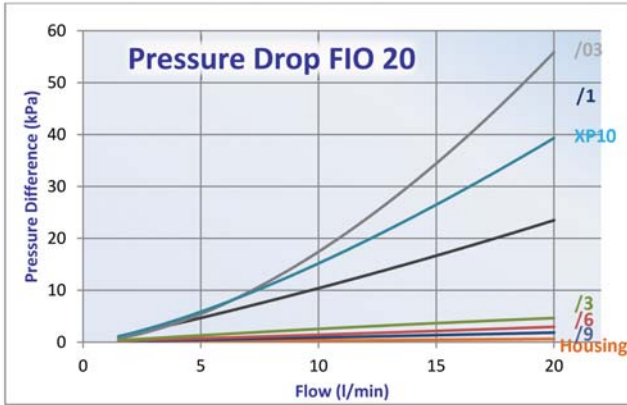

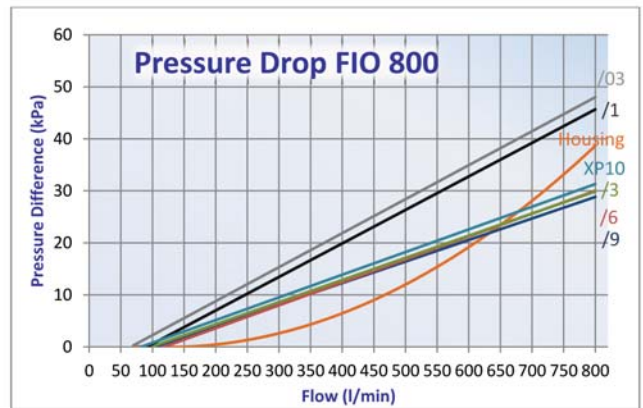
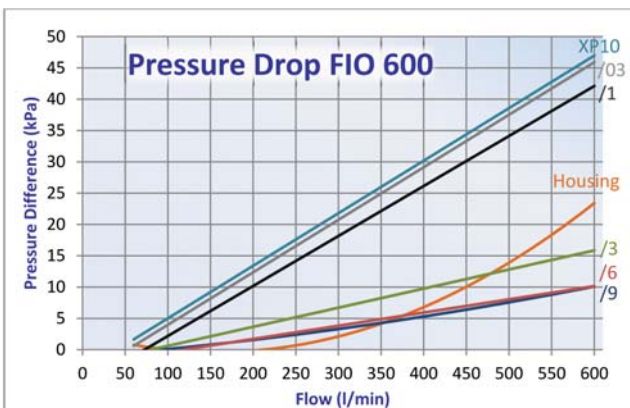
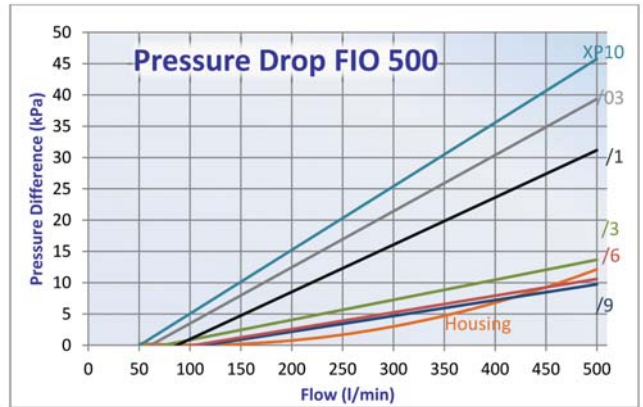
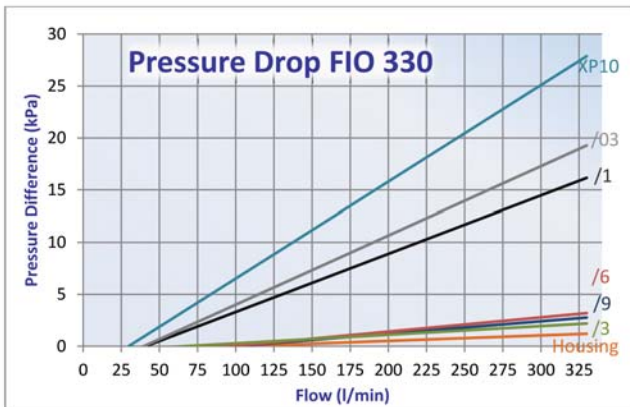
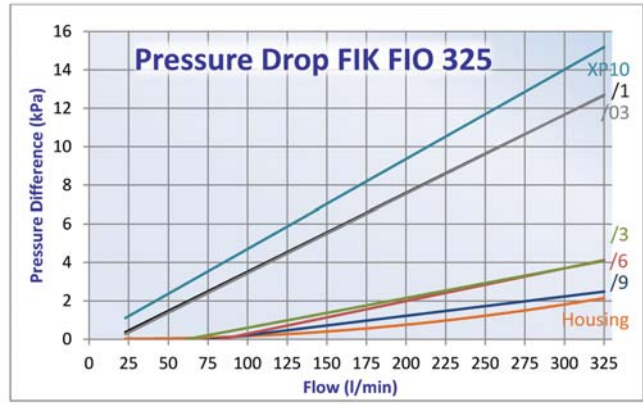
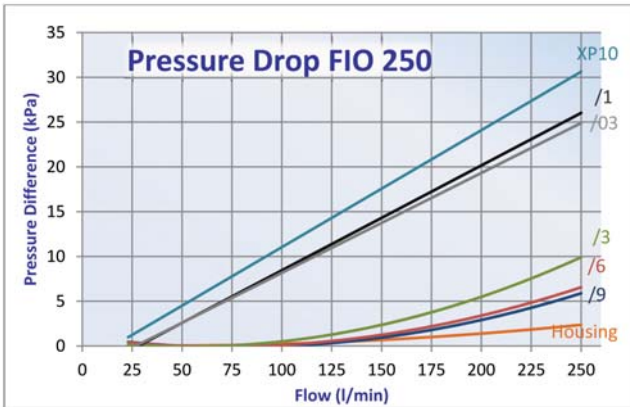
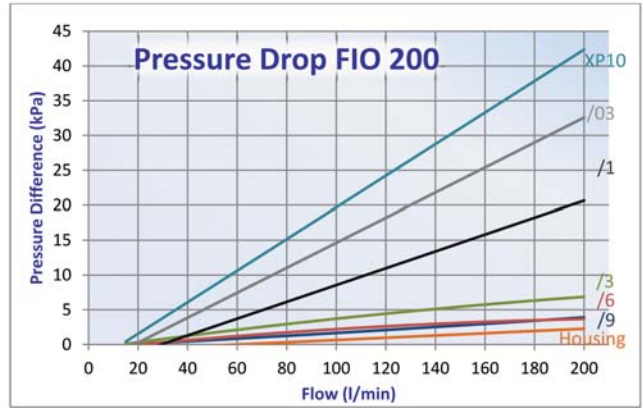
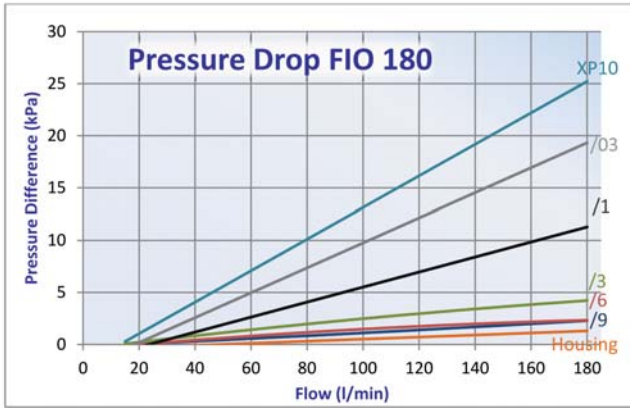

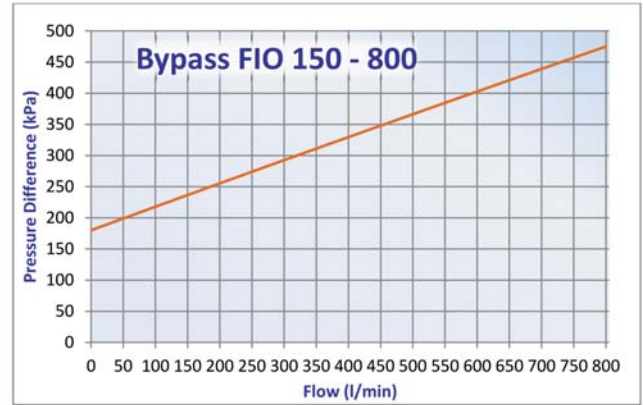
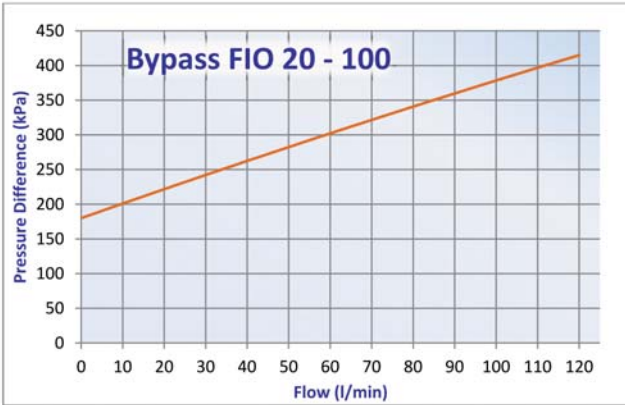

FIK-FIO(T)
FHK-FIR
SRK-Combo
200 + 300

Open empty housing
in correct order

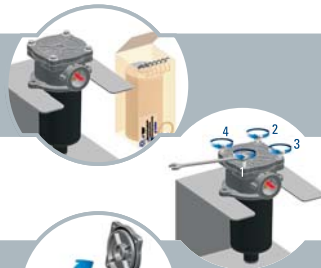

Remove carton ring
before use



Check if O-ring between
lid and housing is installed and intact



Check if O-Ring on cartridge is installed and intact



For FIK:
Mount O-ring over stud



For Low Pressure cartridges:
Mount spring on cartridge



Mount element in
housing



For Combo 120:
Align arrows as shown



Assemble lid on housing



Assemble bolts and
screws in correct order

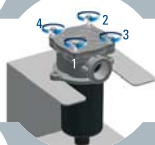

Tighten screws, bolts or lid until thread ends
For spin-ons: hand tighten until contact
between O-ring and head is made; and then
continue by hand as indicated on spin-on



Degrease surface where sparepart sticker
will be mounted
Only for cartridge type filters



Sparepart sticker in each sparepart box



Fix sparepart sticker in area indicated—
Ready!



Do not forget seals



Mix&Match to Get What You Need

Donaldson's Mix&Match system provides the great performance and functional advantages of custom-engineered filters with the convenience and speedy delivery of in-stock parts. Choose your options and build a filter model that exactly suits your cleanliness requirements.

Technical Data

- Operating pressure up to 1000 kPa (10 bar).
- Static pressure testing up to 1500 kPa (15 bar).
- Operating temperature -20 +120°C.
- Compatibility with hydraulic fluids per ISO 2943.
- Flow rate and pressure drop determined per ISO 3968 with oil kinematic viscosity 30 cSt at 40°C and density 0,875 kg/dm³.
- Flange per SAE J518: 3000 PSI.

Filter Elements

- Wire mesh: 60-90 micron.
- Cellulose media: 36-50 micron, reinforced with wire mesh.
- Synteq[®] synthetic media: 11-23 micron.
- By-pass valve setting 150 kPa (1,5 bar) per ISO 3968.
- Collapse resistance 1000 kPa (10 bar) per ISO 2941.
- Replacement element includes spring and O-ring seal.



Components

Family	WIRE MESH				CELLULOSE MEDIA				SYNTHETIC MEDIA				CARTRIDGE CODE
	/9		/6		/3		/1		/03		XP10		
	90µm		60µm		$\beta_{50\mu m(c)} \geq 1000$		$\beta_{38\mu m(c)} \geq 1000$		$\beta_{23\mu m(c)} \geq 1000$		$\beta_{11\mu m(c)} \geq 1000$		
	RMF		RMF	RMF		RMF		RMF	RMF		RMF		
FIOT20	20	P171500	20	P171505	15	P171504	15	P171503	10	P171502	10	P171501	CR30
FIOT30	30	P171500	30	P171505	20	P171504	20	P171503	15	P171502	15	P171501	CR30
FIOT50	50	P171518	50	P171523	35	P171522	35	P171521	30	P171520	30	P171519	CR50
FIOT60	60	P171524	60	P171529	40	P171528	40	P171527	35	P171526	35	P171525	CR60
FIOT80	80	P171530	80	P171535	55	P171534	55	P171533	50	P171532	50	P171531	CR100
FIOT100	100	P171530	100	P171535	65	P171534	65	P171533	60	P171532	60	P171531	CR100
FIOT140	140	P171831	140	P171834	100	P171837	100	P171840	60	P171843	60	P171846	CR150
FIOT150	150	P171536	150	P171541	100	P171540	100	P171539	90	P171538	90	P171537	CR180
FIOT180	180	P171536	180	P171541	120	P171540	120	P171539	110	P171538	110	P171537	CR180
FIOT200	200	P171542	200	P171547	140	P171546	140	P171545	130	P171544	130	P171543	CR201
FIOT250	250	P171548	250	P171553	160	P171552	160	P171551	140	P171550	140	P171549	CR250
FIOT325	330	P171554	330	P171559	200	P171558	200	P171557	180	P171556	180	P171555	CR325
FIOT330	330	P171560	330	P171565	200	P171564	200	P171563	180	P171562	180	P171561	CR330
FIOT500	500	P171566	500	P171571	400	P171570	400	P171569	350	P171568	350	P171567	CR500
FIOT600	600	P171572	600	P171577	500	P171576	500	P171575	400	P171574	400	P171573	CR600
FIOTF600	600	P171572	600	P171577	500	P171576	500	P171575	400	P171574	400	P171573	CR600
FIOT800	800	P171578	800	P171583	600	P171582	600	P171581	500	P171580	500	P171579	CR800
FIOTF800	800	P171578	800	P171583	600	P171582	600	P171581	500	P171580	500	P171579	CR800

RMF = Recommended Maximum Flow in liters/minute with use of standard housing.
Maintain the filter outlet (ref. diameter F) well below the oil level to avoid foam formation.

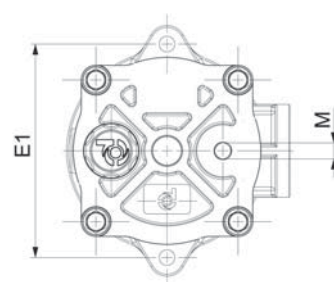
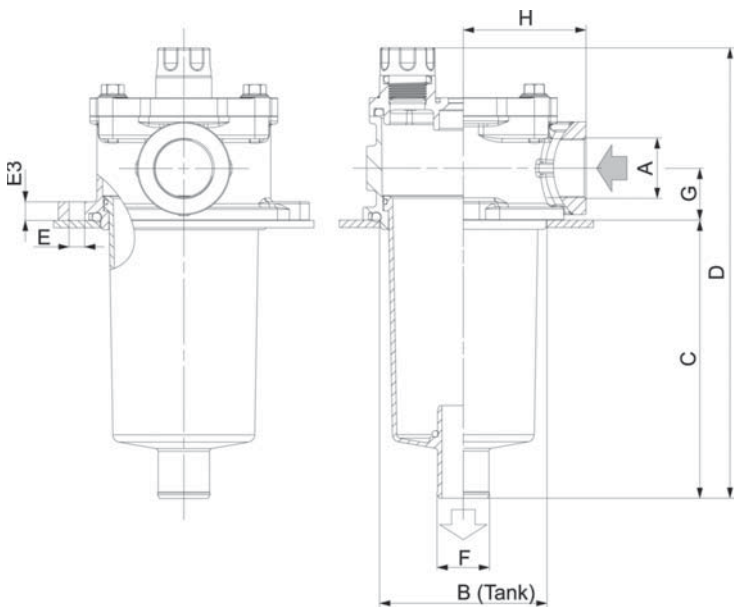

FIOT 20-30

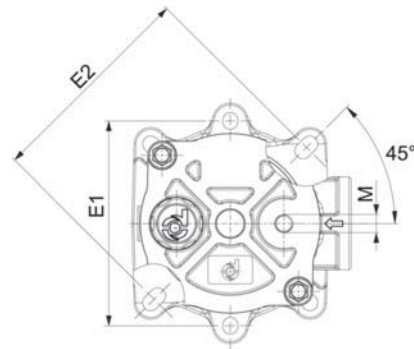

FIOT 50-140



Standard Housing without Cartridge	HOUSING DIMENSIONS																CARTRIDGE ELEMENT			POSSIBLE INDICATOR
	A	B	C	D	E	E1	E2	E3	F	G	H	M	N	V	W	T	X	Y	Z	
		mm	mm	mm	mm	mm	mm	mm	mm	mm	mm	predrilled holes	plugged	mm	mm		mm	mm	mm	
P766463	G3/8	69	78	132	6,4	90		9	25	22	49	G1/8	yes				67	52	25,5	
P766464	G1/2	69	78	132	6,4	90		9	25	22	49	G1/8	yes				67	52	25,5	
P766465	G1/2	92	100	172	8,4	115	126	10	28	28	66	G1/8	yes				75	70	29	
P766466	G3/4	92	100	172	8,4	115	126	10	28	28	66	G1/8	yes				82	70	29	
P766467	G3/4	92	150	222	8,4	115	126	10	28	28	66	G1/8	yes				128	70	29	
P766468	G1	92	150	222	8,4	115	126	10	28	28	66	G1/8	yes				128	70	29	
P766674	G1	92	226	320	8,5	115	126	10	40	29,5	67,7	G1/8	yes				209	70	42	
P766469	G1	132	224	314	10,5	175		10	40	35	95	G1/8	yes				203	95	41	
P766470	G1 1/4	132	224	314	10,5	175		10	40	35	95	G1/8	yes				203	95	41	
P766471	G1 1/4	132	278	368	10,5	175		10	40	35	95	G1/8	yes				250	95	41	
P766472	G1 1/2	176	167	273	10,5	220		10	50	41	120	G1/8	yes				136	140	52	
P766473	G1 1/2	176	242	348	10,5	220		10	50	41	120	G1/8	yes				203	140	52	
P766474	G1 1/2	176	240	346	10,5	220		10	63,5	41	120	G1/8	yes				203	140	65	
P766475	G2	176	240	346	10,5	220		10	63,5	41	120	G1/8	yes				203	140	65	
P766476	G2	176	294	400	10,5	220		10	63,5	41	120	G1/8	yes				250	140	65	
P766477	Flange 2	176	290	395,5	10,5	220		11	63,5	48,5	120	G1/8	yes	77,8	42,9	M12	250	140	65	
P766478	G2	176	437	543	10,5	220		10	63,5	41	120	G1/8	yes				400	140	65	
P766479	Flange 2	176	433	538	10,5	220		11	63,5	48,5	120	G1/8	yes	77,8	42,9	M12	400	140	65	

P171953
P171958
P171966
P173104

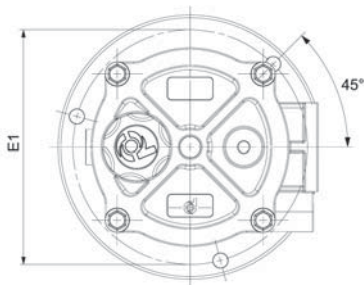

FIOT 150-200

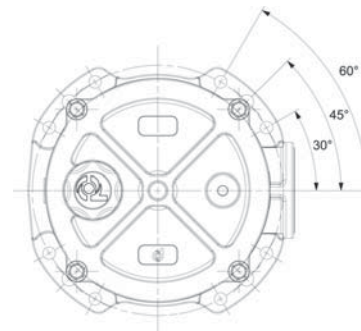

FIOT 250-800

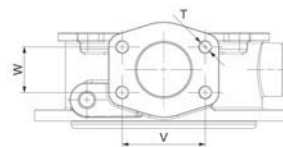

FIOTF 600-800

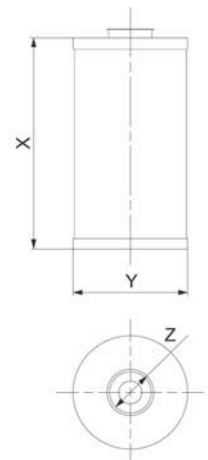

Indicator Choices

Indicator	Kind	Reference Drawing	Setting (bar)	Contact	Protection Class	Cable Clamp	Max. Values
P171966	Electrical	C	1,2	Normally Open	IP65	PG7	48 V; 0,5 A res. and 0,2 A ind.
P173104	Electrical	C	1,2	Normally Closed	IP65	PG7	48 V; 0,5 A res. and 0,2 A ind.
P171958	Visual	F	1,2				
P171953	Visual	G	range -1/5				

Installation & Service Guidelines

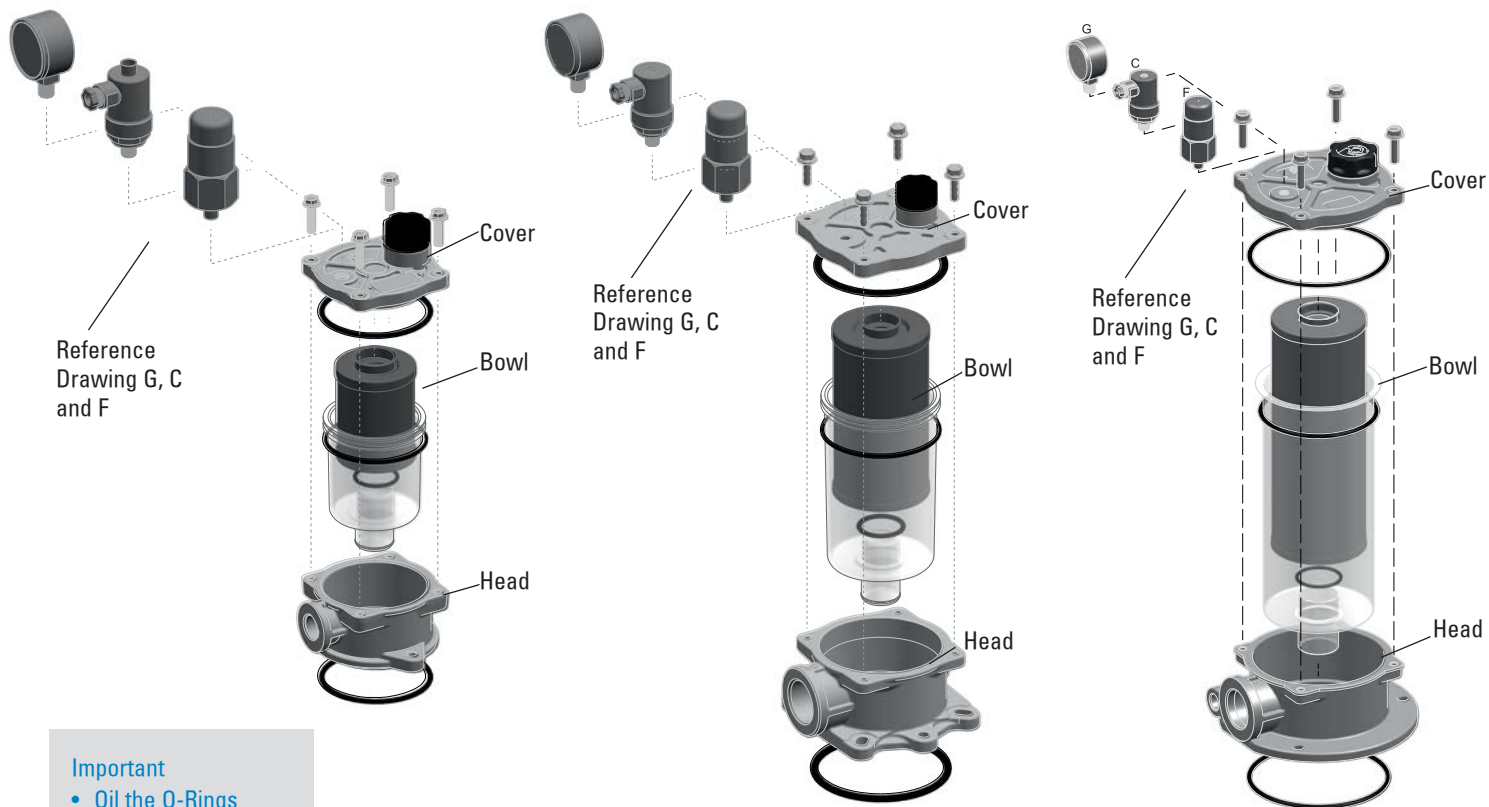

Important
 • Oil the O-Rings
 before assembly.

FIOT 20-30

FIOT 50-140

FIOT 150-800

Performance Curves

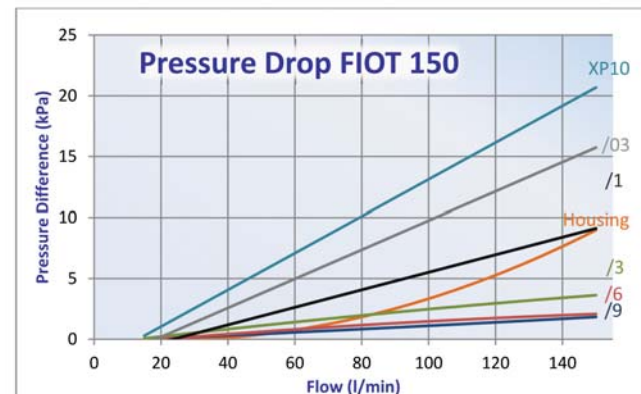
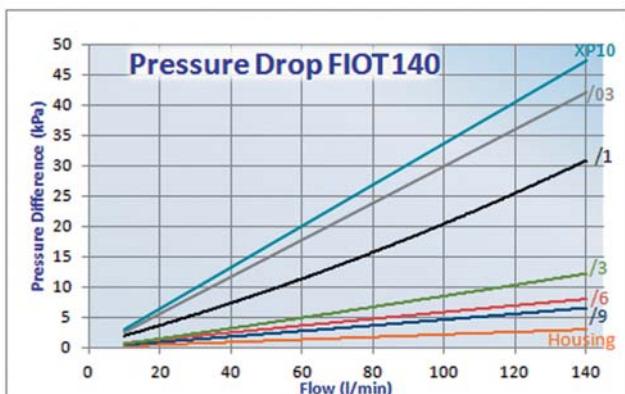
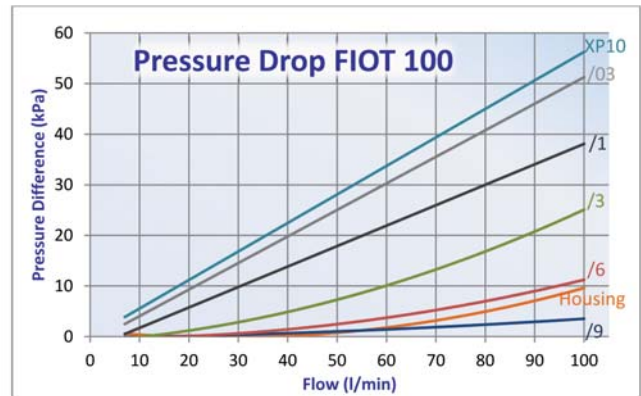
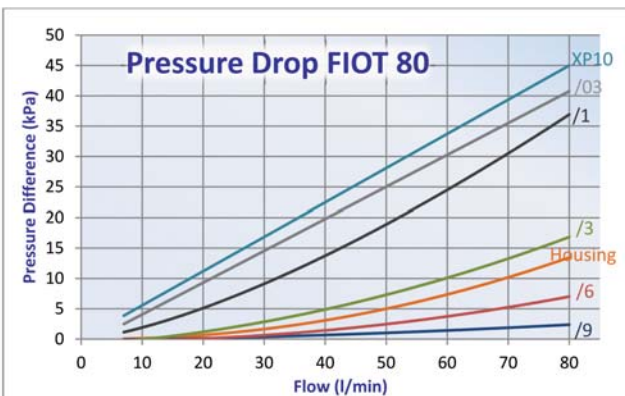
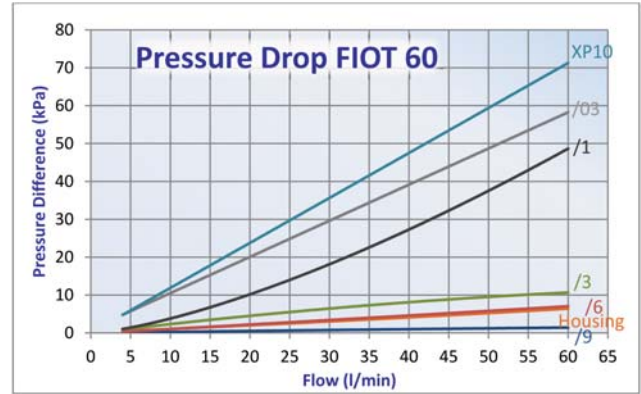
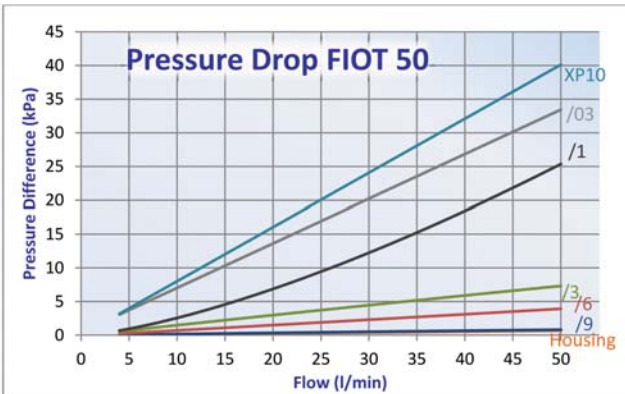
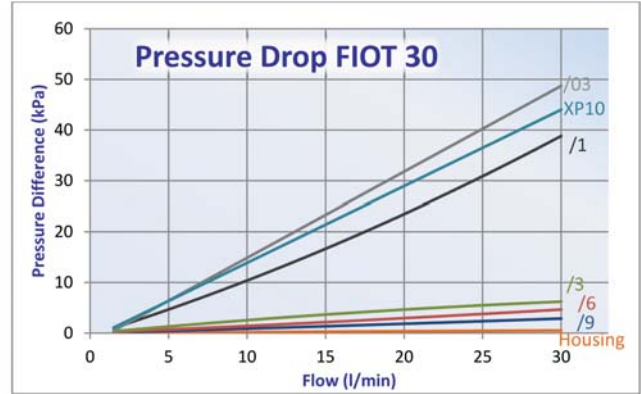
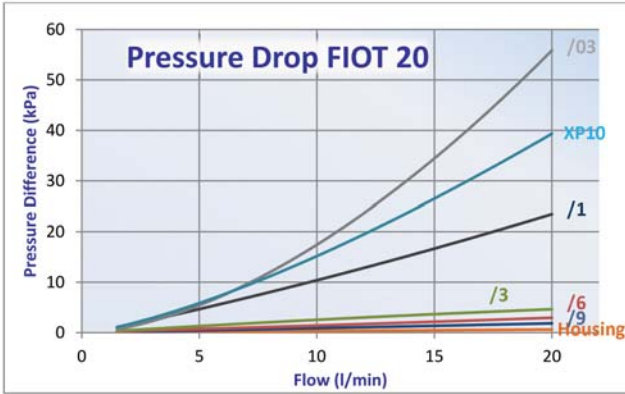

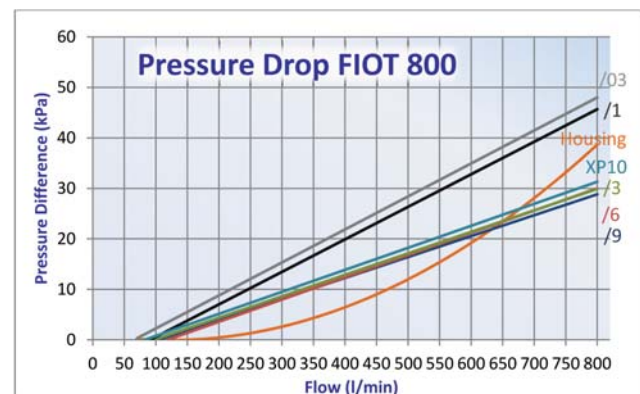
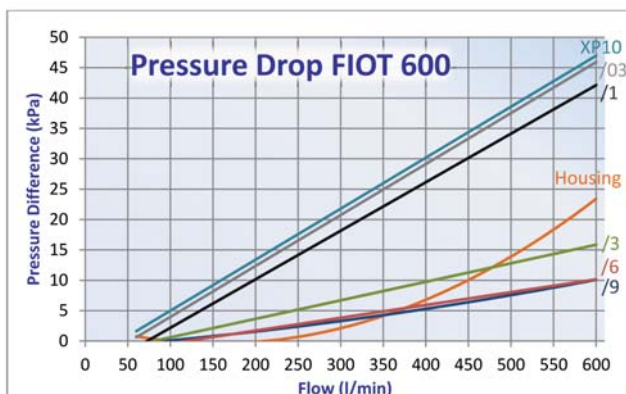
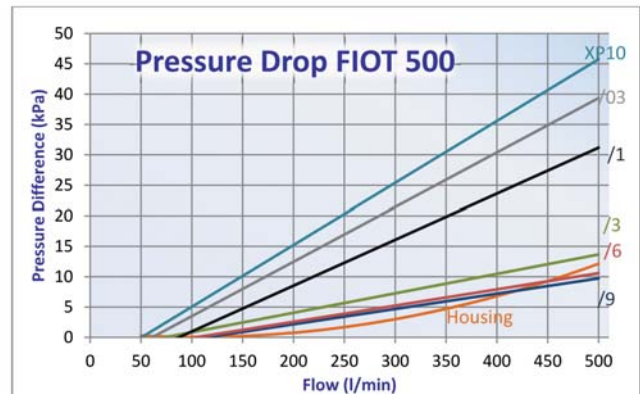
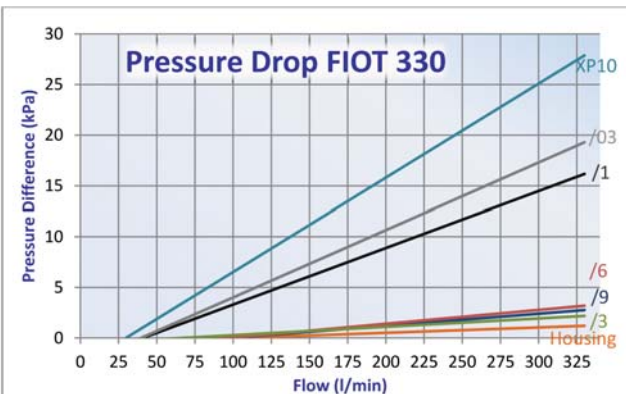
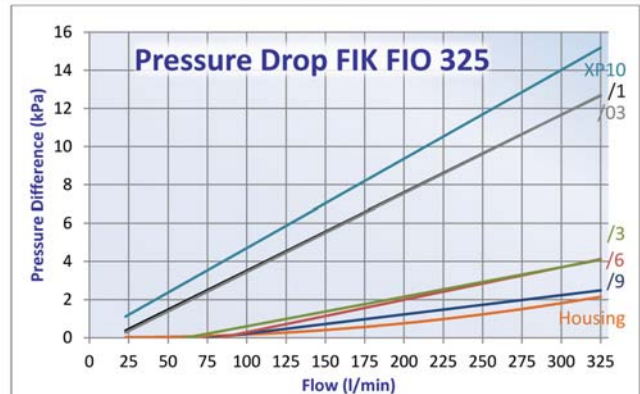
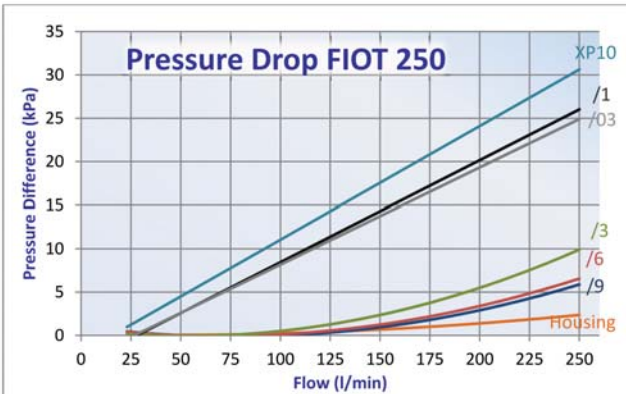
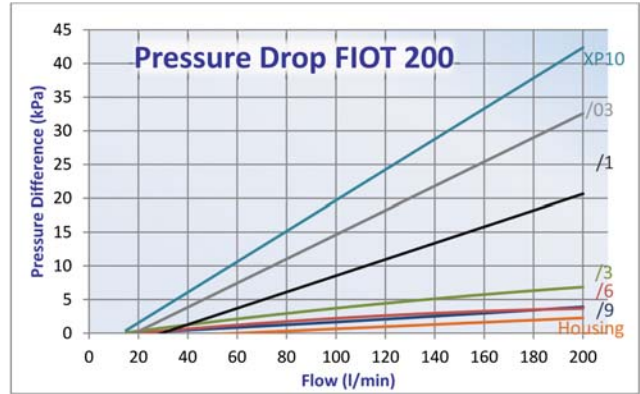
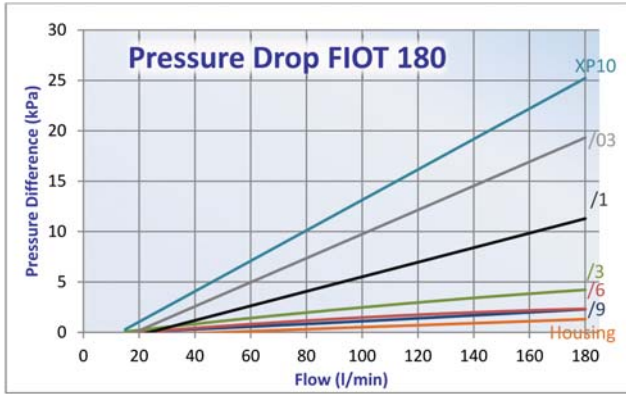

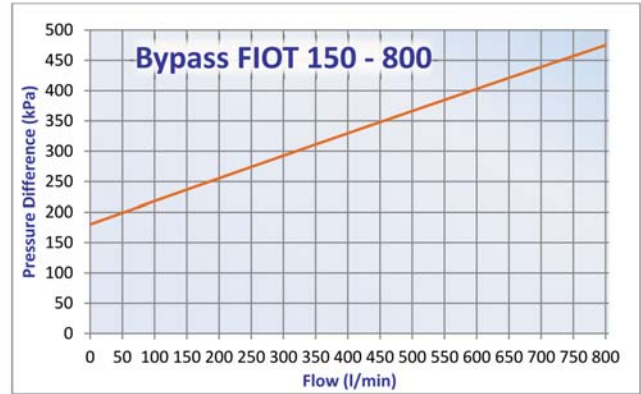
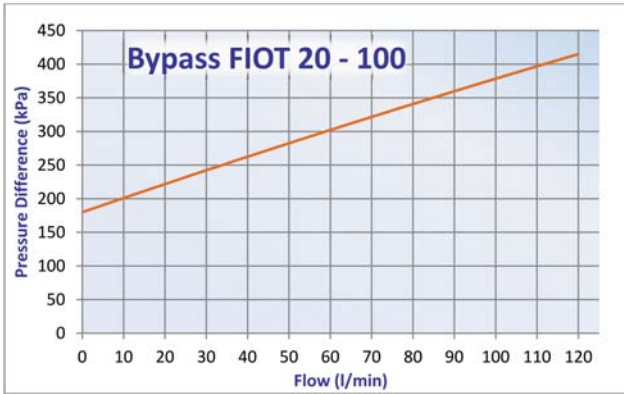



Donaldson.
FILTRATION SOLUTIONS

Donaldson Engine E-Catalogues

Check out Donaldson's Engine E-catalogue by clicking or browsing to one of the below links:

www.donaldson-catalogue.com/air

www.donaldson-catalogue.com/hydraulic

www.donaldson-catalogue.com/liquid

www.donaldson-catalogue.com/agriculture

www.donaldson-catalogue.com/truckBus

www.donaldson-catalogue.com/forklift

www.donaldson-catalogue.com/exhaust

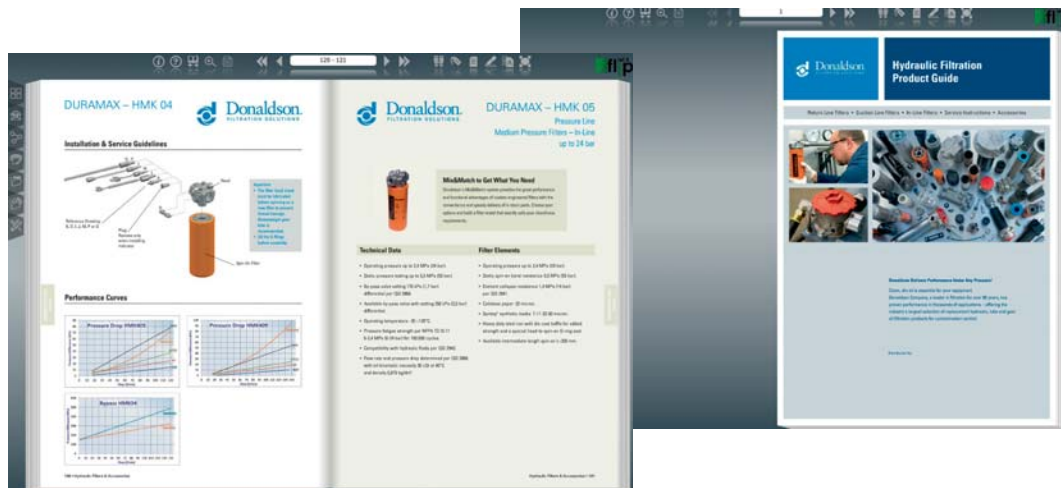

An E-Catalogue is an interactive format of a standard pdf with handy search functions. No password required!

REMARK: If the E-Catalogue doesn't open, it means that Adobe Flash Player is not installed on your computer.



Mix&Match to Get What You Need

Donaldson's Mix&Match system provides the great performance and functional advantages of custom-engineered filters with the convenience and speedy delivery of in-stock parts. Choose your options and build a filter model that exactly suits your cleanliness requirements.

Technical Data

- Operating pressure up to 1000 kPa (10 bar).
- Static pressure testing up to 1500 kPa (15 bar).
- Operating temperature -20 +120°C.
- Compatibility with hydraulic fluids per ISO 2943.
- Flow rate and pressure drop determined per ISO 3968 with oil kinematic viscosity 30 cSt at 40°C and density 0,875 kg/dm³.

Filter Elements

- Wire mesh: 60-90 micron.
- Cellulose media: 36-50 micron, reinforced with wire mesh.
- Synteq® synthetic media: 11-23 micron.
- By-pass valve setting 150 kPa (1,5 bar) per ISO 3968.
- Collapse resistance 1000 kPa (10 bar) per ISO 2941.
- Replacement element includes spring and O-ring seal.

Components



RESTYLED

NEW

Family	WIRE MESH				CELLULOSE MEDIA				SYNTHETIC MEDIA				CARTRIDGE CODE
	/9		/6		/3		/1		/03		XP10		
	90µm		60µm		β _{50µm(c)} ≥1000		β _{36µm(c)} ≥1000		β _{23µm(c)} ≥1000		β _{11µm(c)} ≥1000		
	RMF			RMF		RMF		RMF		RMF			
FIS20	20	P171829	20	P171832	15	P171835	15	P171838	10	P171841	10	P171844	CR20
FIS40	40	P171830	40	P171833	30	P171836	30	P171839	25	P171842	25	P171845	CR40
FIS50	40	P171830	40	P171833	30	P171836	30	P171839	25	P171842	25	P171845	CR50
FIS60	60	P171524	60	P171529	40	P171528	40	P171527	35	P171526	35	P171525	CR60
FIS100	100	P171530	100	P171535	65	P171534	65	P171533	60	P171532	60	P171531	CR100
FIS150	150	P171831	150	P171834	120	P171837	120	P171840	110	P171843	110	P171846	CR150
FIS200	200	P766606	200	P766607	150	P766608	150	P766609	130	P766610	130	P766611	CR200

RMF = Recommended Maximum Flow in liters/minute with use of standard housing.
S= Service Clearance
Maintain the filter outlet (ref. diameter G) well below the oil level to avoid foam formation.

Breather Choices



Family	NO MEDIA	CELLULOSE MEDIA				REMARK
	closes of breather hole	Without pressurization		With pressurization relief setpoint at 0.4 bar		
		RMF	10µm	RMF	10µm	
FIS20, 40, 50	P766927 (plug)	150	P567392 (black)	150	not available	Breather with T.R.A.P.™ Technology
FIS60, 100, 150, 200	P766528 (black)	150	P766530 (blue)	150	P766538 (red)	Breather with T.R.A.P.™ Technology

The head is open, to avoid contamination entering the tank, you have to install a breather.

Dipstick Choices



For Family	DIPSTICK	IN TANK LENGTH	USE HOLE DIAMETER
FIS20	P766623	138	M10
FIS40, 50	P766624	293	M10
FIS60, 100	P766552	150	E or F
FIS150, 200	P766621	305	E or F

Standard Housing without Cartridge and without breather	HOUSING DIMENSIONS																		CARTRIDGE DIMENSIONS			POSSIBLE INDICATORS		
	A	B	C	D	E	E1	E2	E3	F	F1	F2	F3	G	H	J	K	L	M	N	S	X		Y	Z
		mm	mm	mm	mm	mm	mm	mm	mm	mm	mm	mm	mm	mm	mm	mm	mm	mm	predrilled holes	plugged	mm		mm	mm
P766618	G3/8	59	115	183	11	84	90	11	11	82	90	11	20	48	65	21	74	2x G1/8	YES	100	43	98	22	P171953 P171958 P171966 P173104
P766619	G1/2	59	180	248	11	84	90	11	11	82	90	11	20	48	65	21	74	2x G1/8	YES	164	43	162	22	
NEW	G3/4	59	180	248	11	82	90	11,5	11	84	90	11,5	20	50	50	21	74	2x G1/8	YES	164	43	162	22	
P766597	G3/4	90	91	189	8,5	126	130	12	11	112	116	14	27,6	70,5	94,5	32	116	2x G1/8	YES	84	70	82	29	
P766598	G1	90	141	239	8,5	126	130	12	11	112	116	14	27,6	70,5	94,5	32	116	2x G1/8	YES	130	70	128	29	
P766599	G1 1/4	90	218	316	8,5	126	130	12	11	112	116	14	39,6	70,5	94,5	32	116	2x G1/8	YES	212	70	210	42	
P766595	G1 1/2	90	400	432	8,5	126	130	12	11	112	116	14	39,6	70,5	94,5	32	116	2x G1/8	YES	289	70	287	42	

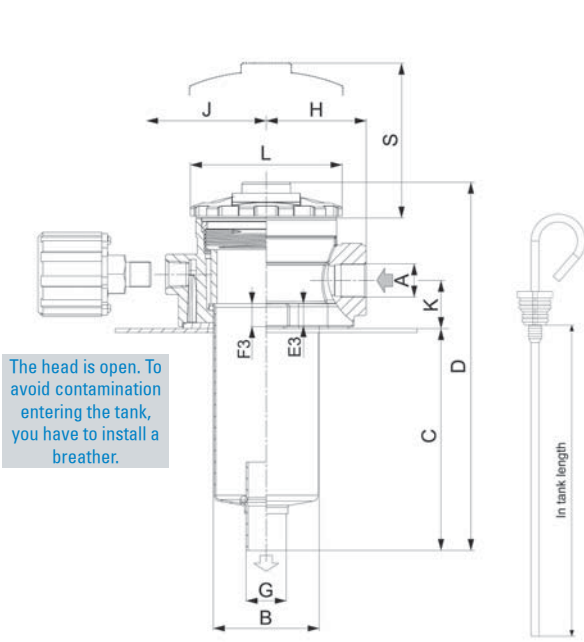

FIS 20-40

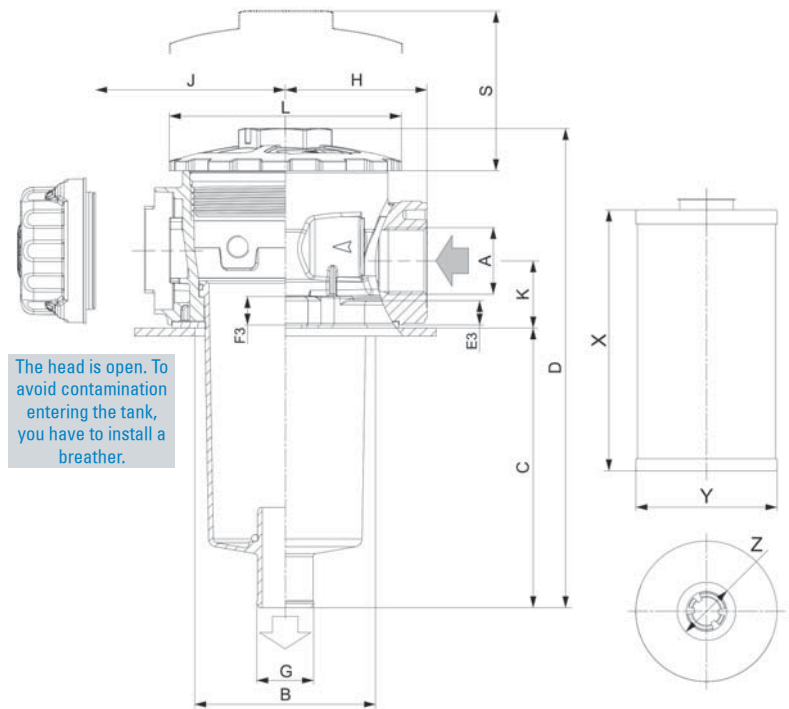

FIS 60-200

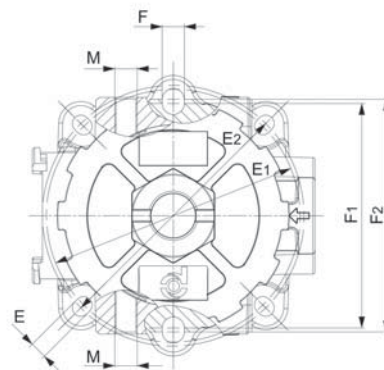
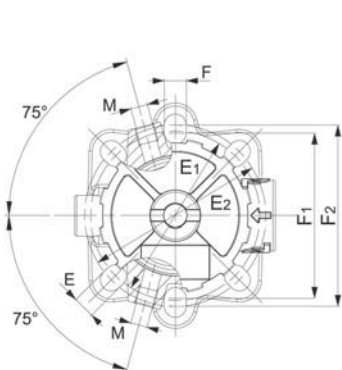

Indicator Choices

Part	Kind	Reference Drawing	Setting (bar)	Contact	Protection Class	Cable Clamp	Max. Values
P171966	Electrical	C	1,2	Normally Open	IP65	PG7	48 V; 0,5 A res. and 0,2 A ind.
P173104	Electrical	C	1,2	Normally Closed	IP65	PG7	48 V; 0,5 A res. and 0,2 A ind.
P171958	Visual	F	1,2				
P171953	Visual	G	range -1/5				
P171954	Visual	G	range -1/3				



Installation & Service Guidelines

Important

- Oil the O-Rings before assembly.

Labels: Breather, G, C, F, Reference Drawing G, C or F, Cover, O-ring, Dipstick, Bowl, Head, Gasket.

RESTYLED

Labels: Breather, Cover, O-ring, Dipstick, Bowl, Head, Gasket, Reference Drawing G, C or F.

FIS 20-50

FIS 60-200

Performance Curves

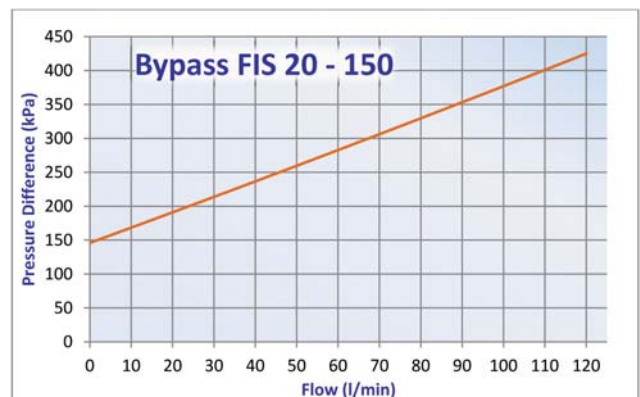
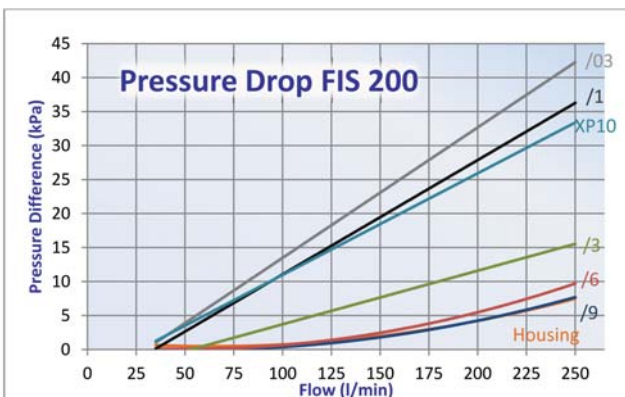
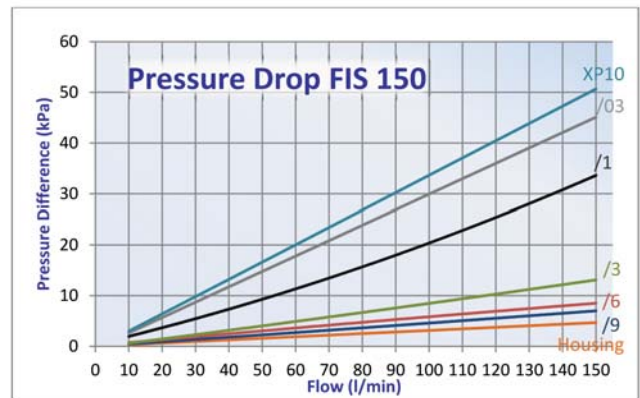
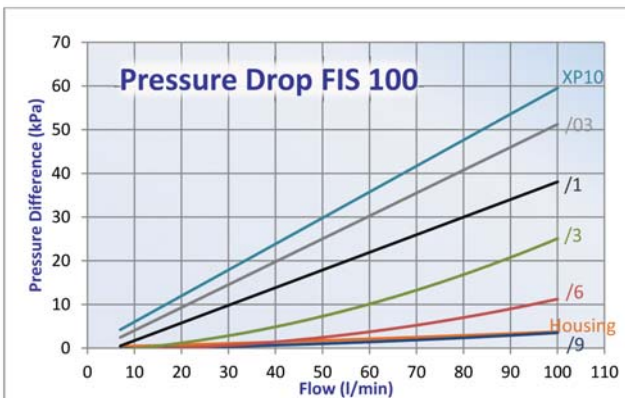
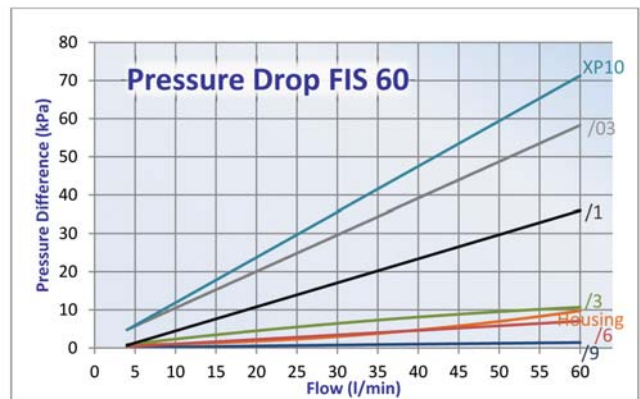
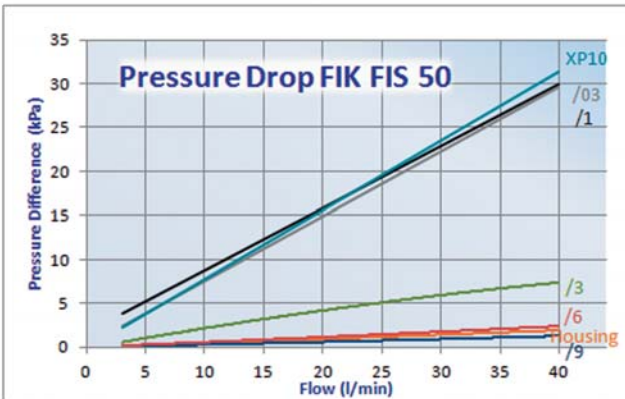
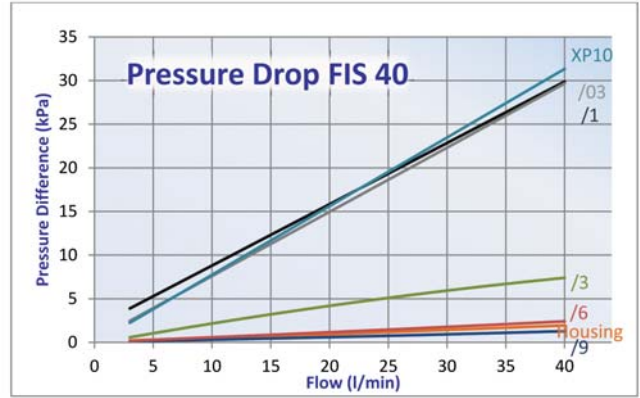
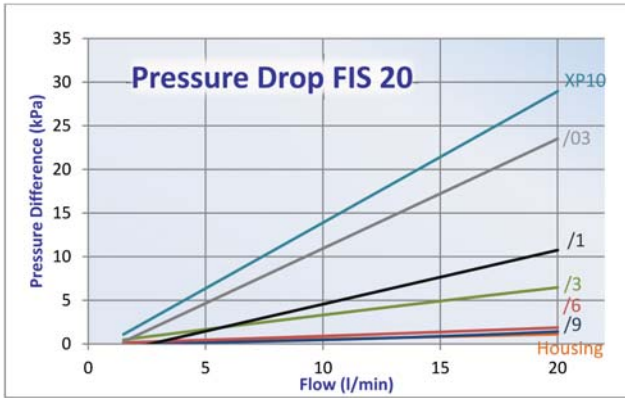

FIK-FIS SRK-Combo 120

Open empty housing
in correct order



Remove carton ring
before use

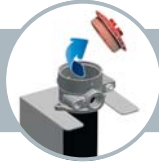

Check if O-ring between
lid and housing is installed and intact

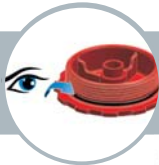

Check if O-Ring on cartridge is installed and
intact



For FIK:
Mount O-ring over stud



For Low Pressure cartridges:
Mount spring on cartridge



Mount element in
housing



For Combo 120:
Align arrows as shown



Assemble lid on housing



Assemble bolts and
screws in correct order



Tighten screws, bolts or lid until thread ends
For spin-ons: hand tighten until contact
between O-ring and head is made; and then
continue by hand as indicated on spin-on



Degrease surface where sparepart sticker
will be mounted
Only for cartridge type filters



Sparepart sticker in each sparepart box



Fix sparepart sticker in area indicated –
Ready!



Do not forget seals



Mix&Match to Get What You Need

Donaldson's Mix&Match system provides the great performance and functional advantages of custom-engineered filters with the convenience and speedy delivery of in-stock parts. Choose your options and build a filter model that exactly suits your cleanliness requirements.

Technical Data

- Operating pressure up to 3000 kPa (30 bar).
- Static pressure testing up to 4500 kPa (45 bar).
- By-pass valve setting 150 kPa (1,5 bar) per ISO 3968.
- Operating temperature -20 +120°C.
- Compatibility with hydraulic fluids per ISO 2943.
- Flow rate and pressure drop per ISO 3968 with oil kinematic viscosity 30 cSt at 40°C and density 0,875 kg/dm³.
- Flange per SAE J518: 3000 PSI.

Filter Elements

- Wire mesh: 60-90 micron.
- Cellulose media: 36-50 micron, reinforced with wire mesh.
- Synteq® synthetic media: 11-23 micron.
- Collapse resistance 1000 kPa (10 bar) per ISO 2941.
- Replacement element includes spring and O-ring seal.

Components



Family	WIRE MESH				CELLULOSE MEDIA				SYNTHETIC MEDIA				CARTRIDGE CODE
	/9		/6		/3		/1		/03		XP10		
	90µm		60µm		$\beta_{50\mu m(e)} \geq 1000$		$\beta_{36\mu m(e)} \geq 1000$		$\beta_{23\mu m(e)} \geq 1000$		$\beta_{11\mu m(e)} \geq 1000$		
	RMF		RMF	RMF		RMF		RMF		RMF			
FLS50	40	P171518	40	P171523	35	P171522	35	P171521	30	P171520	30	P171519	CR50
FLS100	80	P171530	80	P171535	65	P171534	65	P171533	60	P171532	60	P171531	CR100
FLS150	130	P171584	130	P171589	110	P171588	110	P171587	90	P171586	90	P171585	CR125
FLS180	180	P171536	180	P171541	130	P171540	130	P171539	110	P171538	110	P171537	CR180
FLS200	200	P171596	200	P171601	140	P171600	140	P171599	120	P171598	120	P171597	CL200
FLS250	250	P171590	250	P171595	160	P171594	160	P171593	140	P171592	140	P171591	CR220
FLSF250	250	P171590	250	P171595	160	P171594	160	P171593	140	P171592	140	P171591	CR220
FLS330	330	P171560	330	P171565	220	P171564	220	P171563	180	P171562	180	P171561	CR330
FLSF330	330	P171560	330	P171565	220	P171564	220	P171563	180	P171562	180	P171561	CR330
FLS500	500	P171566	500	P171571	400	P171570	400	P171569	350	P171568	350	P171567	CR500
FLSF500	500	P171566	500	P171571	400	P171570	400	P171569	350	P171568	350	P171567	CR500
FLSF800	600	P171578	600	P171583	500	P171582	500	P171581	400	P171580	400	P171579	CR800

RMF = Recommended Maximum Flow in liters/minute with use of standard housing.

BPV = Bypass Valve Setting.

* only FLS200 has the Bypass valve installed in the head, for all other sizes the bypass valve is included in the cartridge.

FLS 50-180

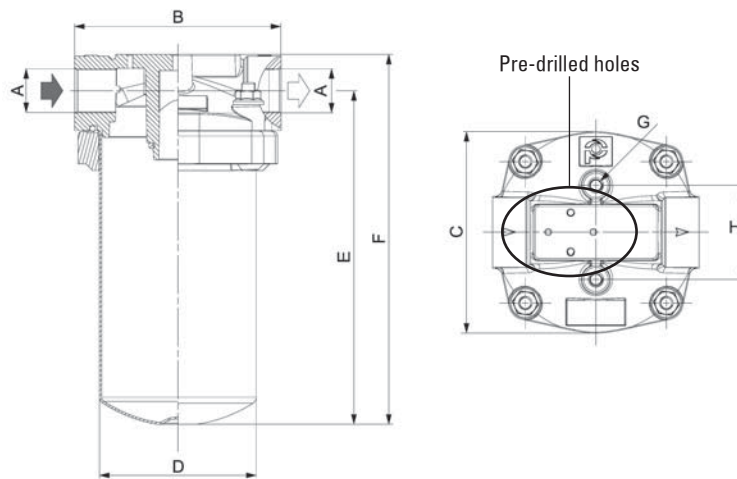

FLS 200

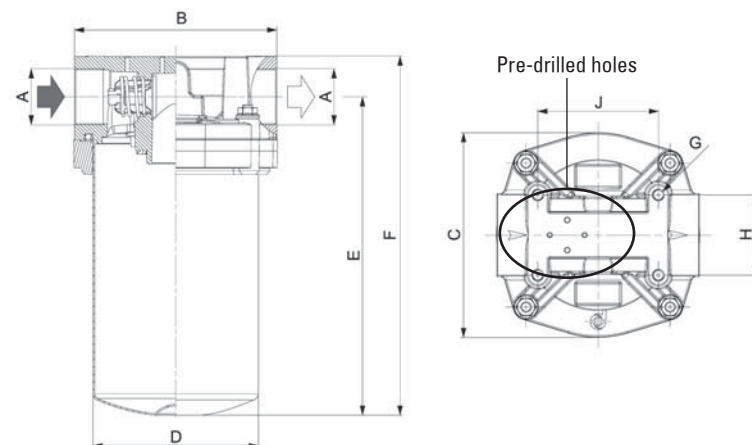



Standard housing with pre-drilled holes without cartridge	Standard housing without pre-drilled holes without cartridge	HOUSING DIMENSIONS														CARTRIDGE DIMENSIONS			POSSIBLE INDICATORS Only applicable if housing is with pre-drilled holes.
		A	B	C	D	E	F	G	H	J	K	L	M	N	BPV	X	Y	Z	
			mm	mm	mm	mm	mm		mm	mm	mm	mm		mm	bar	mm	mm	mm	
P766672	P766995	G1/2	119	116	90	140	161	M8	54	-	-	-	-	-	1,5	75	70	29	P171950 P171961 P171963
P766673	P766996	G3/4	119	116	90	192	213	M8	54	-	-	-	-	-	1,5	128	70	29	
P766671	P766997	G1	140	135	109	246	277	M8	68	-	-	-	-	-	1,5	169	95	41	
P766670	P766998	G1 1/4	140	135	109	284	314	M8	68	-	-	-	-	-	1,5	203	95	41	
P766666	P766999	G1 1/4	151	153	123	238	268	M8	60	90	-	-	-	-	1,5*	180	112	46	
P766667	P767000	G1 1/2	212	208	169	225	269	M8	96	96	-	-	-	-	1,5	136	140	65	
P766663	P767001	Flange 1" 1/2	212	208	169	225	269	M8	96	96	70	36,7	M12	22	1,5	136	140	65	
P766669	P767002	G1 1/2	212	208	169	295	339	M8	96	96	-	-	-	-	1,5	203	140	65	
P766662	P767003	Flange 1" 1/2	212	208	169	295	339	M8	96	96	70	36,7	M12	22	1,5	203	140	65	
P766665	P767004	G2	212	208	169	295	339	M8	96	96	-	-	-	-	1,5	203	140	65	
P766668	P767005	Flange 2"	212	208	169	295	339	M8	96	96	77,8	42,8	M12	22	1,5	203	140	65	
P766664	P767006	Flange 2"	212	208	171	495	539	M8	96	96	77,8	42,8	M12	22	1,5	400	140	65	

If housing with pre-drilled holes selected, you have to install an indicator. Because pre-drilled holes are not plugged.

FLS 250-800

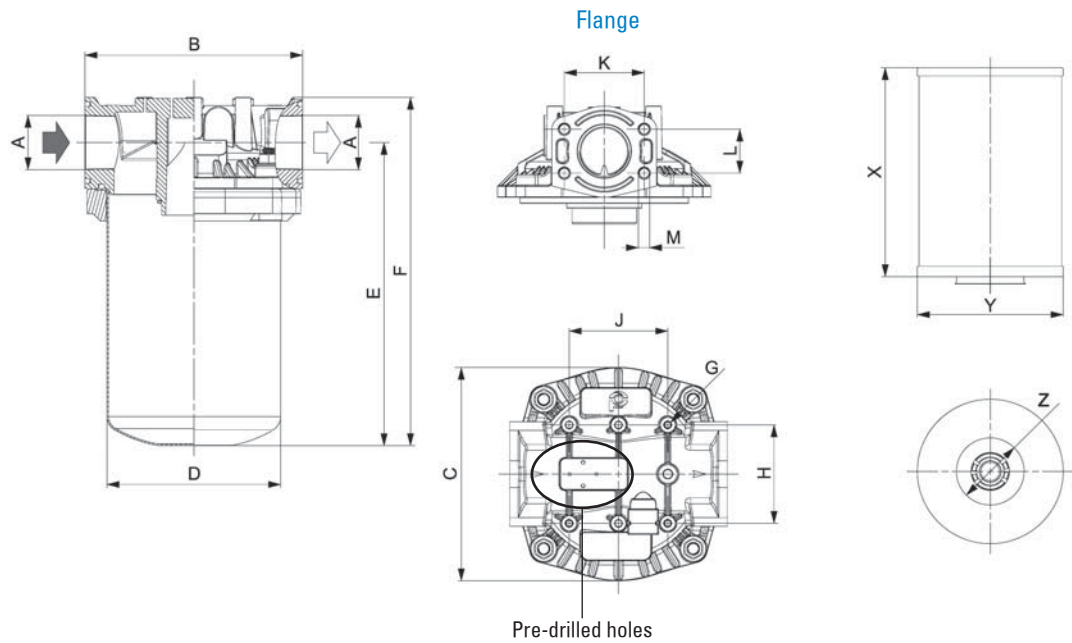

Indicator Choices

Part	Kind		Reference Drawing	Setting (bar)	Contact	Protection Class	Cable Clamp	Max. Values
P171961	Electrical	Differential	A	1,4	Normally Open	IP65	PG11	30 Vcc/Ac; 0,5 A res. and 0,2 A ind.
P171963	Electrical	Differential	A	1,4	Normally Closed	IP65	PG11	30 Vcc/Ac; 0,5 A res. and 0,2 A ind.
P171950	Visual	Differential	E	1,4				

Installation & Service Guidelines

Important

- Oil the O-Rings before assembly.

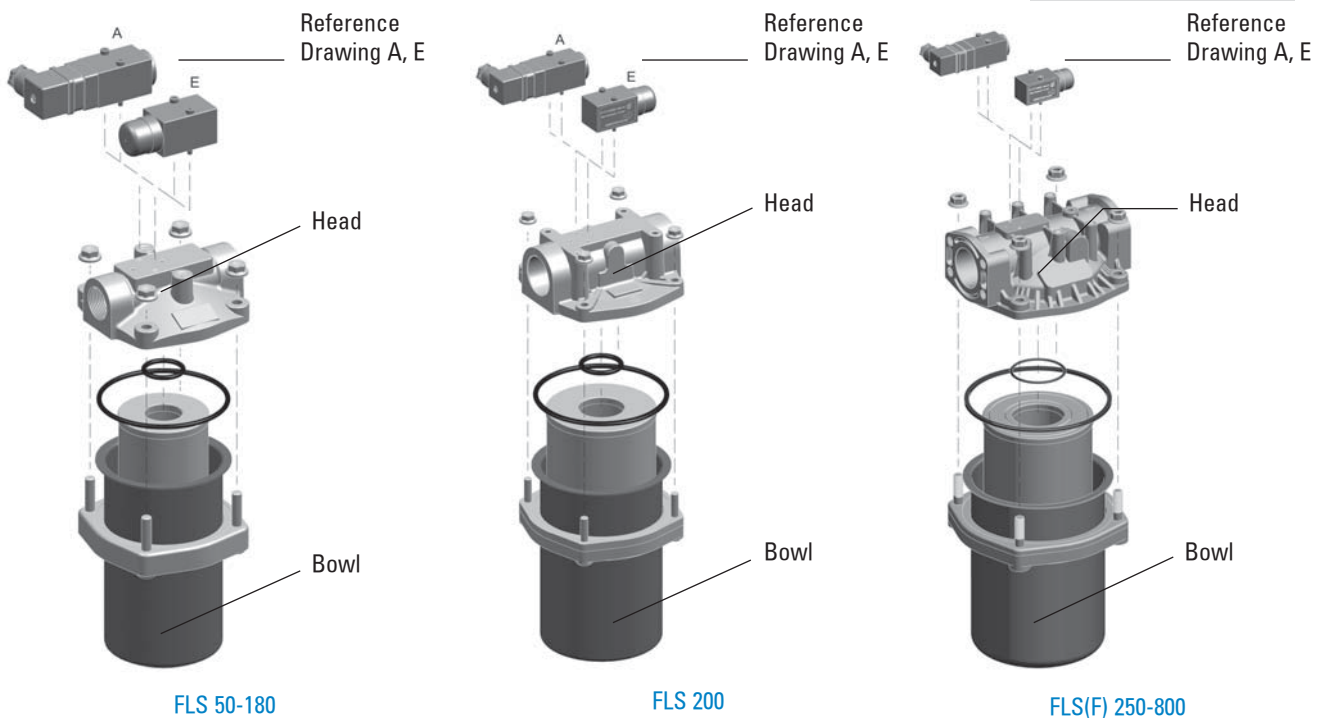

Performance Curves

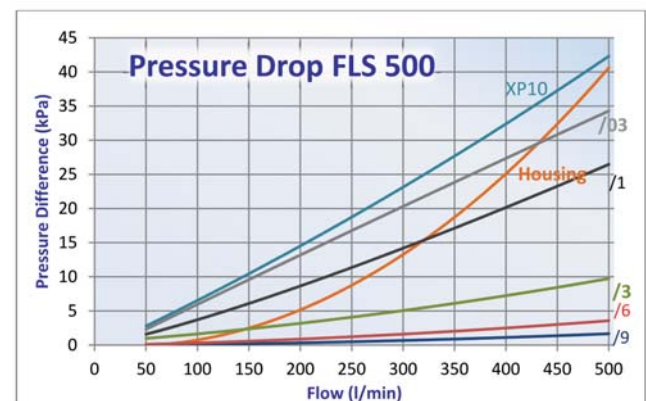
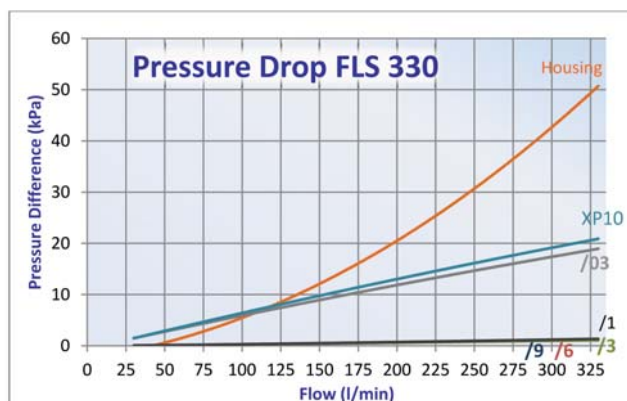
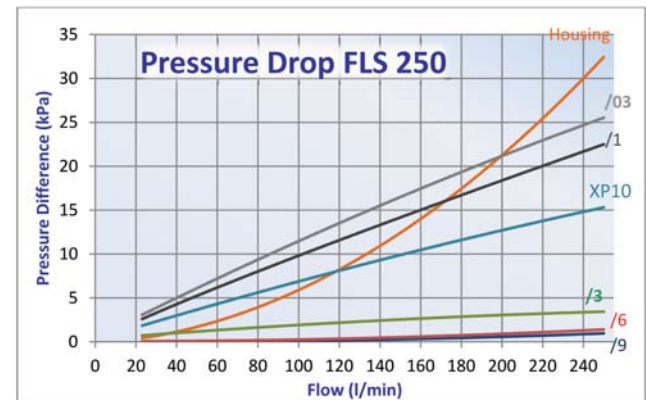
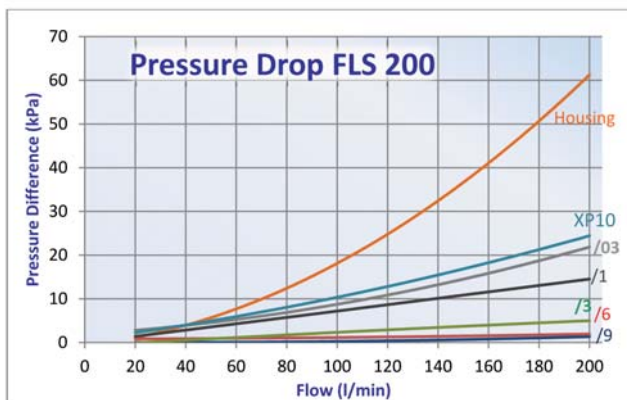
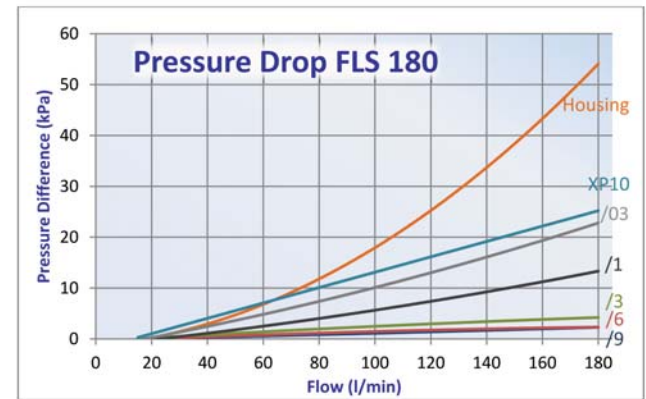
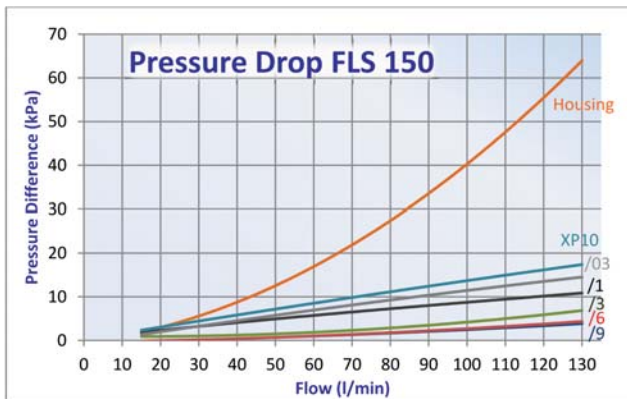
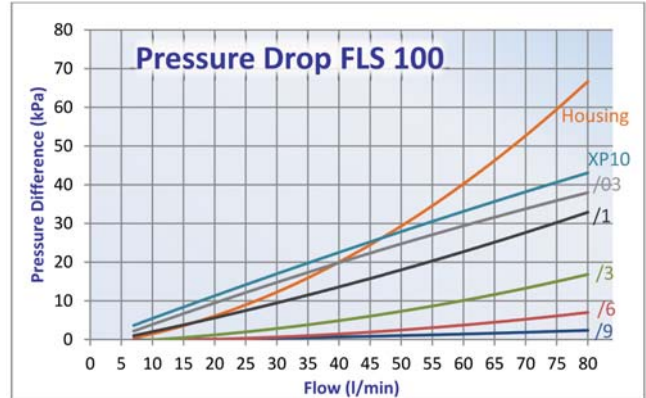
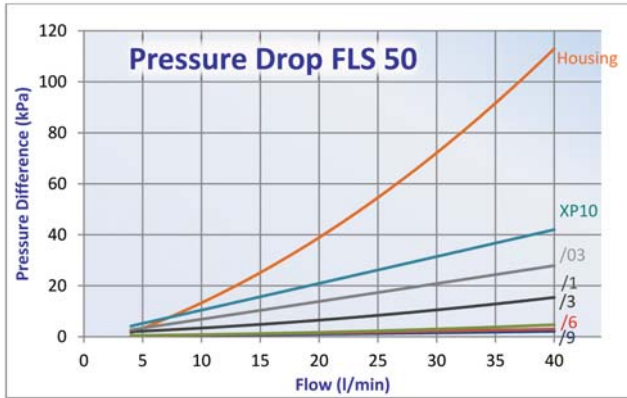

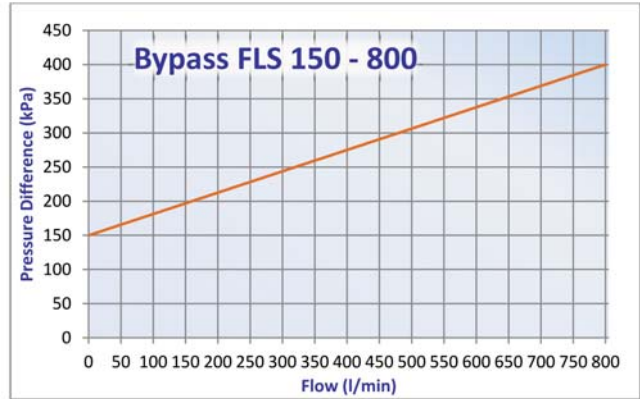
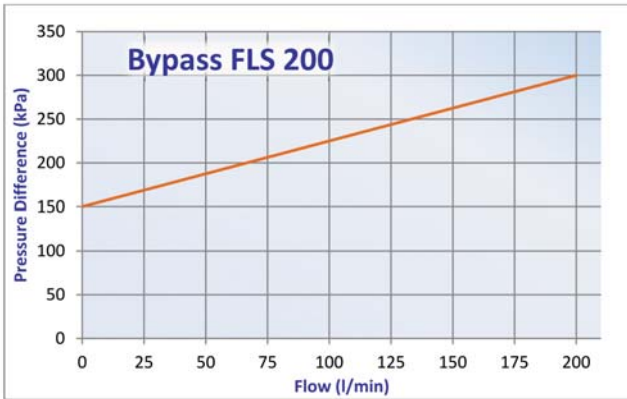
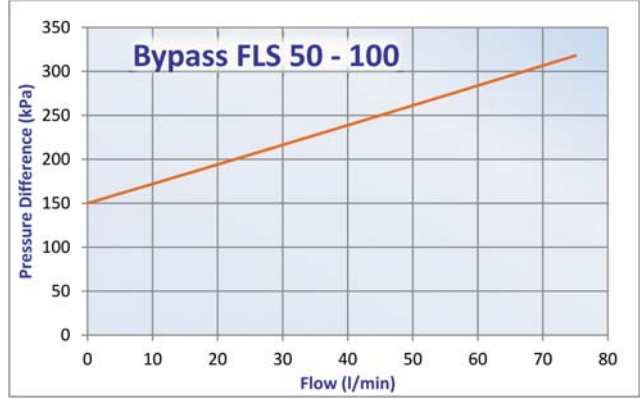
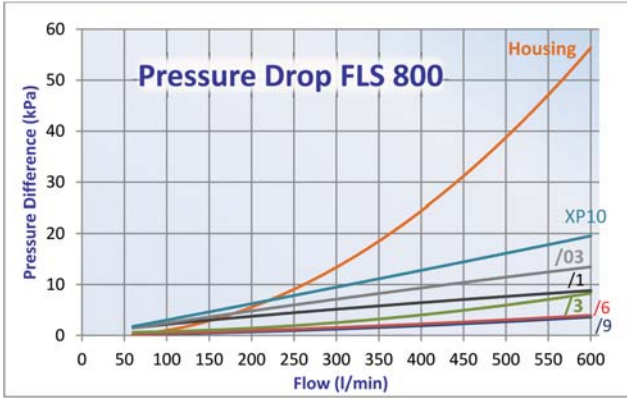



Mix&Match to Get What You Need

Donaldson's Mix&Match system provides the great performance and functional advantages of custom-engineered filters with the convenience and speedy delivery of in-stock parts. Choose your options and build a filter model that exactly suits your cleanliness requirements.

Technical Data

- Operating pressure up to 1000 kPa (10 bar).
- Static pressure testing up to 1500 kPa (15 bar).
- By-pass valve setting 150 kPa (1,5 bar) or 170 kPa (1,7 bar) per ISO 3968.
- Operating temperature -20 +120°C.
- Compatibility with hydraulic fluids per ISO 2943.
- Flow rate and pressure drop determined per ISO 3968 with oil kinematic viscosity 30 cSt at 40°C and density 0,875 kg/dm³.

Filter Elements

- Operating pressure up to 1000 kPa (10 bar).
- Static pressure testing up to 1500 kPa (15 bar).
- Collapse resistance 1000 kPa (10 bar) per ISO 2941.
- Wire mesh: 60 micron.
- Cellulose media: 36-50 micron, reinforced with wire mesh.
- Synteq® synthetic media: 11-23 micron.



Components

Family	WIRE MESH MEDIA		CELLULOSE MEDIA				SYNTHETIC MEDIA				CARTRIDGE CODE
	/6		/3		/1		/03		XP10		
	60µm		β _{50µm(c)} ≥1000		β _{36µm(c)} ≥1000		β _{23µm(c)} ≥1000		β _{11µm(c)} ≥1000		
	RMF		RMF		RMF		RMF		RMF		
FRCA60	60	P171607	60	P171606	50	P550268	40	P171604	40	P171602	CA60
FRCA80	80	P171612	70	P171611	60	P171610	50	P171609	50	P171608	CA80
FRCA108			100	P764638							CA108
FRCA118			100	P763987							CA108
FRCA160	160	P171617	150	P171616	140	P550148	120	P171614	120	P171613	CA160
FRCA200	200	P171622	190	P171621	160	P171620	140	P171619	140	P171618	CA200
FRCA380	380	P171617	340	P171616	300	P550148	280	P171614	280	P171613	CA160
FRCA400	400	P171622	360	P171621	320	P171620	300	P171619	300	P171618	CA200
FRCA220			200	P764410					150	P764411	CA220
FRCA250			230	P764409					170	P763668	CA250

RMF = Recommended Maximum Flow in liters/minute with use of standard head.
BPV = Bypass Valve Setting.

Heads Choices



Head for Size	Part	Ports	Bypass Valve Setting	Indicator Info			Snout	Mounting holes
				Drilled holes for indicator	Side	Indicator to use		
FRCA 60/80	P563279	1 1/16 SAE	1 bar	no	-	none	1-12 UNF	1/4-20 UNC
	P563287	1 1/16 SAE	1 bar	no	-	none	1-12 UNF	M6
	P563280	1 1/16 SAE	1,7 bar	plugged	left + right	P563297, P563298, P563978 or P563296	1-12 UNF	1/4-20 UNC
	P561141	1 1/16 SAE	1,7 bar	no	-	none	1-12 UNF	1/4-20 UNC
	P765539	1 1/16 SAE	2,5 bar	no	-	none	G3/4	M8
	P562261	1/2-14 NPTF	no opening	no	-	none	1-14 UNS	1/4-20 UNC
	P562262	7/8-14 UNF	no opening	no	-	none	1-14 UNS	1/4-20 UNC
	P175017	G3/4	1,7 bar	plugged	left + right	P171954, P171958, P171966 or P173104	G3/4	M8
FRCA 160/200	P173441*	G3/4	1,7 bar	no	-	none	G3/4	M8
	P765584	G3/4	no opening	used	left	P162696 (installed)	G3/4	M8
	P764407	G1 1/4	1,5 bar	plugged	left	P162400 or P163839	G1 1/4	M8
	P761314	G1 1/4	1,5 bar	plugged	top	P171954, P171958, P171966 or P173104	G1 1/4	M8
	P762638	G1 1/4	1,5 bar	plugged	right	P171954, P171958, P171966 or P173104	G1 1/4	M8
	P176846*	G1 1/4	1,5 bar	no	-	none	G1 1/4	M8
	P765583	G1 1/4	no opening	used	left	P162696 (installed)	G1 1/4	M8
	P760071	G1 1/4	1,5 bar	drilled, not plugged	top	P171961, P171963 or P171950	G1 1/4	M8
	P764408	G1 1/4	1,5 bar	drilled, not plugged	left	P162696	G1 1/4	M8
	P762641	G1 1/4	3 bar	no	-	none	G1 1/4	M8
FRCA 220/250	P176965	G1 1/4	no opening	plugged	left + right	-	G1 1/4	M8
	P173403	G1 1/4	no opening	plugged	left + right	P171954, P171958, P171966 or P173104	G1 1/4	M8
	P765639	G1 1/4	no opening	drilled, not plugged	left	P162696	G1 1/4	M8
	P764414	G1 1/4	1,5 bar	drilled, not plugged	left	P162400 or P163839	1 1/2-16 UN	M8
	P764413	G1 1/4	1,5 bar	plugged	top	P171954, P171958, P171966 or P173104	1 1/2-16 UN	M8
	P764412*	G1 1/4	1,5 bar	no	-	none	1 1/2-16 UN	M8
	P764415	G1 1/4	1,5 bar	drilled, not plugged	left	P162696	1 1/2-16 UN	M8
FRCA 380/400	P764421	G1 1/4	no opening	plugged	right	P171954, P171958, P171966 or P173104	1 1/2-16 UN	M8
	P761264	G1 1/2	1,7 bar	drilled, not plugged	front	P171961, P171963 or P171950	G1 1/4	M10
	P766293*	G1 1/2	1,7 bar	no	-	none	G1 1/4	M10

FBK Filters aren't delivered with drilled holes for indicators or bypass valve, heads are.
Unless otherwise mentioned, the usage of indicators is mandatory, because the drilled holes for indicators are not plugged.

* Standard Head



Standard Head	HEAD DIMENSIONS									SPIN-ON DIMENSIONS		
	A	B	C	D	E	F	G	S	BPV	X	Y	Z
		mm	mm	mm		mm	mm	mm	bar	mm	mm	
P173441	G3/4	95	13	41,5	M8	38		20	1,7	146	96	G3/4
NA										209	96	G3/4
										183	108	M40x2
										230	108	M40x2
P176846	G1 1/4	132	28,5	61,5	M8	50		24	1,5	181	128	G1 1/4
P766293	G1 1/2	138	35	70	M10		65	24	1,5	226	128	G1 1/4
										181	128	G1 1/4
P764412	G1 1/4	132	28,5	61,5	M8	50		25	1,5	236	136	1 1/2-16UN
										306	136	1 1/2-16UN

FRCA 60/80

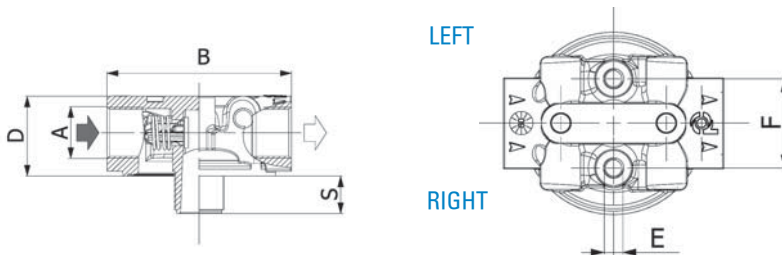

FRCA 160/200

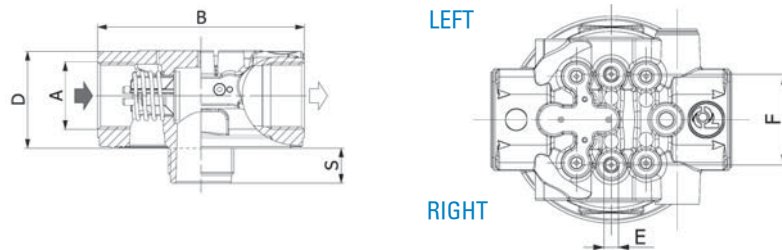

FRCA 220/250

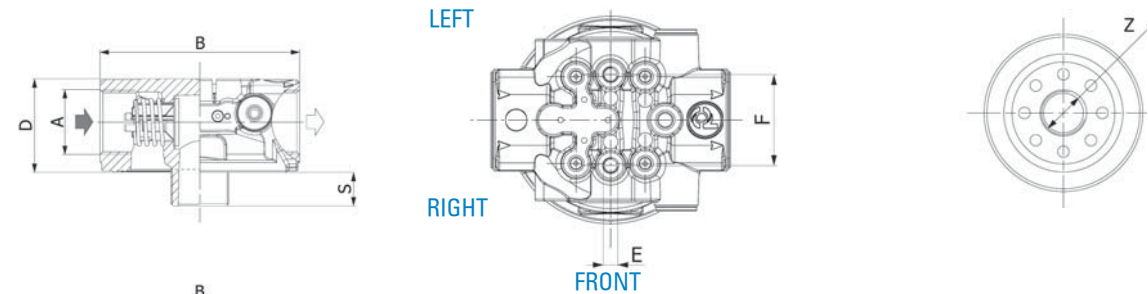

FRCA 380/400

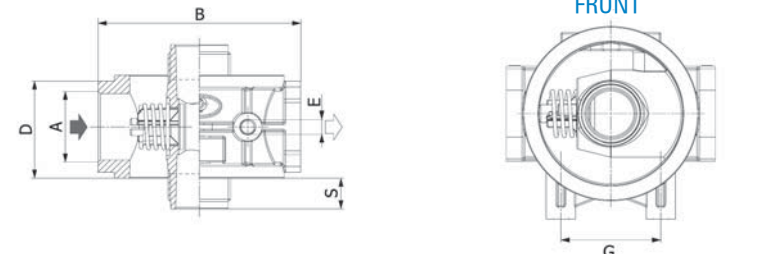

Indicator Choices

Indicator	Kind		Reference Drawing	Setting (bar)	Contact	Protection Class	Cable Clamp	Max. Values
P171961	Electrical	Differential	A	1,4	Normally Open/Closed	IP65	PG11	30 Vcc/Ac; 0,5 A res. and 0,2 A ind.
P171963	Electrical	Differential	A	1,4	Normally Open/Closed	IP65	PG11	30 Vcc/Ac; 0,5 A res. and 0,2 A ind.
P162400	Electrical	Differential	B	1,25	Normally Open			6-30 V DC; 200 mA
P163839	Electrical	Differential	B	1,25	Normally Closed			6-30 V DC; 200 mA
P171966	Electrical	Differential	C	1,2	Normally Open	IP65	PG7	48 V; 0,5 A res. and 0,2 A ind.
P173104	Electrical	Differential	C	1,2	Normally Closed	IP65	PG7	48 V; 0,5 A res. and 0,2 A ind.
P162696	Visual	Differential	D	1,7				
P171950	Visual	Differential	E	1,4				
P171958	Visual	Differential	F	1,2				
P171954	Visual	Vacuum	G	-1/3				

Installation & Service Guidelines

Important

- The filter head snout must be lubricated before spinning on a new filter to prevent thread damage. Heavyweight gear lube is recommended.
- Oil the O-Rings before assembly.

Performance Curves

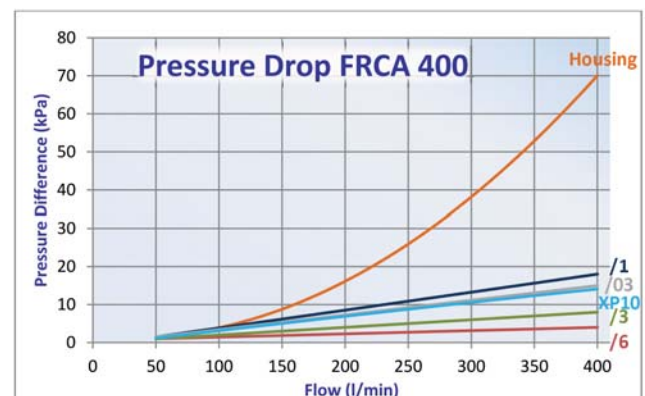
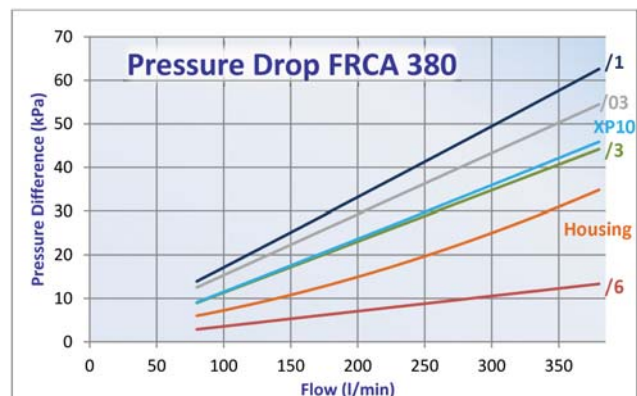
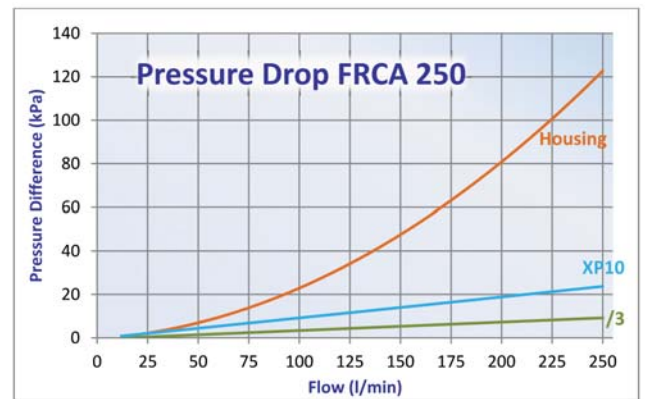
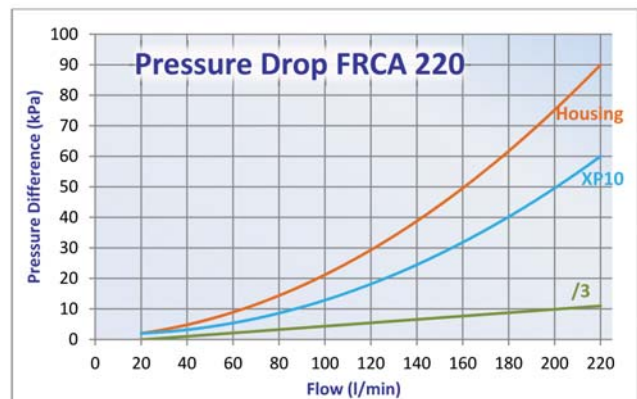
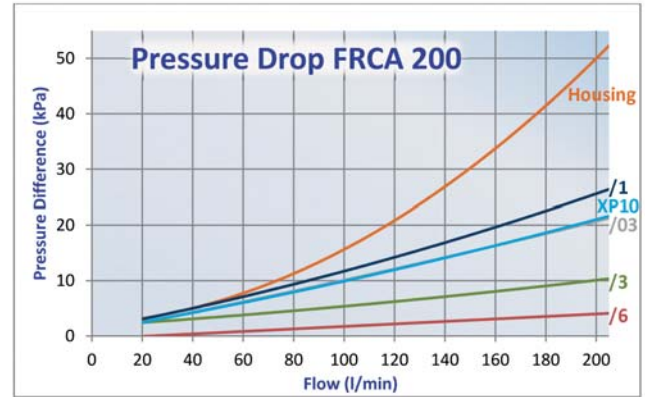
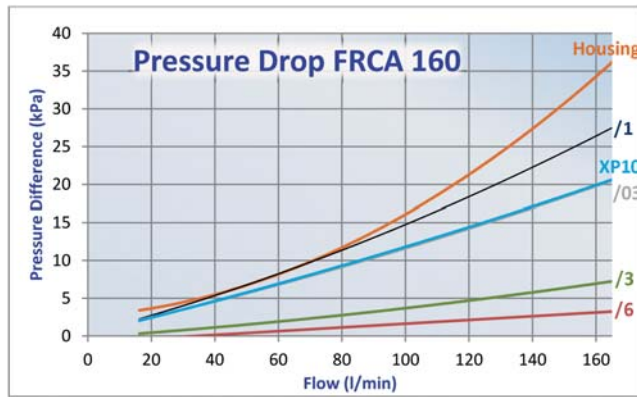
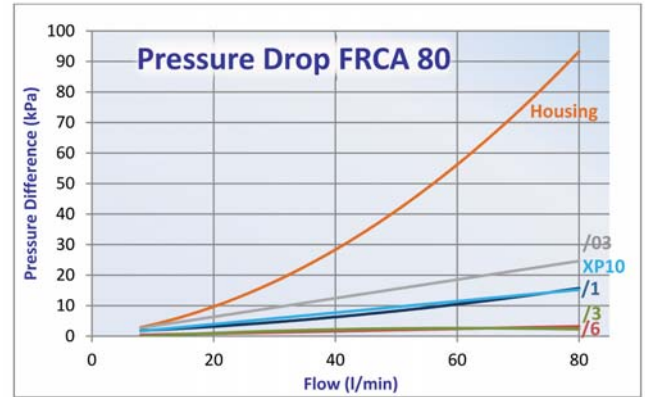
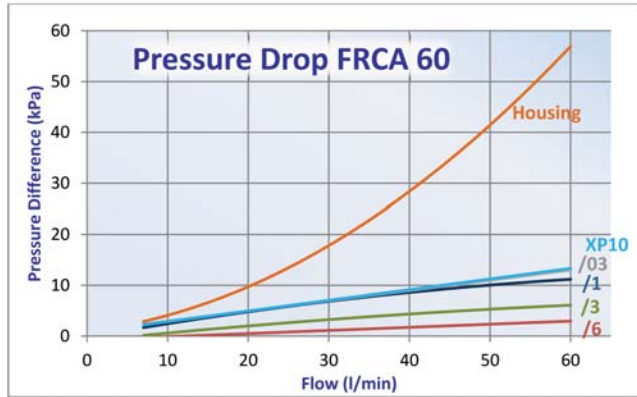

RETURN FILTERS
IN-LINE

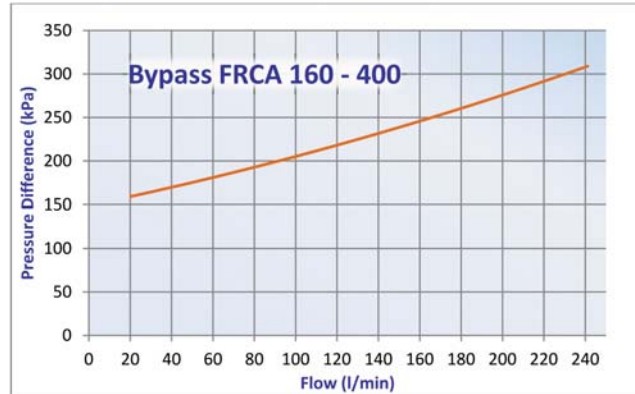
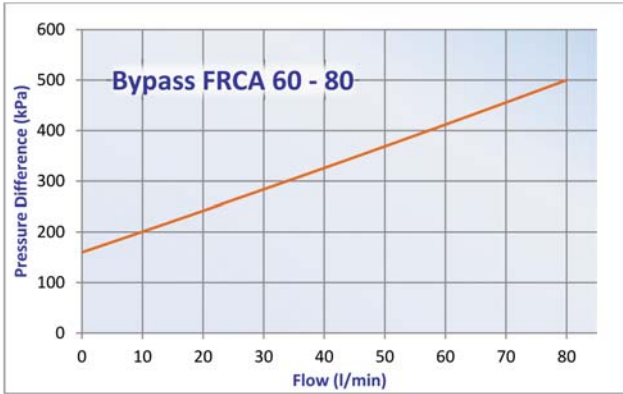



Mix&Match to Get What You Need

Donaldson's Mix&Match system provides the great performance and functional advantages of custom-engineered filters with the convenience and speedy delivery of in-stock parts. Choose your options and build a filter model that exactly suits your cleanliness requirements.

Technical Data

- Operating pressure up to 1000 kPa (10 bar).
- Static pressure testing up to 1500 kPa (15 bar).
- By pass valve setting 150 kPa (1,5 bar) per ISO 3968.
- Operating temperature -20 +120°C.
- Compatibility with hydraulic fluids per ISO 2943.
- Flow rate and pressure drop determined per ISO 3968 with oil kinematic viscosity 30 cSt at 40°C and density 0,875 kg/dm³.

Filter Elements

- Wire mesh: 60-90 micron.
- Cellulose media: 36-50 micron, reinforced with wire mesh.
- Synteq® synthetic media: 11-23 micron.
- Collapse resistance 1000 kPa (10 bar) per ISO 2941.
- Replacement element includes spring and O-ring seal.

Components



RETURN & SUCTION FILTERS IN-TANK

Family	WIRE MESH						CELLULOSE MEDIA						SYNTHETIC MEDIA						CARTRIDGE CODE
	/9			/6			/3			/1			/03			XP10			
	90µm			60µm			$\beta_{90\mu m(c)} \geq 1000$			$\beta_{36\mu m(c)} \geq 1000$			$\beta_{23\mu m(c)} \geq 1000$			$\beta_{11\mu m(c)} \geq 1000$			
RMF Return	RMF Suction		RMF Return	RMF Suction		RMF Return	RMF Suction		RMF Return	RMF Suction		RMF Return	RMF Suction		RMF Return	RMF Suction			
FIR 30	30	15	P171500	30	15	P171505	20	10	P171504	20	10	P171503	15	8	P171502	15	8	P171501	CR30
FIR 60	60	30	P171524	60	30	P171529	40	20	P171528	40	20	P171527	35	15	P171526	35	15	P171525	CR60
FIR 100	100	50	P171530	100	50	P171535	65	35	P171534	65	35	P171533	60	30	P171532	60	30	P171531	CR100
FIR 180	180	90	P171536	180	90	P171541	120	60	P171540	120	60	P171539	110	55	P171538	110	55	P171537	CR180
FIR 500	500	250	P171566	500	250	P171571	400	200	P171570	400	200	P171569	350	180	P171568	350	180	P171567	CR500

RMF = Recommended Maximum Flow in liters/minute with use of standard head.
Standard head is with predrilled holes for indicator, but plugged.

Indicator Choices

Part	Kind		Reference Drawing	Setting (bar)	Contact	Protection Class	Cable Clamp	Max. Values
P171953	Visual	Vacuum	G	-1/5				
P171958	Visual	Differential	F	1,2				
P171966	Electrical	Differential	C	1,2	Normally Open	IP65	PG7	48 V; 0,5 A res. and 0,2 A ind.
P173104	Electrical	Differential	C	1,2	Normally Closed	IP65	PG7	48 V; 0,5 A res. and 0,2 A ind.

Use indicators only on return line applications!



Standard Housing without Cartridge	DIMENSIONS HOUSING											DIMENSIONS ELEMENT			POSSIBLE INDICATOR
	A	B	C	D	E	F	G	J	L	M	N	X	Y	Z	
		mm	mm	mm	mm	mm	mm	mm	mm	mm	predrilled holes	plugged	mm	mm	
P766679	G1/2	88	61	130	7	100	10	40	48	G1/8	YES	52	67	26	P171953 P171958 P171966 P173104
P766481	G3/4	110	67,5	155	9	126	14,5	52	58	G1/8	YES	70	82	29	
P766482	G1	110	109,5	199	9	126	14,5	56	59	G1/8	YES	70	128	29	
P766678	G1 1/4	156	176	288	9	175	16	64	83	G1/8	YES	95	203	41	
P766483	G2	204	167	297,5	9	220	20	77,5	107	G1/8	YES	140	203	65	

RETURN & SUCTION
FILTERS IN-TANK

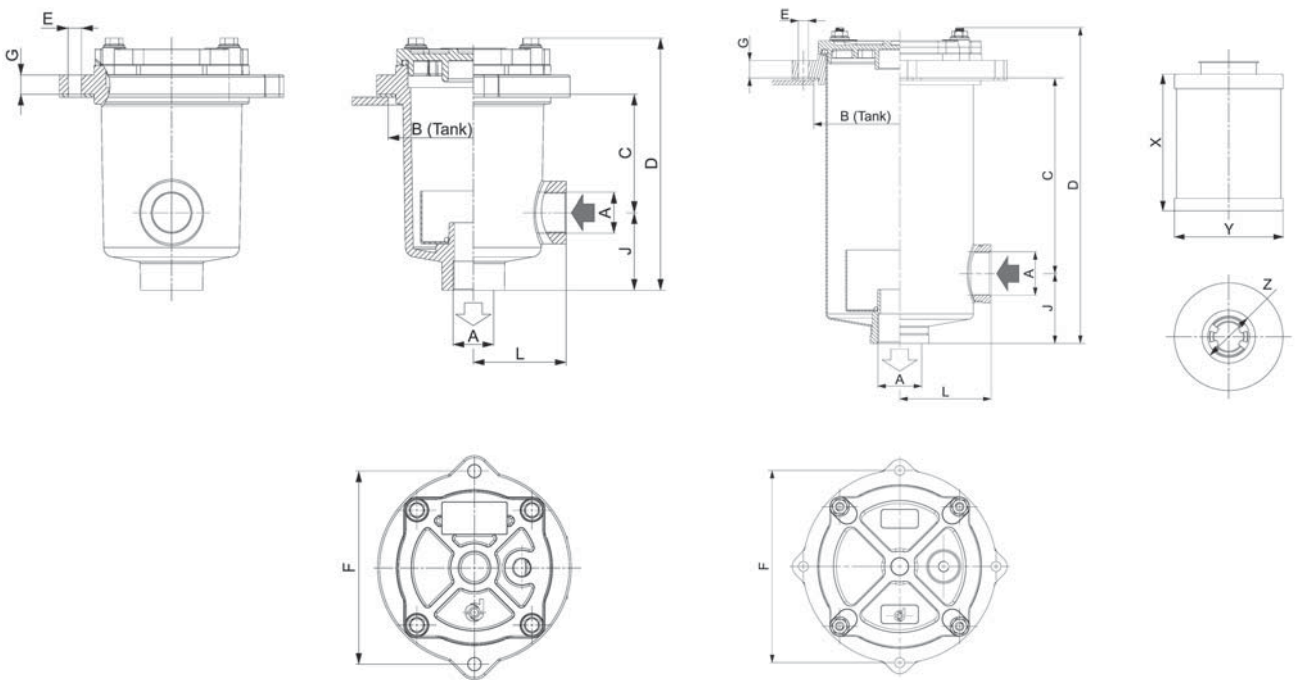

Size 30-100

Size 180-500

Installation & Service Guidelines

RETURN & SUCTION FILTERS IN-TANK

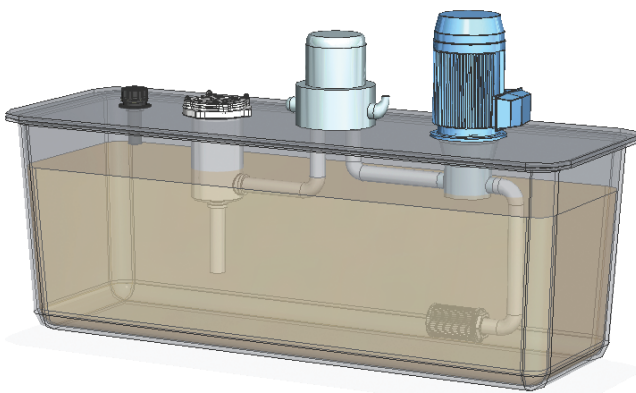
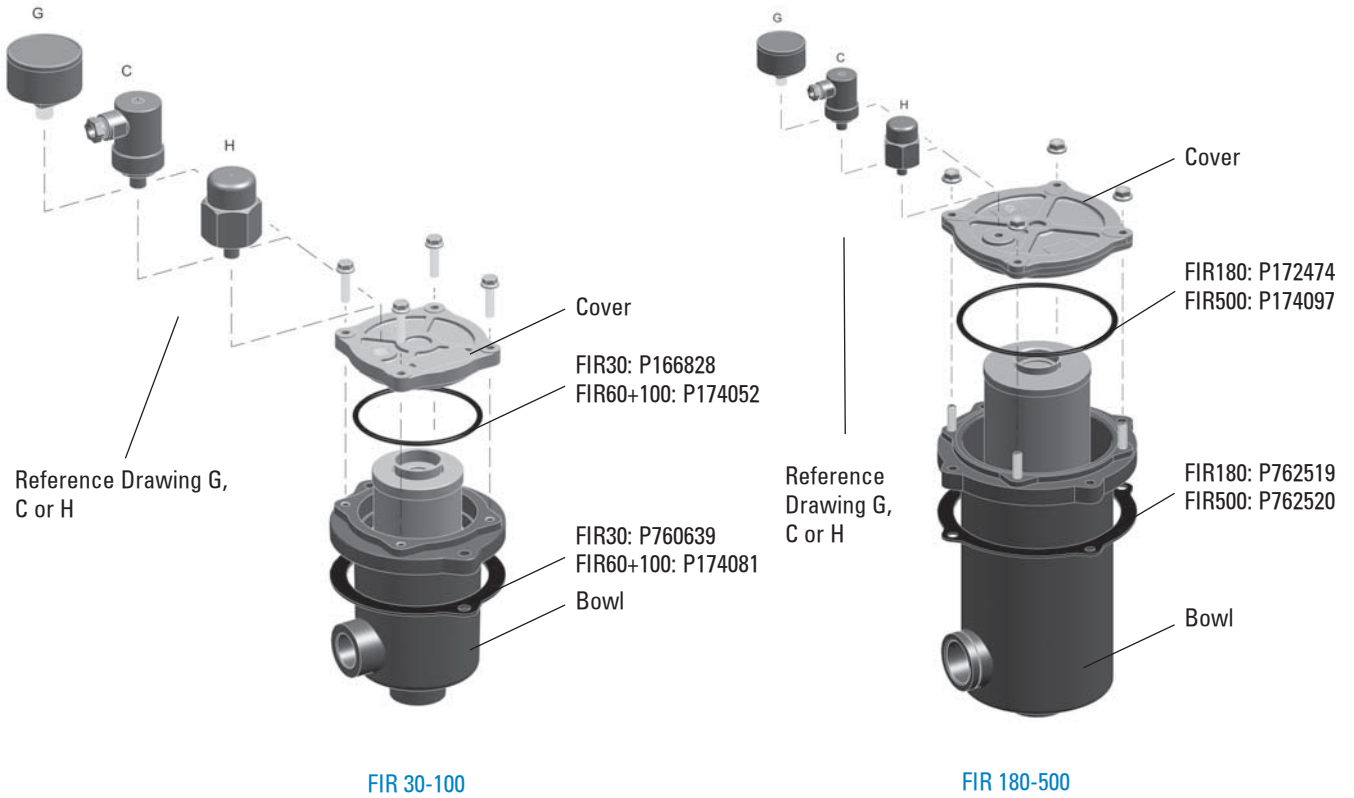

Example of how the filter is mounted in a return flow.

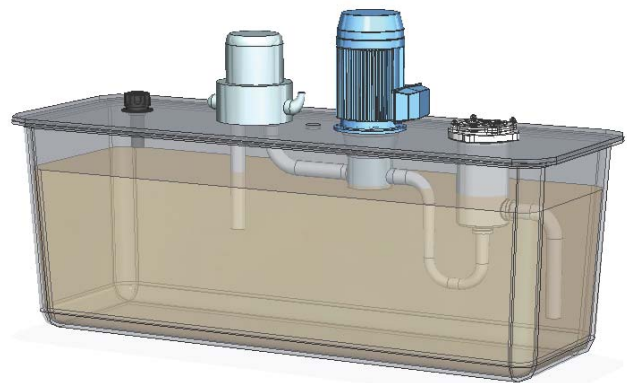

Example of how the filter is mounted in a suction flow.

Performance Curves

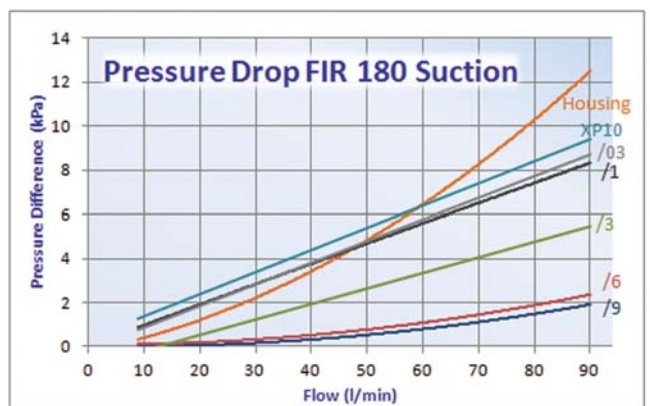
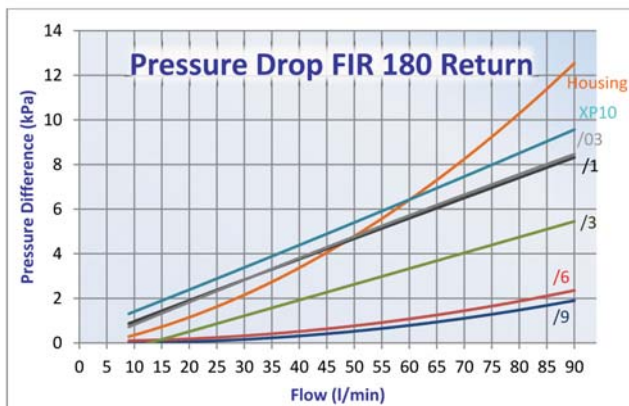
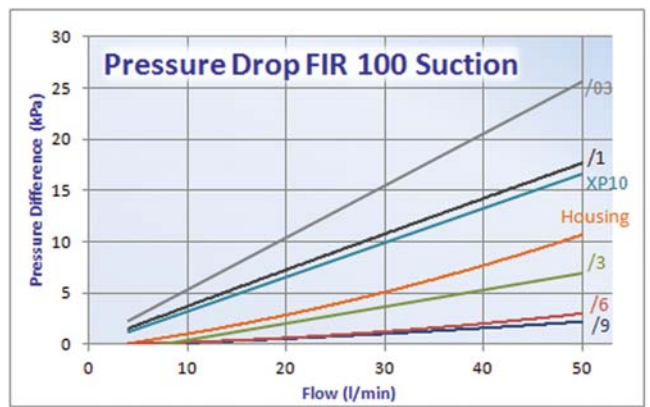
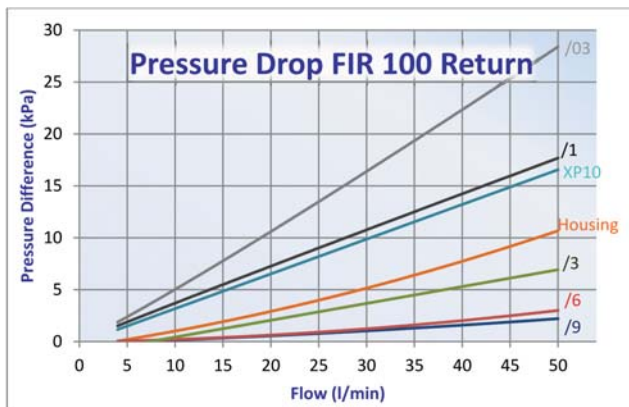
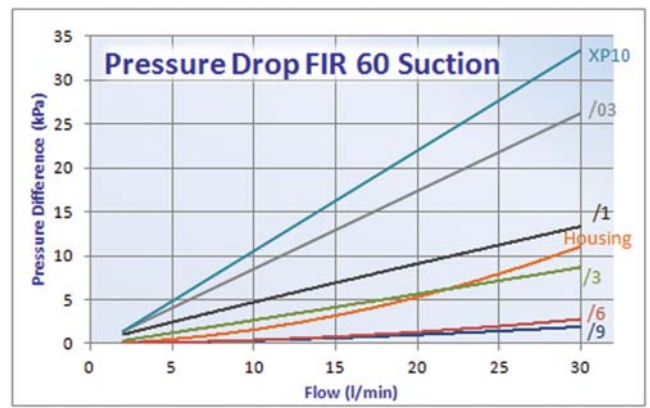
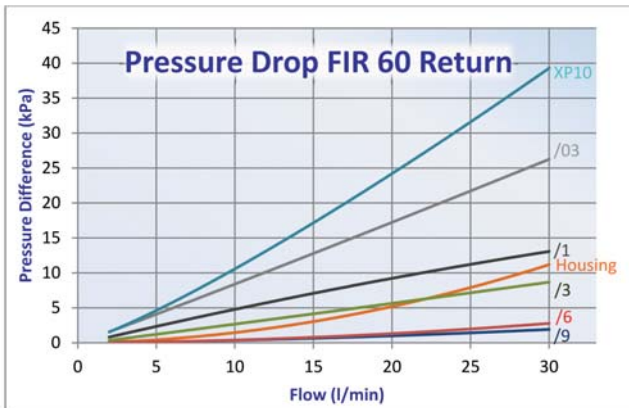
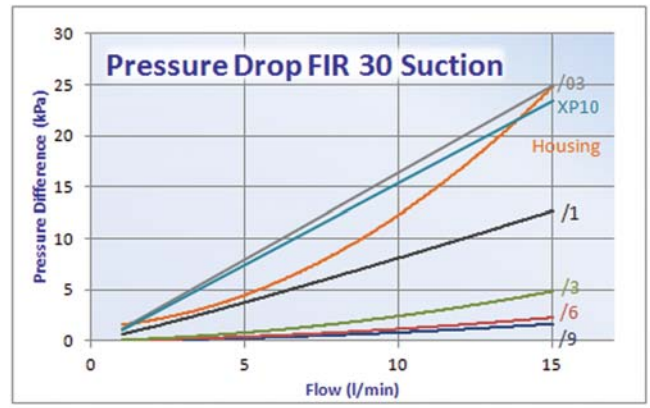
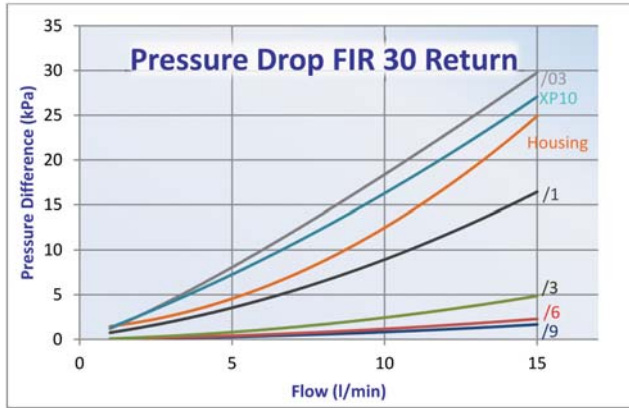

RETURN & SUCTION
FILTERS IN-TANK

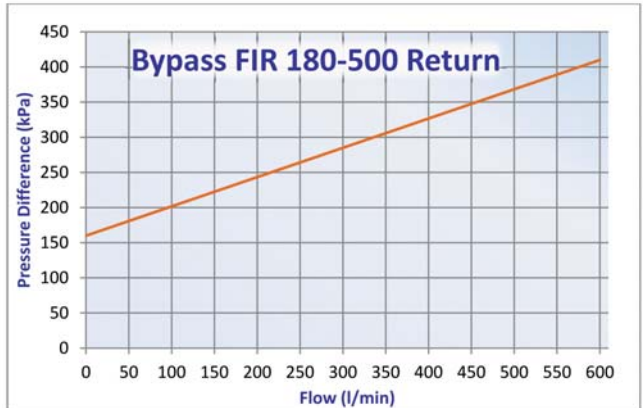
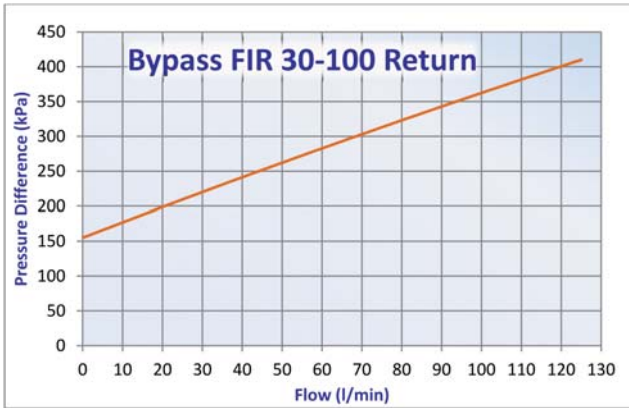
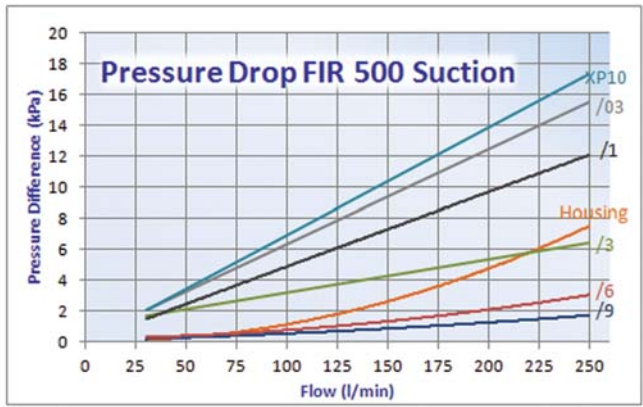
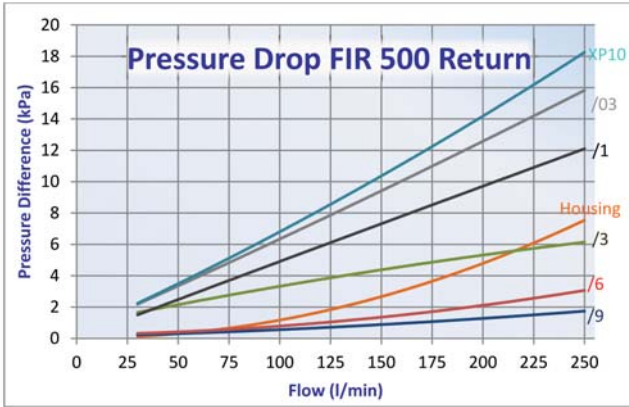



Technical Data

- Operating pressure up to 1000 kPa (10 bar).
- Static pressure testing up to 1500 kPa (15 bar).
- Back pressure valve setting: 0,5 bar per ISO 3968.
- By-pass valve setting: 2,5 bar per ISO 3968.
- Operating temperature -20 +120°C.
- Compatibility with hydraulic fluids per ISO 2943.
- Flow rate and pressure drop determined per ISO 3968 with oil kinematic viscosity 30 cSt at 40°C and density 0,875kg/dm³.

Filter Elements Main

- Synthetic media.
- Filtration efficiency according to ISO 16889:
 $\beta_{11\mu\text{(c)}}=200$, $\beta_{13\mu\text{(c)}}=1000$.
- Unique interface with filter assembly.
- By-pass strainer integrated into the main element 125 micron wire mesh.
- Collapse resistance 1000 kPa (10 bar) per ISO 2941.
- Replacement element includes spring and O-ring seal.

Filter Elements Emergency Suction

- Emergency filtered suction from the tank (125 μm).
- By-pass filtered and pressurized.

Components

RETURN & SUCTION
FILTERS IN-TANK

Family	Style 1	Style 2	Style 3	Main Element		Suction Element							
				Synthetic Media		Wire Mesh							
				$\beta_{10}(\mu\text{m}) \geq 1000$		125 μm							
				RMF		RMF							
COMBO 120	with Emergency suction	Ports on same axis**			120	P763652	60	P763643					
		Ports on same side											
	without Emergency suction*	Ports on same axis**								120	P762421	-	Not applicable
		Ports on same side											
COMBO 200	with Emergency suction	Without extra inlet	no predrilled holes	200	P764198	70	P764183						
			predrilled holes a1										
			predrilled holes a2										
		predrilled holes b											
		With extra inlet G1	no predrilled holes										
			predrilled holes a1										
	predrilled holes a2												
	without Emergency suction*	Without extra inlet	no predrilled holes					200	P764198	-	Not applicable		
			predrilled holes a1										
			predrilled holes a2										
		predrilled holes b											
		With extra inlet G1	no predrilled holes										
predrilled holes a1													
predrilled holes a2													
COMBO 300	with Emergency suction	Without extra inlet	no predrilled holes	300	P765457	70	P764183						
			predrilled holes a1										
			predrilled holes a2										
		predrilled holes b											
		With extra inlet G1	no predrilled holes										
			predrilled holes a1										
	predrilled holes a2												
	without Emergency suction*	Without extra inlet	no predrilled holes					300	P765457	-	Not applicable		
			predrilled holes a1										
			predrilled holes a2										
		predrilled holes b											
		With extra inlet G1	no predrilled holes										
predrilled holes a1													
predrilled holes a2													

* use the option of no emergency suction only if the returning flow rate is always bigger than the suction flow rate

** Additional inlet port G3/8 available on request

NA = Not Applicable

BPV= Bypass Valve Setting



Complete Filters (including Elements)	HOUSING DIMENSIONS																CARTRIDGE DIMENSIONS			POSSIBLE INDICATORS	
	A1	A2	B	C	D	E	F	G	H	I	J	K	L	BPV	Back Pressure Valve	M	N	X	Y		Z
			mm	mm	mm	mm	mm	mm	mm	mm	mm	mm	mm	mm	bar	bar	predilled holes	plugged or indicator	mm		mm
K041511	G1	G3/4	80	308	414	11	115	11	68	68	32	32	72	2,5	0,5	9/16-18 UNF	P165194	91	265	45	P165194, P167455, P173893
K041595	G1	G3/4	80	308	414	11	115	11	90	69	30,3	42,3	72	2,5	0,5	9/16-18 UNF	P165194				P165194, P167455, P173893
K041301	G1	G3/4	80	227	333,5	11	115	11	68	68	32	32	NA	2,5	0,5	9/16-18 UNF	P165194	91	233	36	P165194, P167455, P173893
K041610	G1	G3/4	80	227	333,5	11	115	11	90	69	30,3	42,3	NA	2,5	0,5	9/16-18 UNF	P165194				P165194, P167455, P173893
K041535	G1 1/4	2x G1	100	375	505	11	81/94	13	94,5	86	35	63	50	2,5	0,5	NA	NA				none
K041598	G1 1/4	2x G1	100	375	505	11	81/94	13	94,5	86	35	63	50	2,5	0,5	G1/8	YES				P764431, P764613, P764612
K041602	G1 1/4	2x G1	100	375	505	11	81/94	13	94,5	86	35	63	50	2,5	0,5	G1/8	YES				P764431, P764613, P764612
K041606	G1 1/4	2x G1	100	375	505	11	81/94	13	94,5	86	35	63	50	2,5	0,5	G1/8	YES				P171954
K041596	G1 1/4 + G1	2x G1	100	375	505	11	81/94	13	94,5 / 85,5	86	35	63	50	2,5	0,5	NA	NA				none
K041599	G1 1/4 + G1	2x G1	100	375	505	11	81/94	13	94,5 / 85,5	86	35	63	50	2,5	0,5	G1/8	YES				P764431, P764613, P764612
K041603	G1 1/4 + G1	2x G1	100	375	505	11	81/94	13	94,5 / 85,5	86	35	63	50	2,5	0,5	G1/8	YES				P764431, P764613, P764612
K041607	G1 1/4 + G1	2x G1	100	375	505	11	81/94	13	94,5 / 85,5	86	35	63	50	2,5	0,5	G1/8	YES				P171954
K041528	G1 1/4	2x G1	100	375	505	11	81/94	13	94,5	86	35	63	NA	2,5	0,5	NA	NA	88	361	42	none
K041600	G1 1/4	2x G1	100	375	505	11	81/94	13	94,5	86	35	63	NA	2,5	0,5	G1/8	YES				P764431, P764613, P764612
K041604	G1 1/4	2x G1	100	375	505	11	81/94	13	94,5	86	35	63	NA	2,5	0,5	G1/8	YES				P764431, P764613, P764612
K041608	G1 1/4	2x G1	100	375	505	11	81/94	13	94,5	86	35	63	NA	2,5	0,5	G1/8	YES				P171954
K041597	G1 1/4 + G1	2x G1	100	375	505	11	81/94	13	94,5 / 85,5	86	35	63	NA	2,5	0,5	NA	NA				none
K041601	G1 1/4 + G1	2x G1	100	375	505	11	81/94	13	94,5 / 85,5	86	35	63	NA	2,5	0,5	G1/8	YES				P764431, P764613, P764612
K041605	G1 1/4 + G1	2x G1	100	375	505	11	81/94	13	94,5 / 85,5	86	35	63	NA	2,5	0,5	G1/8	YES				P764431, P764613, P764612
K041609	G1 1/4 + G1	2x G1	100	375	505	11	81/94	13	94,5 / 85,5	86	35	63	NA	2,5	0,5	G1/8	YES				P171954
K041674	G1 1/4	2x G1	100	445	575	11	81/94	13	94,5	86	35	63	50	2,5	0,5	NA	NA				none
K041659	G1 1/4	2x G1	100	445	575	11	81/94	13	94,5	86	35	63	50	2,5	0,5	G1/8	YES				P764431, P764613, P764612
K041660	G1 1/4	2x G1	100	445	575	11	81/94	13	94,5	86	35	63	50	2,5	0,5	G1/8	YES				P764431, P764613, P764612
K041661	G1 1/4	2x G1	100	445	575	11	81/94	13	94,5	86	35	63	50	2,5	0,5	G1/8	YES				P171954
K041662	G1 1/4 + G1	2x G1	100	445	575	11	81/94	13	94,5 / 85,5	86	35	63	50	2,5	0,5	NA	NA				none
K041663	G1 1/4 + G1	2x G1	100	445	575	11	81/94	13	94,5 / 85,5	86	35	63	50	2,5	0,5	G1/8	YES				P764431, P764613, P764612
K041664	G1 1/4 + G1	2x G1	100	445	575	11	81/94	13	94,5 / 85,5	86	35	63	50	2,5	0,5	G1/8	YES				P764431, P764613, P764612
K041665	G1 1/4 + G1	2x G1	100	445	575	11	81/94	13	94,5 / 85,5	86	35	63	50	2,5	0,5	G1/8	YES				P171954
K041666	G1 1/4	2x G1	100	445	575	11	81/94	13	94,5	86	35	63	NA	2,5	0,5	NA	NA	88	431	42	none
K041667	G1 1/4	2x G1	100	445	575	11	81/94	13	94,5	86	35	63	NA	2,5	0,5	G1/8	YES				P764431, P764613, P764612
K041668	G1 1/4	2x G1	100	445	575	11	81/94	13	94,5	86	35	63	NA	2,5	0,5	G1/8	YES				P764431, P764613, P764612
K041669	G1 1/4	2x G1	100	445	575	11	81/94	13	94,5	86	35	63	NA	2,5	0,5	G1/8	YES				P171954
K041670	G1 1/4 + G1	2x G1	100	445	575	11	81/94	13	94,5 / 85,5	86	35	63	NA	2,5	0,5	NA	NA				none
K041671	G1 1/4 + G1	2x G1	100	445	575	11	81/94	13	94,5 / 85,5	86	35	63	NA	2,5	0,5	G1/8	YES				P764431, P764613, P764612
K041672	G1 1/4 + G1	2x G1	100	445	575	11	81/94	13	94,5 / 85,5	86	35	63	NA	2,5	0,5	G1/8	YES				P764431, P764613, P764612
K041673	G1 1/4 + G1	2x G1	100	445	575	11	81/94	13	94,5 / 85,5	86	35	63	NA	2,5	0,5	G1/8	YES				P171954

Stock item (check e-commerce for availability)

RETURN & SUCTION
FILTERS IN-TANK

Indicator Choices

RETURN & SUCTION
FILTERS IN-TANK

Part	Kind		Reference Drawing	Setting (bar)	Contact	Protection Class	Cable Clamp	Max. Values
P171954	Visual	Vacuum	G	-1/3				
P764612	Visual	Differential	F	2,5				max 30 DCV; 0,5 A res. and 0,2 A ind.
P764431	Electrical	Differential	C	2,5	Normally Open	IP65	PG7	max 30 DCV; 0,5 A res. and 0,2 A ind.
P764613	Electrical	Differential	C	2,5	Normally Closed	IP65	PG7	max 30 DCV; 0,5 A res. and 0,2 A ind.
P165194	Electrical	Differential	B	2,76	Normally Open			30 V DC; 0,2A
P167580	Visual	Differential	D	3,4				

Combo 120

Ports on same Side

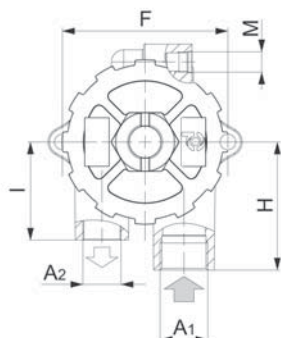
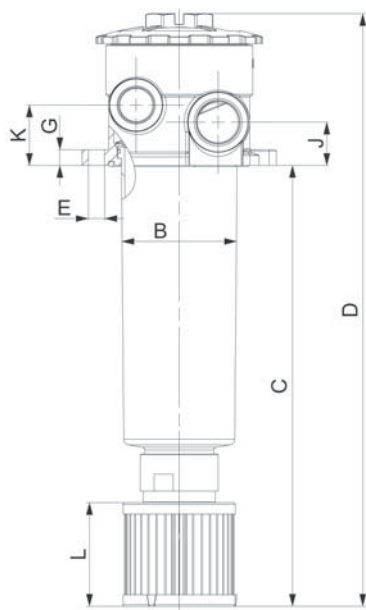

Ports on same Axis

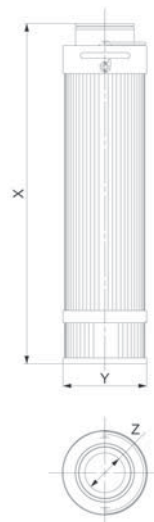
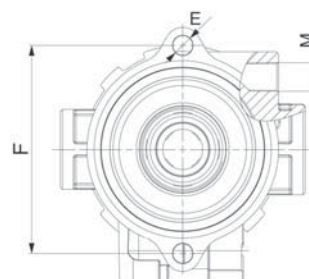
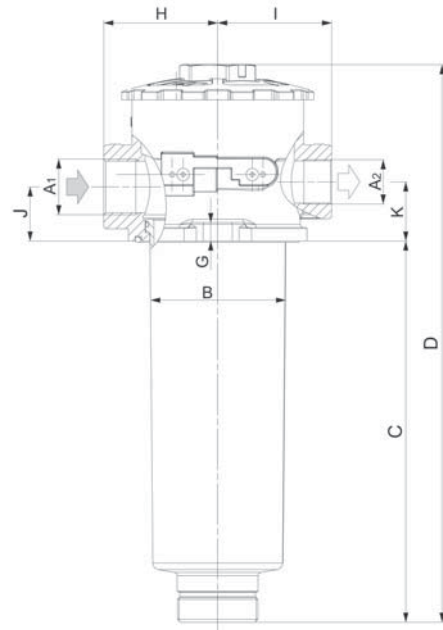

Combo 200/300

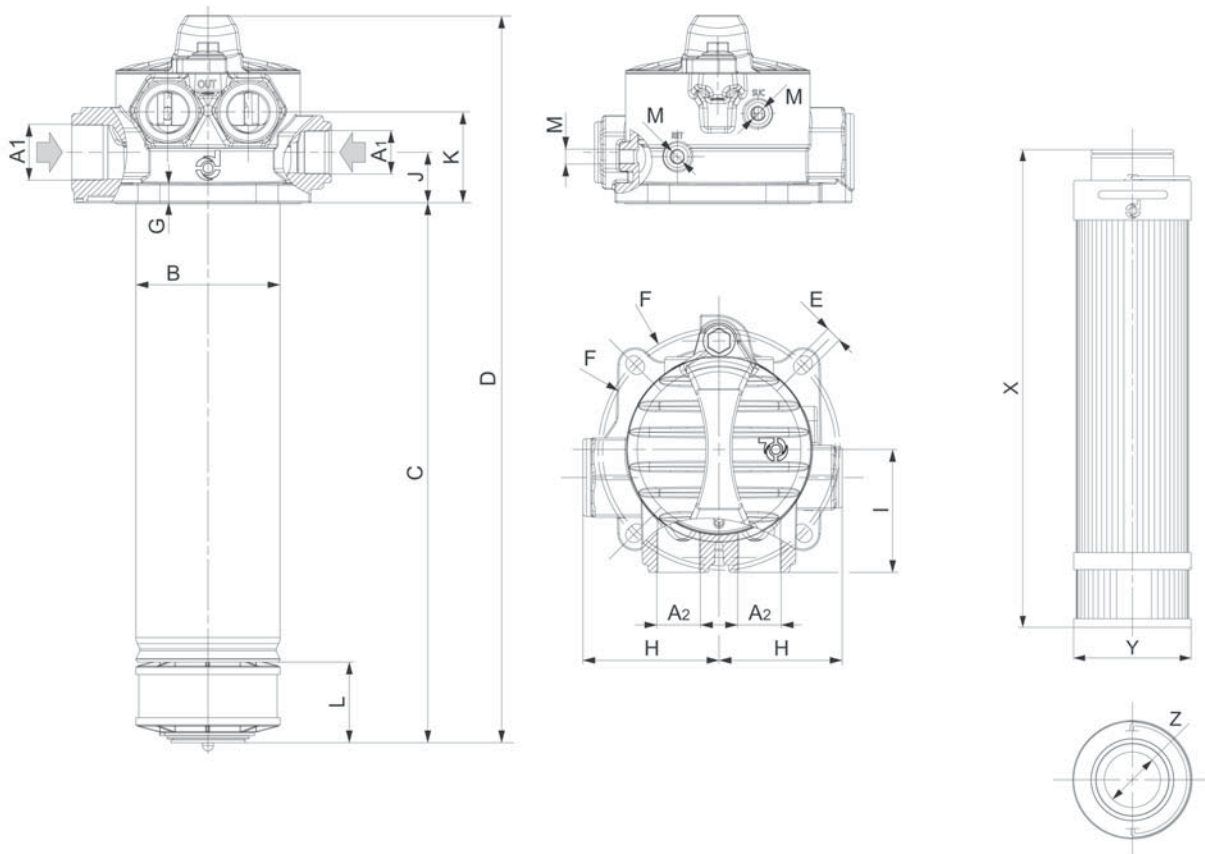

RETURN & SUCTION
FILTERS IN-TANK

Additions

Additional Indicator for SRK 120 (if mounting holes are predrilled) - only on request
P167580

Additional extension tube for SRK 120 - only on request
Extends length of SRK with 178 mm
P763642

Hydraulic Filter Schematics

RETURN & SUCTION
FILTERS IN-TANK

Combo 120

With Emergency Suction

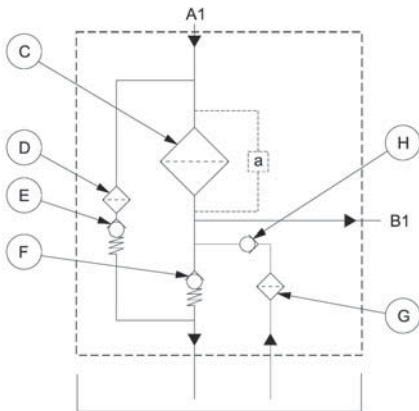

Without Emergency Suction

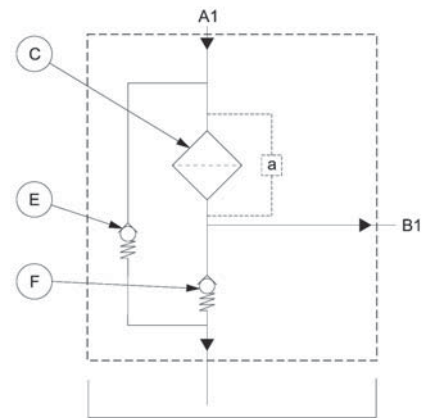

Combo 200/300

With Emergency Suction

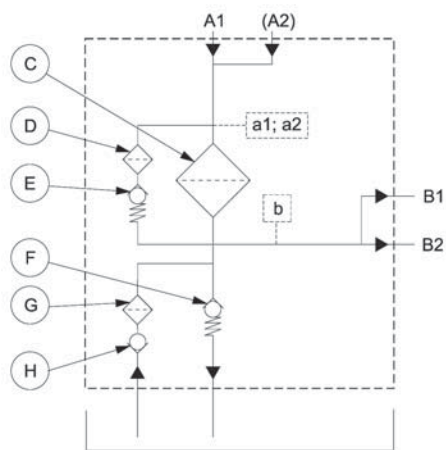

Without Emergency Suction

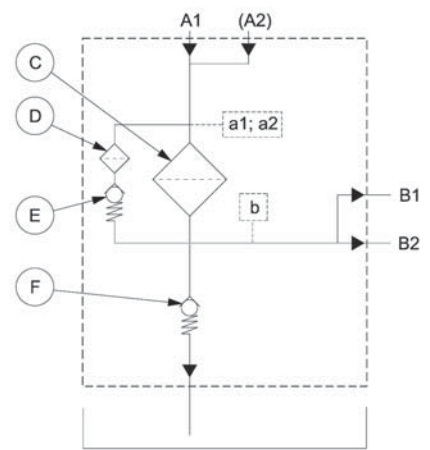

- A1 - A2: from hydraulic users
- B1 - B2: to boost pump
- a, a1, a2, b: pressure indicator ports
- C: main cartridge
- D: by-pass strainer
- E: by-pass valve
- F: back pressure valve
- G: suction strainer
- H: suction valve

Installation & Service Guidelines

- Minimum oil level in the tank must be sufficient to cover completely the emergency suction cartridge or the housing end.
- Extension kit (X770576) is optional for Combo 120 (+178mm).
- Important for the Combo without emergency Suction.

The suction port always gets clean oil. When the element becomes clogged, oil that reaches the suction port is gradually reduced, so the use of an electrical clogging indicator (P165194) is recommended. Return flow must always be higher than suction flow.

- Maximum slope on the installation: 20°.

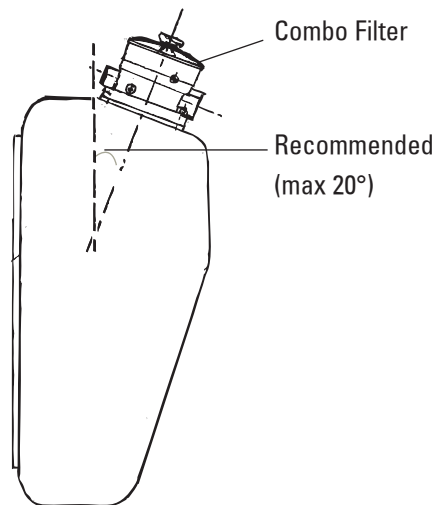

Important

- Oil the O-Rings before assembly.

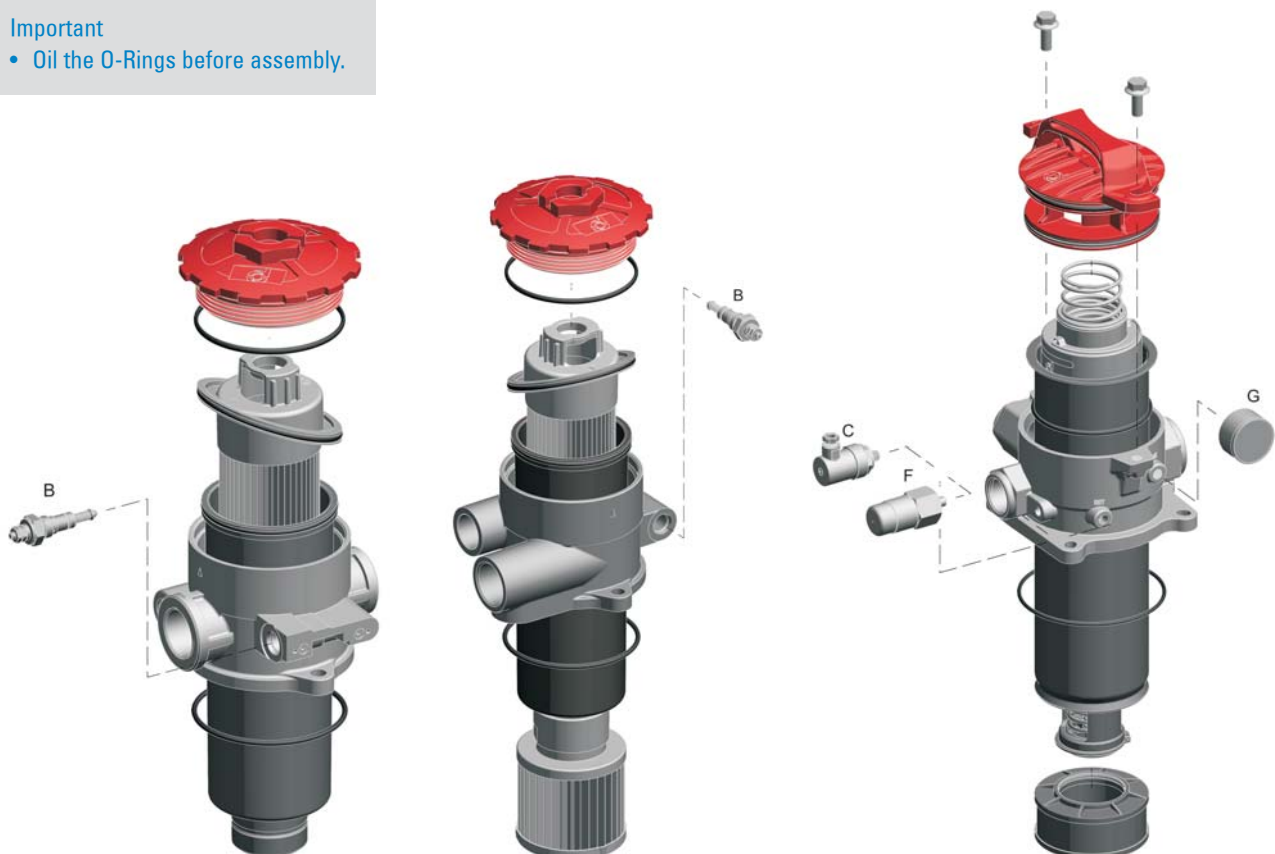

Performance Curves

RETURN & SUCTION
FILTERS IN-TANK

Ports on same Axis

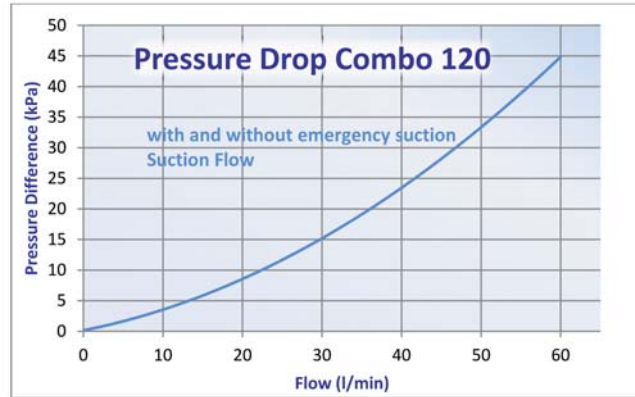
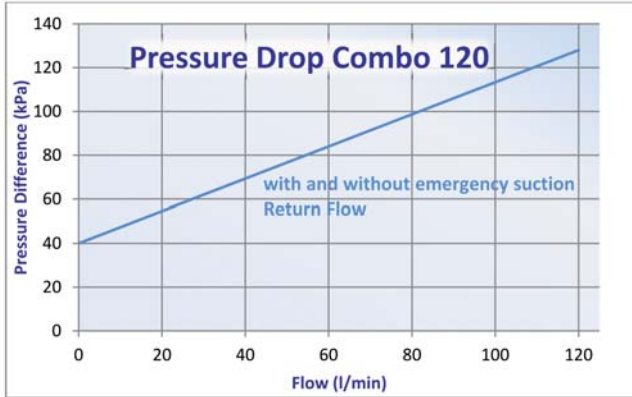

Ports on same Side

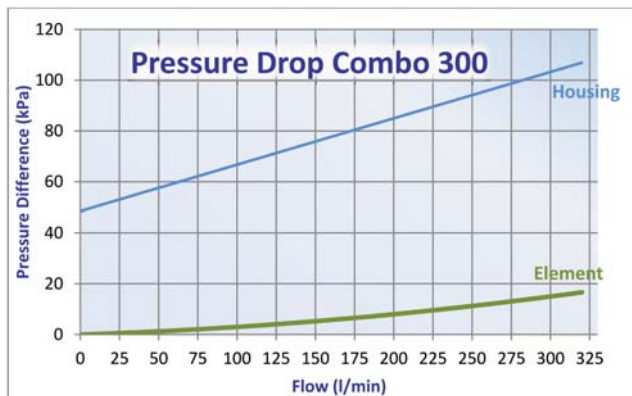
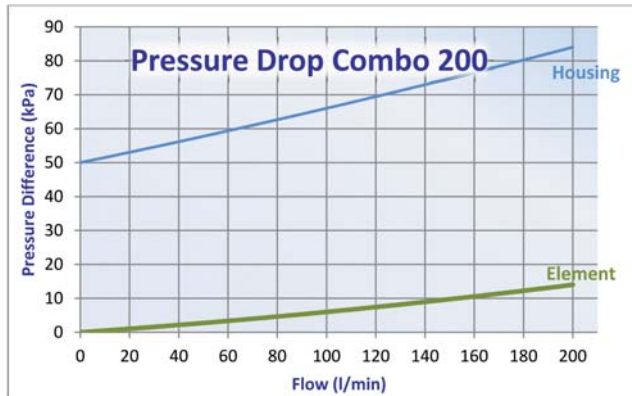
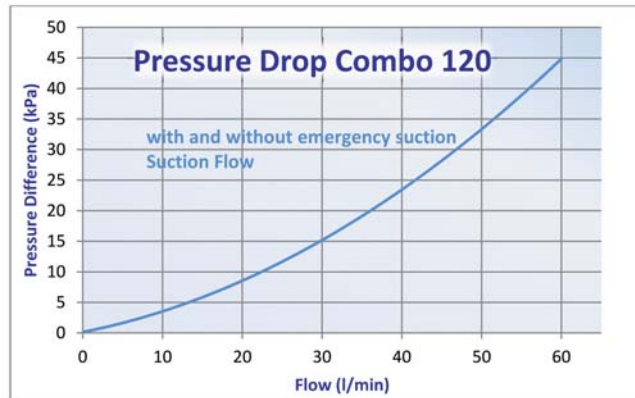
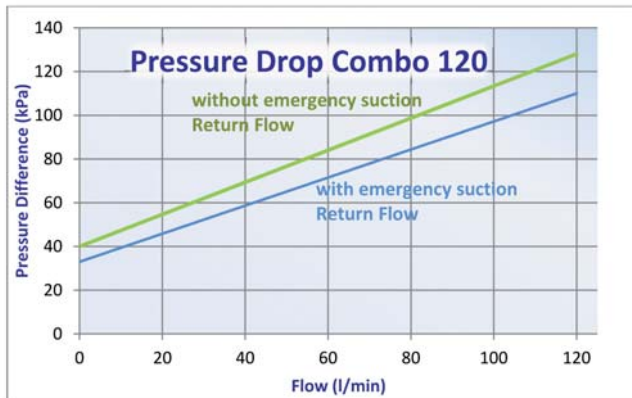



Technical Data

- Operating temperature -20 +120°C.
- Compatibility with hydraulic fluids per ISO 2943.
- Flow rate and pressure drop determined per ISO 3968 with oil kinematic viscosity 30cSt at 40°C and density 0,875 kg/dm³.

Filter Elements

- Wire mesh: 60-90-250 micron.
- Cellulose media: 50 micron.
- Collapse resistance 500 kPa (5 bar) per ISO 2941.

Strainers

SUCTION FILTERS
IN-TANK

Family	WIRE MESH			CELLULOSE MEDIA		CARTRIDGE CODE
	RMF	/9	/6	RMF	/3	
		90µm	60µm		$\beta_{50\mu m(c)}=1000$	
FIOA20	10	P171861	P171863	5	P171862	FIOA20
FIOA35	17	P171865	P171867	9	P171866	FIOA35
FIOA50	25	P171869	P171871	13	P171870	FIOA50
FIOA85	43	P171873	P171875	20	P171874	FIOA85
FIOA90	45	P171877	P171879	25	P171878	FIOA90
FIOA130	65	P171885	P171887	35	P171886	FIOA130
FIOA160	80	P763478	P764370	40	P764371	FIOA160
FIOA175	85	P171889	P171891	45	P171890	FIOA175
FIOA180	90	P172452	P172454	50	P172453	FIOA180
FIOA220	110	P760151	P760173	55	P760175	FIOA220
FIOA230	116	P171893	P171895	60	P171894	FIOA230
FIOA360	186	P171897	P171899	90	P171898	FIOA360
FIOA500	250	P171901	P171903	120	P171902	FIOA500
FIOA600	300	P171905	P171907	150	P171906	FIOA600
FIOA800	400	P171909	P171911	200	P171910	FIOA800

Strainer Dimensions Thread per ISO 228/1				
A	B	C	D	E
	mm	mm	mm	mm
G 3/8	52	68	9	22
G 1/2	69	76	12	27
G 3/4	75	83	12	36
G 1	95	83	14	46
G 1	75	131	10	46
G 1 1/4	95	172	12	60
G 1 1/2	86	130	12	60
G 1 1/2	140	98	15	60
G 1 1/2	95	205	12	60
G 2	101	205	14	80
G 2	140	138	15	80
G 2	140	205	15	80
G 2	140	301	15	80
G 2 1/2	140	301	16	106
G3	140	301	16	106

RMF = Recommended Maximum Flow in liters/minute

WIRE MESH		
Family	RMF	
FIOA90S	45	P765208
FIOA90S	65	P766638

Strainer Dimensions								
Efficiency	A	B	C	D	E	F	BPV	Reference Drawing
μm		mm	mm	mm	mm	mm	bar	
90	diam 32	M48x1.5	155	48	45	50	NA	B
125	M45x2	M48x2	150	26	44	55	1	A

BPV= Bypass Valve Setting

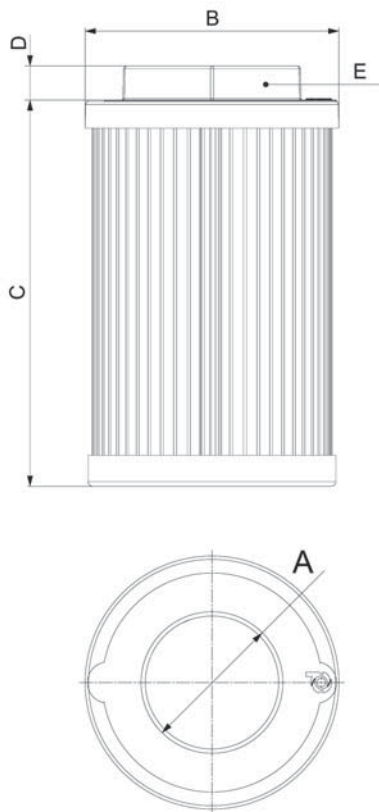

Reference Drawing A

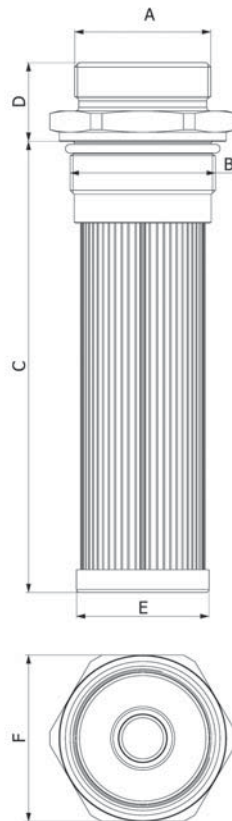

Reference Drawing B

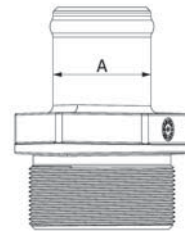

Important

- The strainer thread must be lubricated before spinning on the strainer to prevent thread damage. Heavyweight gear lube is recommended.
- Oil the O-Rings before assembly.

Performance Curves

SUCTION FILTERS
IN-TANK

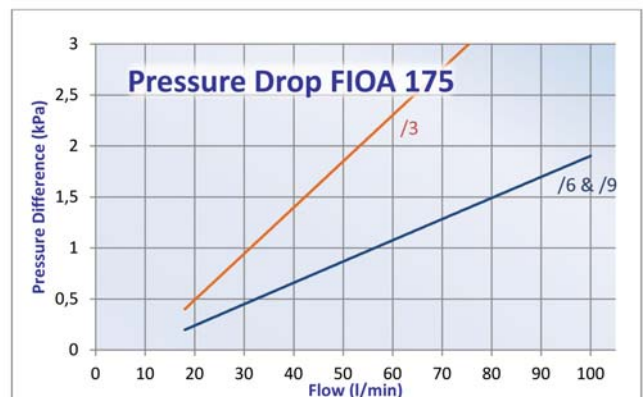
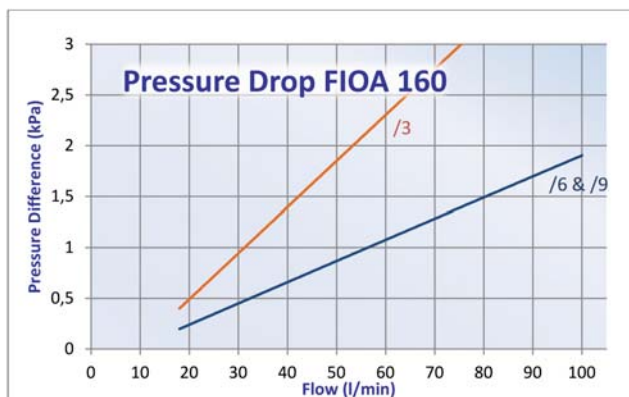
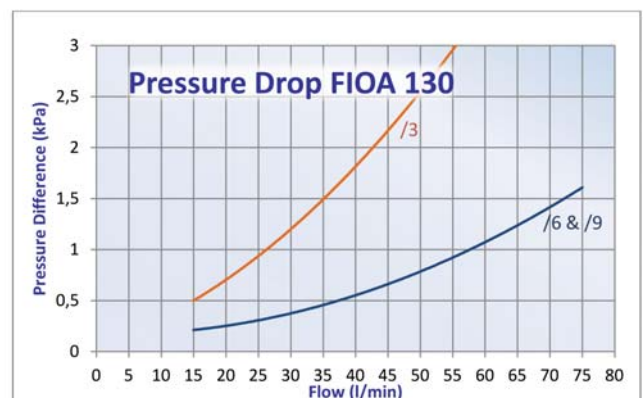
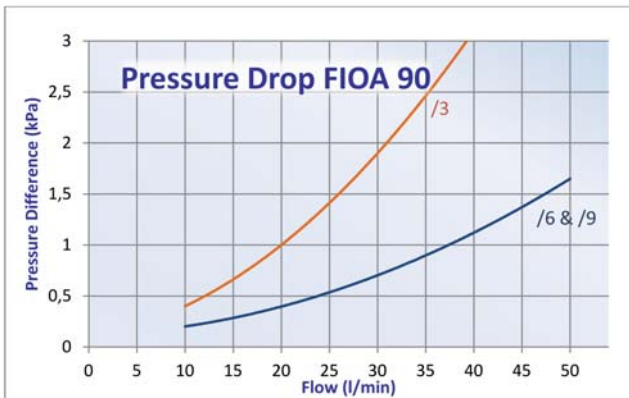
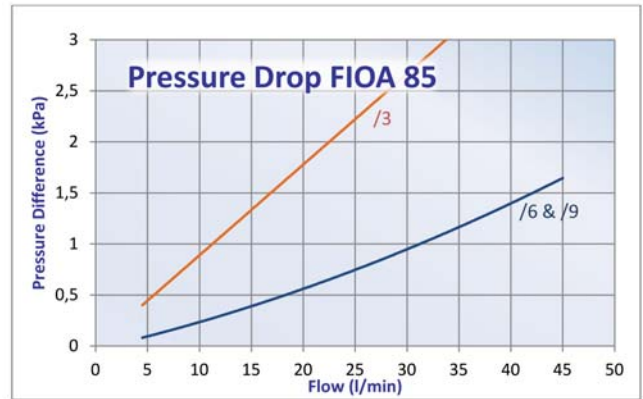
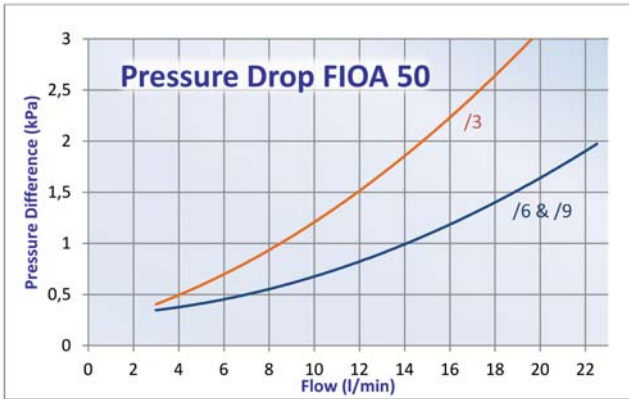
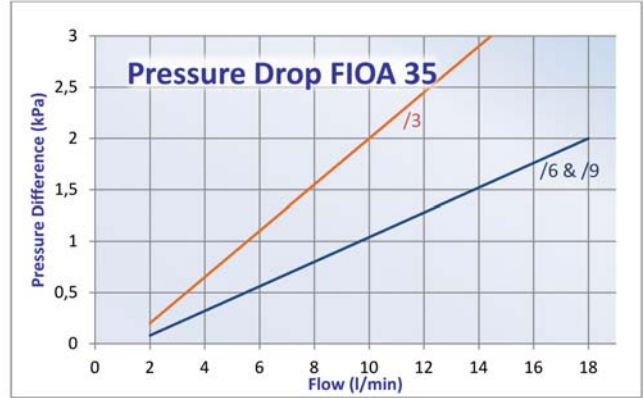
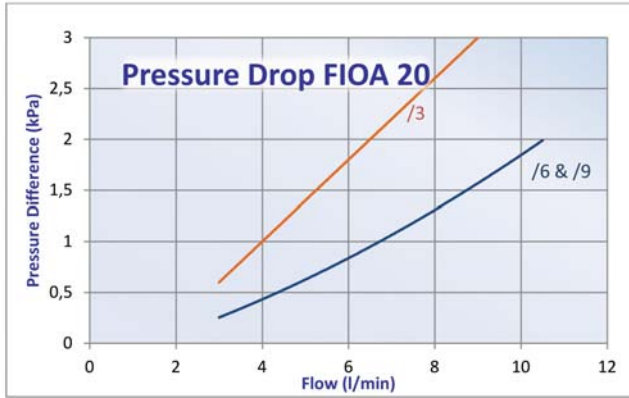

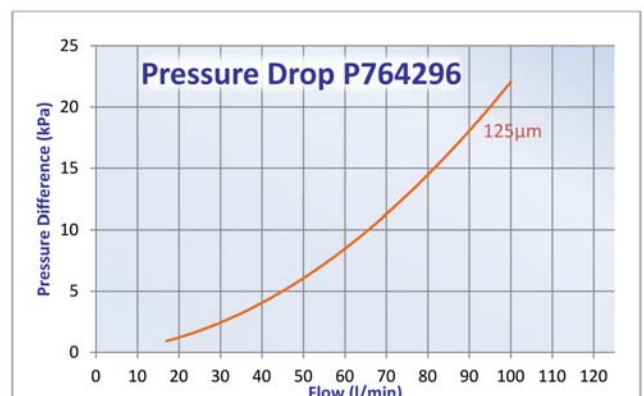
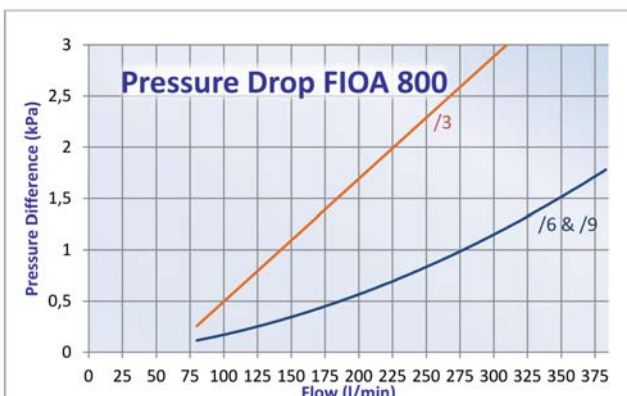
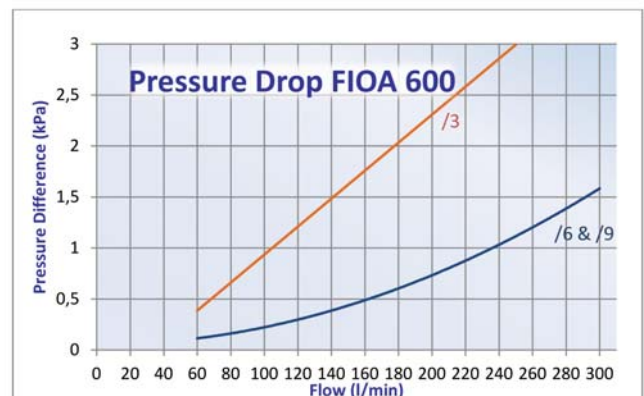
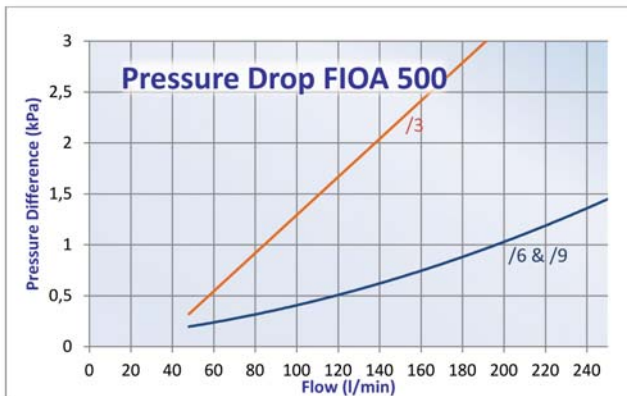
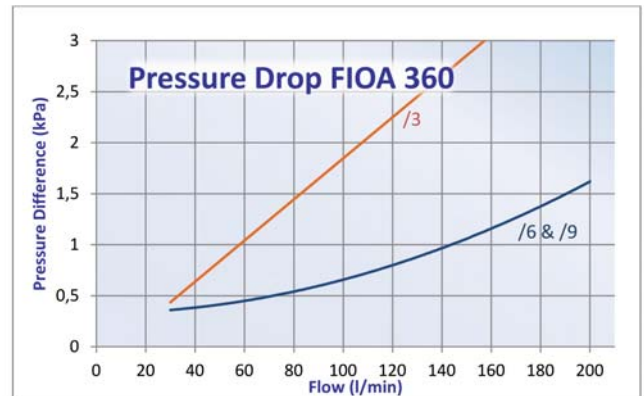
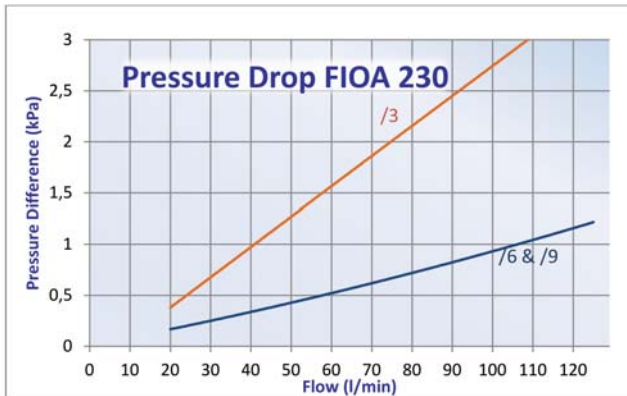
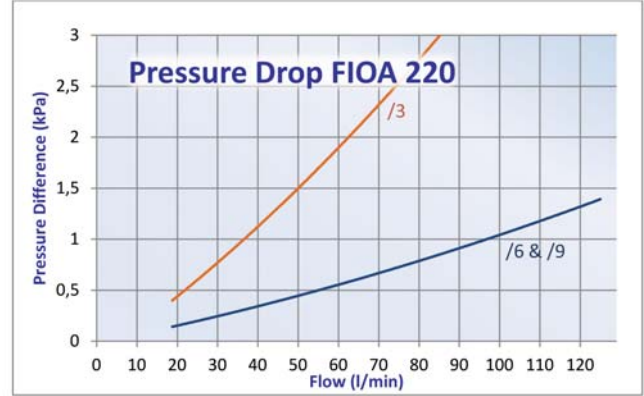
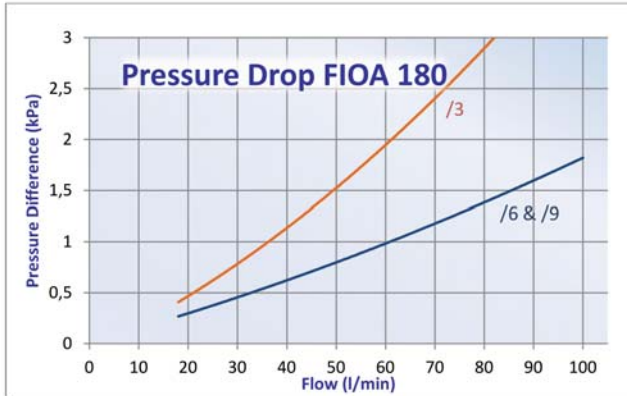

SUCTION FILTERS
IN-TANK

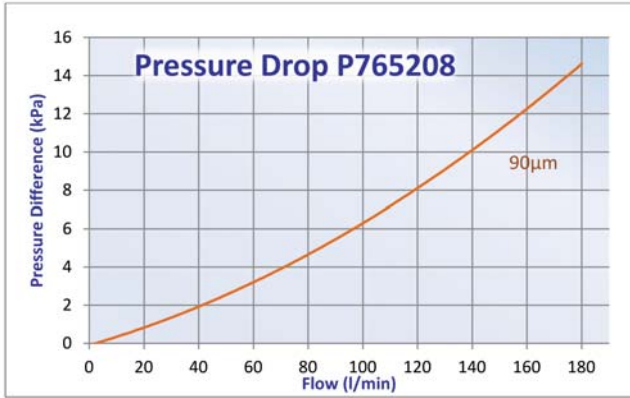

SUCTION FILTERS
IN-TANK



Technical Data

- Operating pressure up to 400 kPa (4 bar).
- Static pressure testing up to 600 kPa (6 bar).
- Operating temperature -20 +120° C.
- Compatibility with hydraulic fluids per ISO 2943.
- Flow rate and pressure drop determined per ISO 3968 with oil kinematic viscosity 30 cSt at 40°C and density 0,875 kg/dm³.

Filter Elements

- Wire mesh: 160 micron.
- Collapse resistance 500 kPa (5 bar) per ISO 2941.



Components

		WIRE MESH MEDIA	
		/160	
		160µm	
Family	RMF		
FAL25	25	P176903	
FAL45	45	P175142	
FAL65	65	P175143	
FAL85	85	P761040	
FAL100	100	P176904	

FILTER DIMENSIONS					
A	B	C	D	E	F
mm	mm	mm	mm	mm	mm
19	26	19	20	74	149
30	23	30	18	74	145
38	23	38	18	74	145
38	23	38	20	74	208
50	22	50	22	85	181

RMF = Recommended Maximum Flow in liters/minute

SUCTION FILTERS
IN-LINE

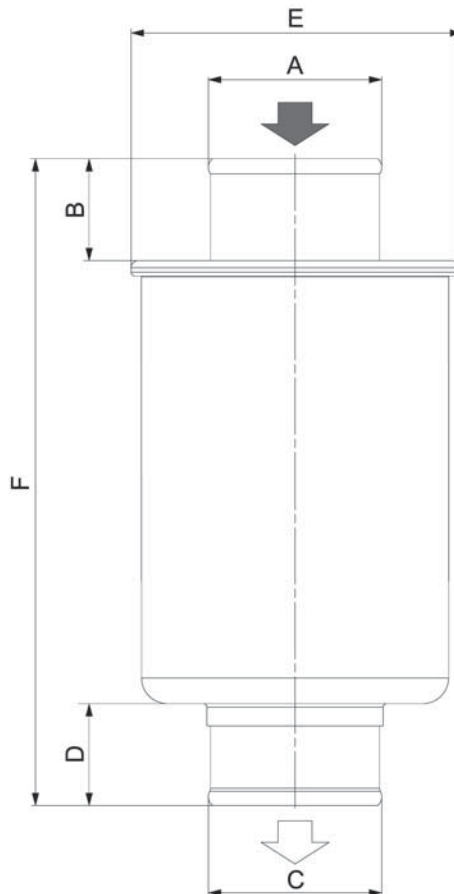

Performance Curves

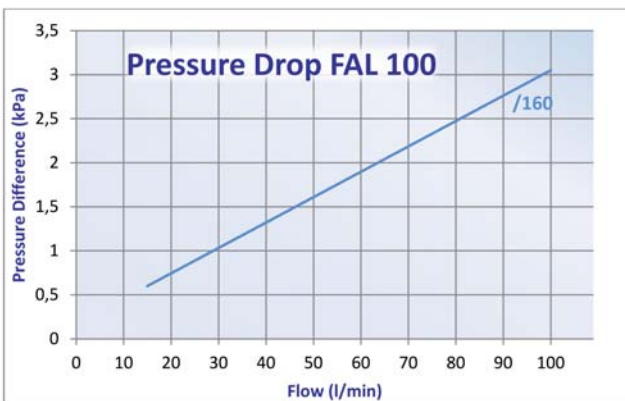
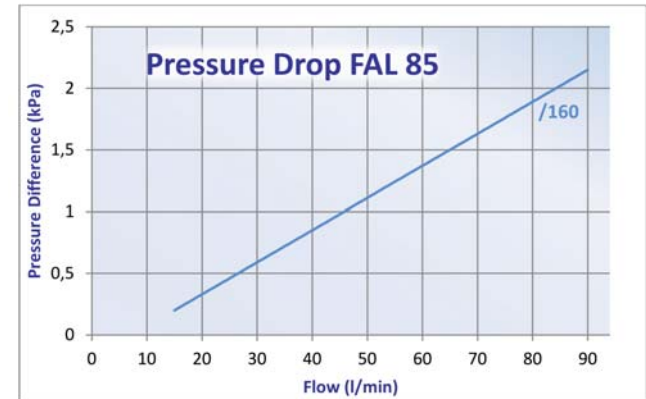
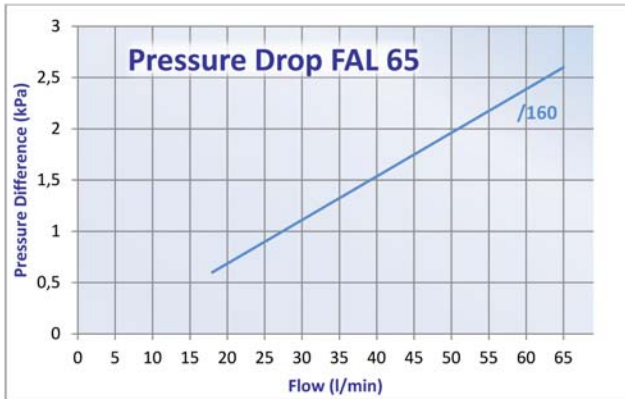
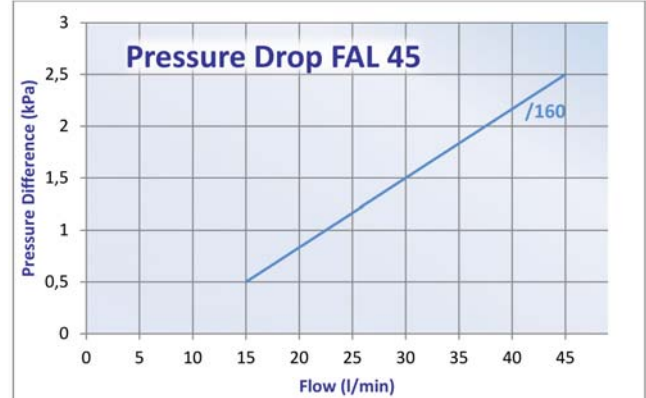
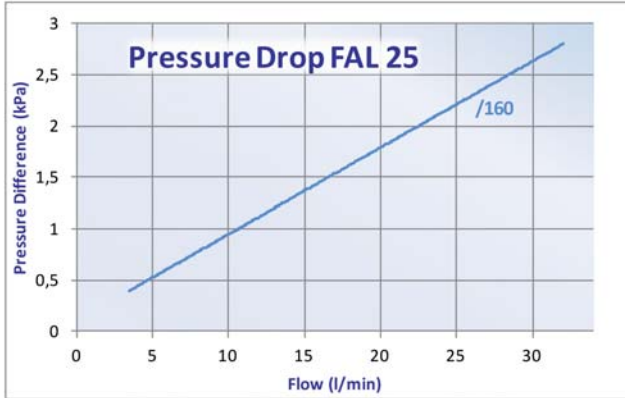

SUCTION FILTERS
IN-LINE

FLK-FLS FLK-FLA

Open empty housing
in correct order



Remove carton ring
before use



Check if O-ring between
lid and housing is installed
and intact



Check if O-Ring on cartridge
is installed and intact

For FLK:
Mount O-ring over stud

For Low Pressure cartridges:
Mount spring on cartridge

Mount element in
housing



For Combo 120:
Align arrows as shown



Assemble lid on housing



Assemble bolts and
screws in correct order



Tighten screws, bolts or lid until
thread ends
For spin-ons: hand tighten until
contact between O-ring and
head is made; and then continue
by hand as indicated on spin-on



Degrease surface where
sparepart sticker will be
mounted
Only for cartridge type filters



Sparepart sticker in each
sparepart box



Fix sparepart sticker in area
indicated – Ready!



Do not forget seals





Mix&Match to Get What You Need

Donaldson's Mix&Match system provides the great performance and functional advantages of custom-engineered filters with the convenience and speedy delivery of in-stock parts. Choose your options and build a filter model that exactly suits your cleanliness requirements.

Technical Data

- Operating pressure up to 3000 kPa (30 bar).
- Static pressure testing up to 4500 kPa (45 bar).
- By-pass valve setting 30 kPa (0,3 bar) per ISO 3968.
- Operating temperature -20 +120°C.
- Compatibility with hydraulic fluids per ISO 2943.
- Flow rate and pressure drop per ISO 3968 with oil kinematic viscosity 30 cSt at 40°C and density 0,875 kg/dm³.
- Flange per SAE J518: 3000 PSI.

Filter Elements

- Wire mesh: 60-90 micron.
- Cellulose media: 36-50 micron.
- Synteq® synthetic media: 11-23 micron.
- Collapse resistance 1000 kPa (10 bar) per ISO 2941.
- Replacement element includes spring and O-ring seal.



Components

Family	WIRE MESH				CELLULOSE MEDIA				SYNTHETIC MEDIA				CARTRIDGE CODE
	/9		/6		/3		/1		/03		XP10		
	90µm		60µm		$\beta_{50\mu m(e)} \geq 1000$		$\beta_{36\mu m(e)} \geq 1000$		$\beta_{23\mu m(e)} \geq 1000$		$\beta_{11\mu m(e)} \geq 1000$		
	RMF		RMF	RMF		RMF		RMF		RMF			
FLA50	20	P171518	20	P171523	15	P171522	15	P171521	10	P171520	10	P171519	CR50
FLA100	40	P171530	40	P171535	30	P171534	30	P171533	25	P171532	25	P171531	CR100
FLA150	65	P171584	65	P171589	55	P171588	55	P171587	45	P171586	45	P171585	CR125
FLA180	90	P171536	90	P171541	60	P171540	60	P171539	55	P171538	55	P171537	CR180
FLA200	100	P171596	100	P171601	70	P171600	70	P171599	80	P171598	80	P171597	CL200
FLA250	125	P171590	125	P171595	80	P171594	80	P171593	70	P171592	70	P171591	CR220
FLAF 250	125	P171590	125	P171595	80	P171594	80	P171593	70	P171592	70	P171591	CR220
FLA330	170	P171560	170	P171565	110	P171564	110	P171563	90	P171562	90	P171561	CR330
FLAF 330	170	P171560	170	P171565	110	P171564	110	P171563	90	P171562	90	P171561	CR330
FLA500	250	P171566	250	P171571	200	P171570	200	P171569	170	P171568	170	P171567	CR500
FLAF 500	250	P171566	250	P171571	200	P171570	200	P171569	170	P171568	170	P171567	CR500
FLAF 800	300	P171578	300	P171583	250	P171582	250	P171581	200	P171580	200	P171579	CR800

RMF = Recommended Maximum Flow in liters/minute with use of standard housing.

All housings are predrilled and holes are plugged, you are not obliged to install an indicator.

The Bypass valve is installed in the head of the filter. The Cartridges have also a Bypass valve, but at a higher setpoint.

FLA 50-180

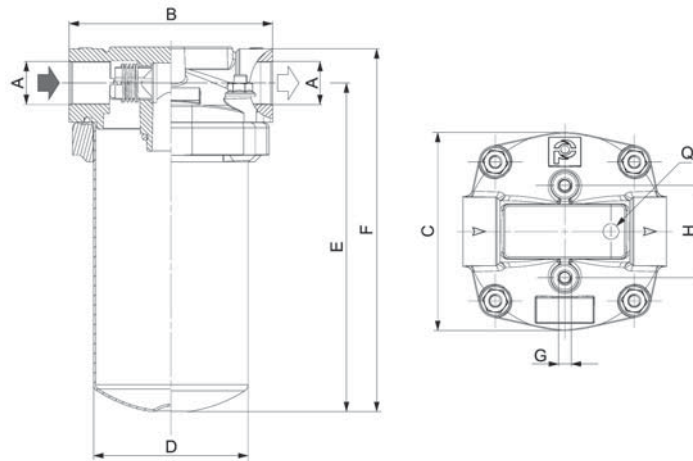

FLA 200

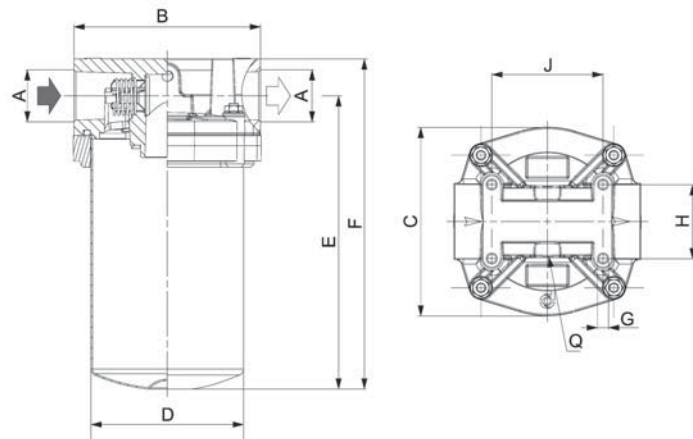

Standard Housing without Cartridge	HOUSING DIMENSIONS																CARTRIDGE DIMENSIONS			POSSIBLE INDICATOR
	A	B	C	D	E	F	G	H	J	K	L	M	N	P	Q	R	X	Y	Z	
		mm	mm	mm	mm	mm	mm	mm	mm	mm	mm	mm	mm	bar	predrilled holes	plugged	mm	mm	mm	
P766484	G1/2	119	116	90	140	161	M8	54	-	-	-	-	-	0,3	G 1/8	YES	75	70	29	P171954 P171959 P171967 P173105
P766485	G3/4	119	116	90	192	213	M8	54	-	-	-	-	-	0,3	G 1/8	YES	128	70	29	
P766486	G1	140	135	109	246	277	M8	68	-	-	-	-	-	0,3	G 1/8	YES	169	95	41	
P766487	G1 1/4	140	135	109	284	314	M8	68	-	-	-	-	-	0,3	G 1/8	YES	209	95	41	
P766488	G1 1/4	151	153	123	238	268	M8	60	90	-	-	-	-	0,3	G 1/8	YES	180	112	46	
P766489	G1 1/2	212	208	169	225	269	M8	96	96	-	-	-	-	0,3	G 1/8	YES	136	140	65	
P766490	Flange 1" 1/2	212	208	169	225	269	M8	96	96	70	36,7	M12	22	0,3	G 1/8	YES	136	140	65	
P766491	G1 1/2	212	208	169	295	339	M8	96	96	-	-	-	-	0,3	G 1/8	YES	203	140	65	
P766492	Flange 1" 1/2	212	208	169	295	339	M8	96	96	70	36,7	M12	22	0,3	G 1/8	YES	203	140	65	
P766493	G2	212	208	169	296	339	M8	96	96	-	-	-	-	0,3	G 1/8	YES	203	140	65	
P766494	Flange 2"	212	208	169	295	339	M8	96	96	77,8	42,8	M12	22	0,3	G 1/8	YES	203	140	65	
P766495	Flange 2"	212	208	171	495	539	M8	96	96	77,8	42,8	M12	22	0,3	G 1/8	YES	400	140	65	

FLA 250-800

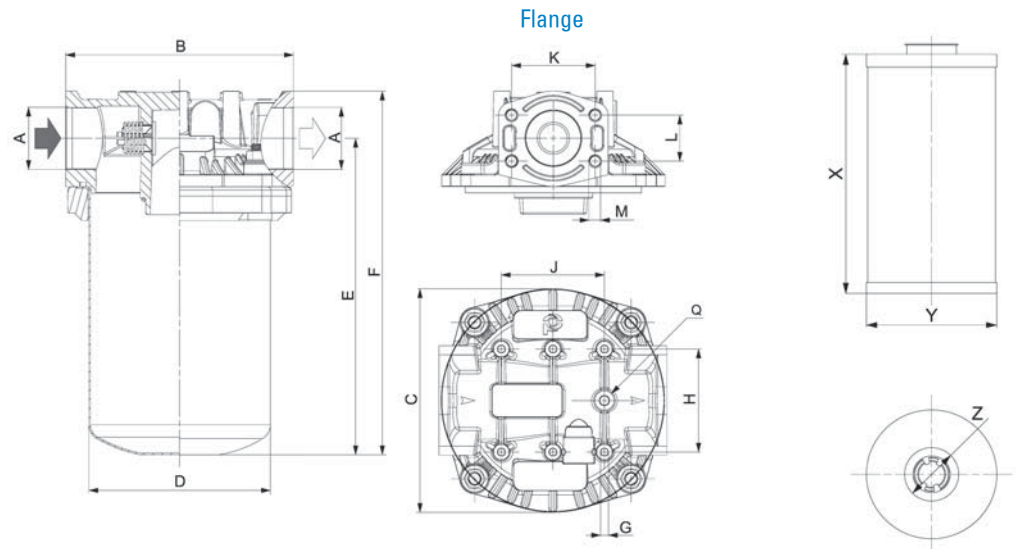

SUCTION FILTERS
IN-LINE

Indicator Choices

Part	Kind		Reference Drawing	Setting (bar)	Contact	Protection Class	Cable Clamp	Max. Values
P171954	Visual	Vacuum	G	-0,3				
P171959	Visual	Vacuum	N	-0,3				
P171967	Electrical	Vacuum	C	-0,3	Normally Open	IP65	PG7	48 VAC - 30 VDC; 0,5 A res. and 0,2 A ind.
P173105	Electrical	Vacuum	C	-0,3	Normally Closed	IP65	PG7	48 VAC - 30 VDC; 0,5 A res. and 0,2 A ind.

SUCTION FILTERS
IN-LINE

Installation & Service Guidelines

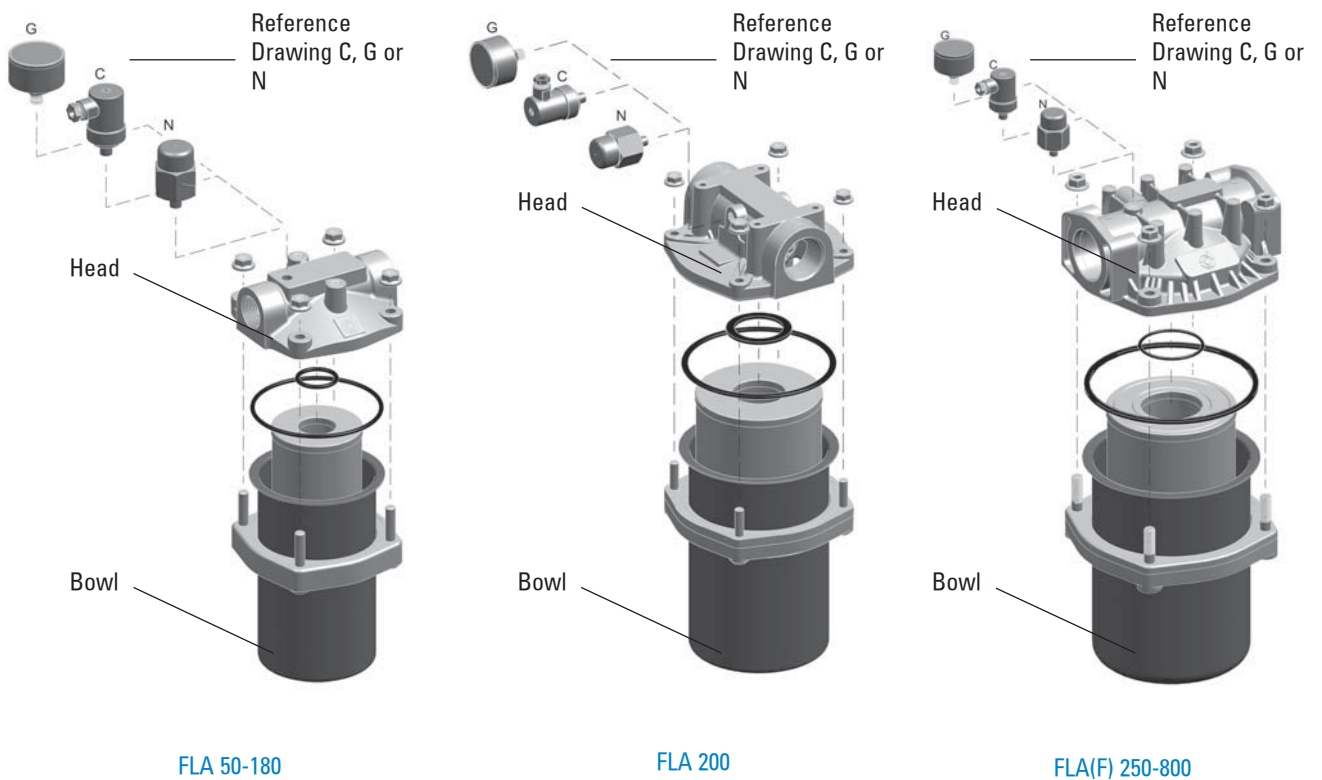

Performance Curves

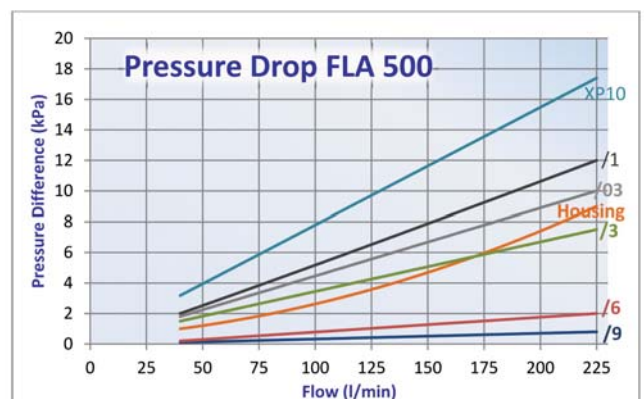
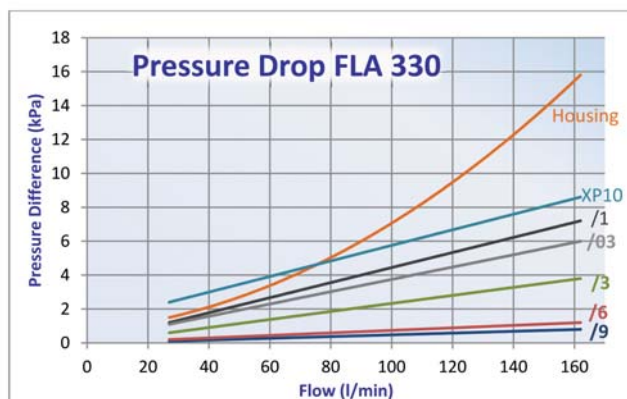
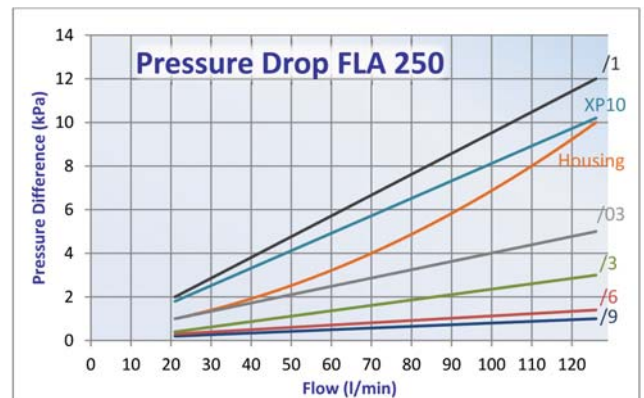
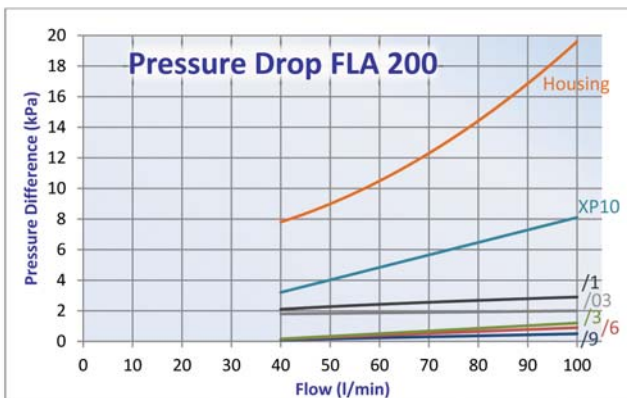
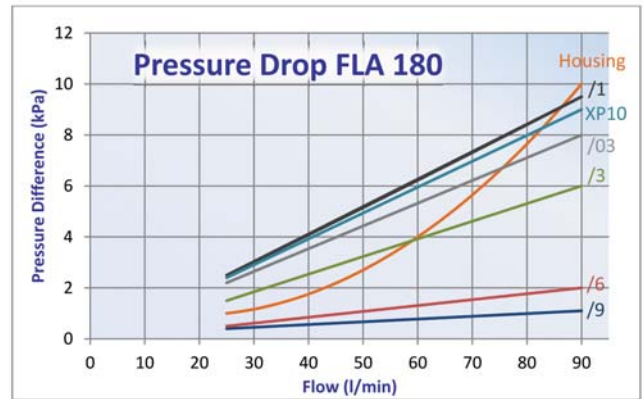
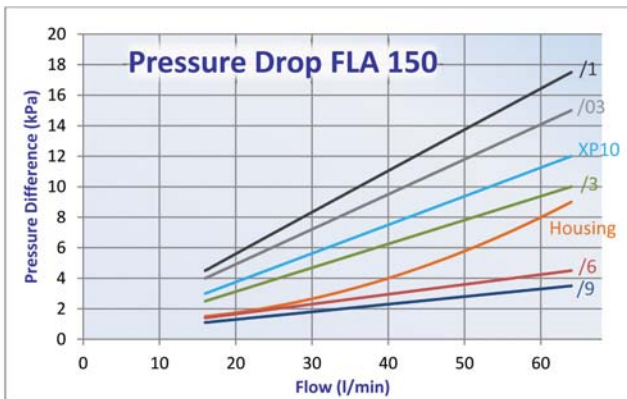
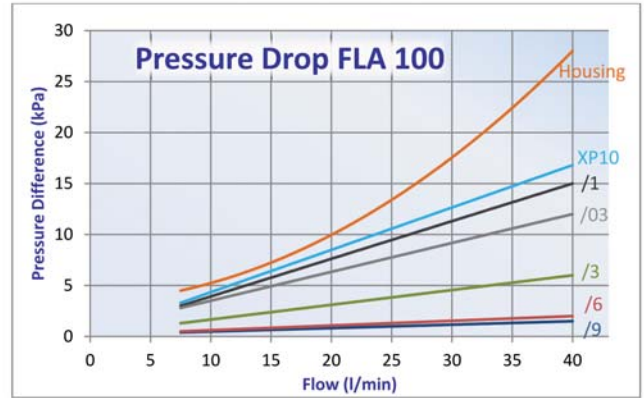
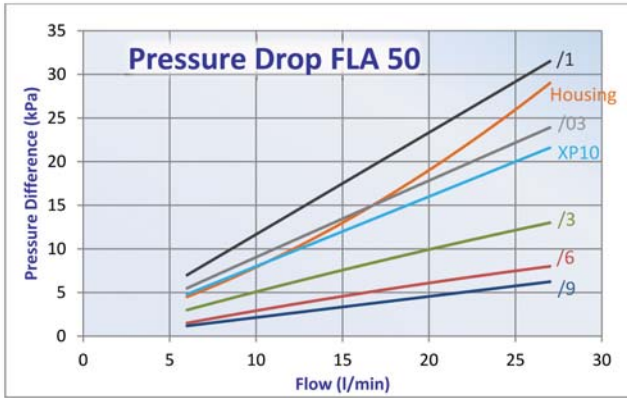

SUCTION FILTERS
IN-LINE

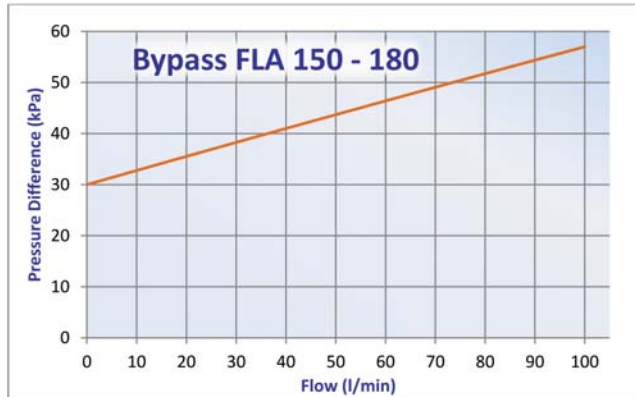
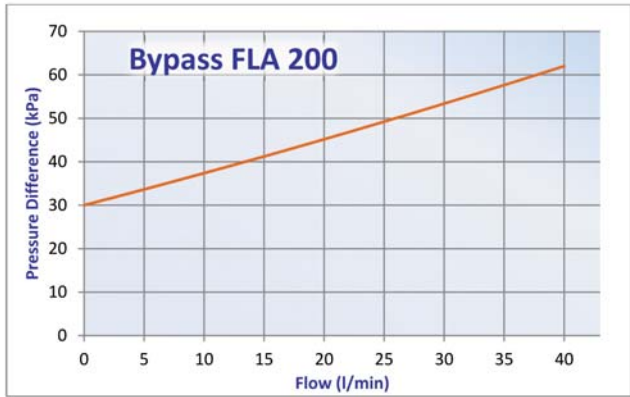
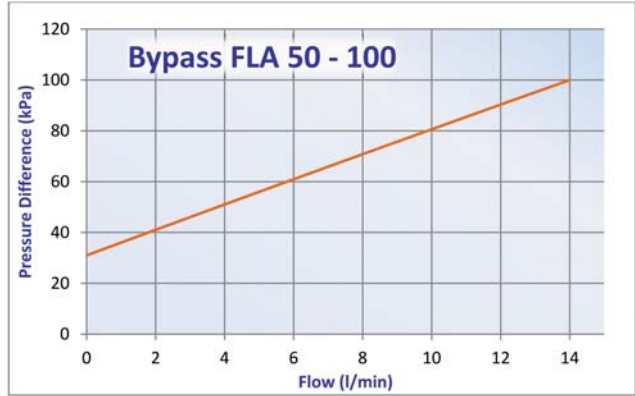
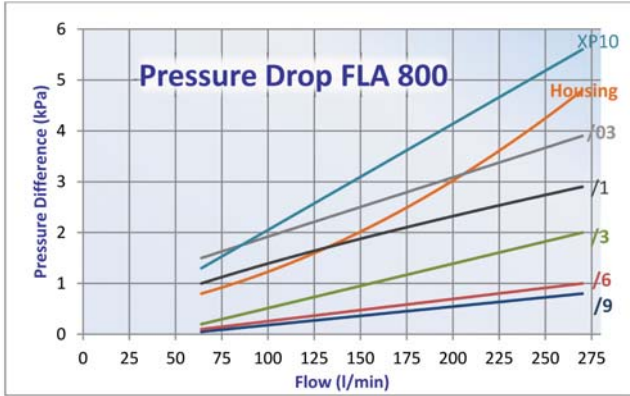

SUCTION FILTERS
IN-LINE



Mix&Match to Get What You Need

Donaldson's Mix&Match system provides the great performance and functional advantages of custom-engineered filters with the convenience and speedy delivery of in-stock parts. Choose your options and build a filter model that exactly suits your cleanliness requirements.

Technical Data

- Operating pressure up to 1000 kPa (10 bar).
- Static pressure testing up to 1500 kPa (15 bar).
- By-pass valve setting 30 kPa (0,3bar) per ISO 3968.
- Operating temperature -20 +120°C.
- Compatibility with hydraulic fluids per ISO 2943.
- Flow rate and pressure drop determined per ISO 3968 with oil kinematic viscosity 30 cSt at 40°C and density 0,875 kg/dm³.

Filter Elements

- Operating pressure up to 1000 kPa (10 bar).
- Static pressure testing up to 1500 kPa (15 bar).
- Collapse resistance 1000 kPa (10 bar) per ISO 2941.
- Wire mesh: 60 micron.
- Cellulose media: 36-50 micron.
- Synteq® synthetic media: 11-23 micron.



Components

	WIRE MESH MEDIA		CELLULOSE MEDIA				SYNTHETIC MEDIA				CARTRIDGE CODE
	/6		/3		/1		/03		XP10		
	60µm		$\beta_{50\mu m(c)} \geq 1000$		$\beta_{36\mu m(c)} \geq 1000$		$\beta_{23\mu m(c)} \geq 1000$		$\beta_{11\mu m(c)} \geq 1000$		
Family	RMF		RMF		RMF		RMF		RMF		
FACA60	30	P171607	25	P171606	20	P550268	15	P171604	15	P171602	CA60
FACA80	35	P171612	30	P171611	25	P171610	20	P171609	20	P171608	CA80
FACA108			50	P764638							CA108
FACA118			60	P763987							CA108
FACA160	80	P171617	80	P171616	70	P550148	60	P171614	60	P171613	CA160
FACA200	100	P171622	100	P171621	90	P171620	80	P171619	80	P171618	CA200
FACA380	190	P171617	190	P171616	170	P550148	150	P171614	150	P171613	CA160
FACA400	200	P171622	200	P171621	180	P171620	180	P171619	180	P171618	CA200
FACA220			100	P764410					80	P764411	CA220
FACA250			120	P764409					90	P763668	CA250

RMF = Recommended Maximum Flow in liters/minute with use of standard head.
 BPV = Bypass Valve Setting

Heads Choices



Head for Family	Part	Ports	Bypass Valve Setting	Indicator Info			Snout	Mounting holes
				Drilled holes for indicator	Side	Indicator to use		
FACA 60/80	P561140	1 1/16 SAE	0,3 bar	no	-	none	1-12 UNF	M8
	P563288	1/2-14 NPTF	1 bar	plugged	left + right	P563979 or P563299	1-12 UNF	1/4-20 UNC
	P561138	3/4-16 UNF	1,7 bar	no	-	none	1-12 UNF	1/4-20 UNC
	P761262	G3/4	0,3 bar	plugged	left + right	P171954, P171959, P171967 or P173105	G3/4	M8
	P173442*	G3/4	0,3 bar	no	-	none	G3/4	M8
	P175001	G3/4	no opening	plugged	left + right	P171954, P171959, P171967 or P173105	G3/4	M8
FACA 160/200	P761259	G1 1/4	0,3 bar	plugged	left + right	P171954, P171959, P171967 or P173105	G1 1/4	M8
	P173203*	G1 1/4	0,3 bar	no	-	none	G1 1/4	M8
	P762638	G1 1/4	1,5 bar	plugged	right	P171954, P171959, P171967 or P173105	G1 1/4	M8
	P173403	G1 1/4	no opening	plugged	left + right	P171954, P171959, P171967 or P173105	G1 1/4	M8
FACA 220/250	P764420	G1 1/4	0,3 bar	plugged	right	P171954, P171959, P171967 or P173105	1 1/2-16 UN	M10
	P764419*	G1 1/4	0,3 bar	no	-	none	1 1/2-16 UN	M8
	P764421	G1 1/4	no opening	plugged	right	P171954, P171959, P171967 or P173105	1 1/2-16 UN	M8
FACA 380/400	P761260	G1 1/2	0,3 bar	plugged	front	P171954, P171959, P171967 or P173105	G1 1/4	M10
	P766294*	G1 1/2	0,3 bar	no	-	none	G1 1/4	M10

FBK Filters aren't delivered with drilled holes for indicators or bypass valve, heads are.
 Unless otherwise mentioned, the usage of indicators is mandatory, because the drilled holes for indicators are not plugged.

* Standard Head

SUCTION FILTERS IN-LINE



Standard Head	HEAD DIMENSIONS									SPIN-ON DIMENSIONS		
	A	B	C	D	E	F	G	S	BPV	X	Y	Z
		mm	mm	mm		mm	mm	mm	bar	mm	mm	
P173442	G3/4	95	13	41,5	M8	38		20	0,3	146	96	G3/4
										209	96	G3/4
NA										183	108	M40x2
										230	108	M40x2
P173203	G1 1/4	132	28,5	61,5	M8	50		24	0,3	181	128	G1 1/4
										226	128	G1 1/4
P766294	G1 1/2	138	35	70	M10		65	24	0,3	181	128	G1 1/4
										226	128	G1 1/4
P764419	G1 1/4	132	28,5	61,5	M8	50	50	25	0,3	236	136	1 1/2-16UN
										306	136	1 1/2-16UN

FACA 60/80

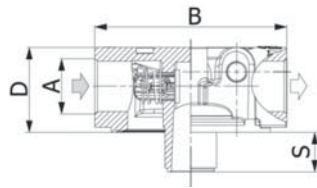

LEFT

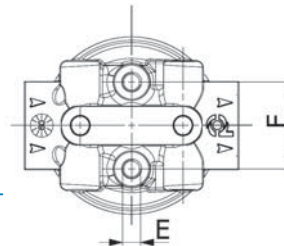

RIGHT

FACA 160/200

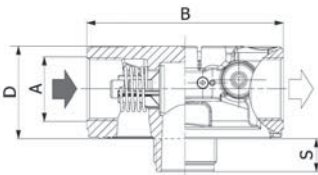

LEFT

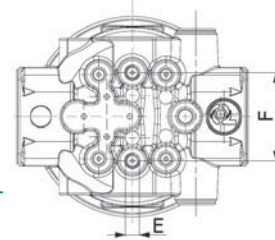

RIGHT

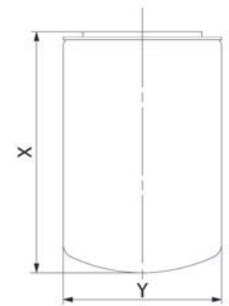

FACA 220/250

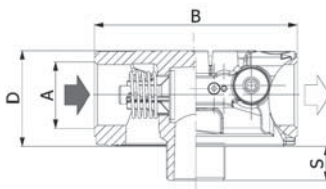

LEFT

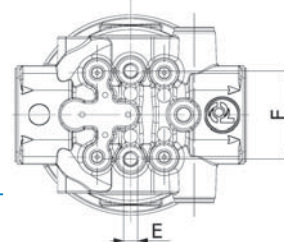

RIGHT

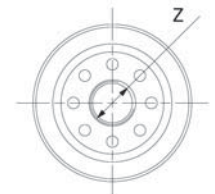

FACA 380/400

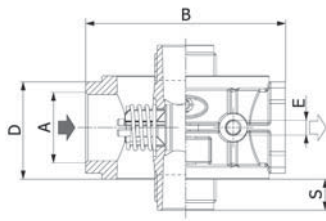

FRONT

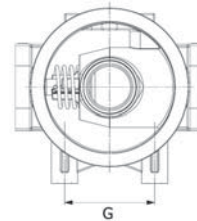

Indicator Choices

Indicator	Kind		Reference Drawing	Setting (bar)	Contact	Protection Class	Cable Clamp	Max. Values
P171967	Electrical	Vacuum	C	-0,3	Normally Open	IP65	PG7	48 V AC - 30 V DC; 0,5 A res. and 0,2 A ind.
P173105	Electrical	Vacuum	C	-0,3	Normally Closed	IP65	PG7	48 V AC - 30 V DC; 0,5 A res. and 0,2 A ind.
P171954	Visual	Vacuum	G	-0,3				
P171959	Visual	Vacuum	N	-0,3				

SUCTION FILTERS
IN-LINE

Installation & Service Guidelines

Important

- The filter head snout must be lubricated before spinning on a new filter to prevent thread damage. Heavyweight gear lube is recommended.
- Oil the O-Rings before assembly.

Performance Curves

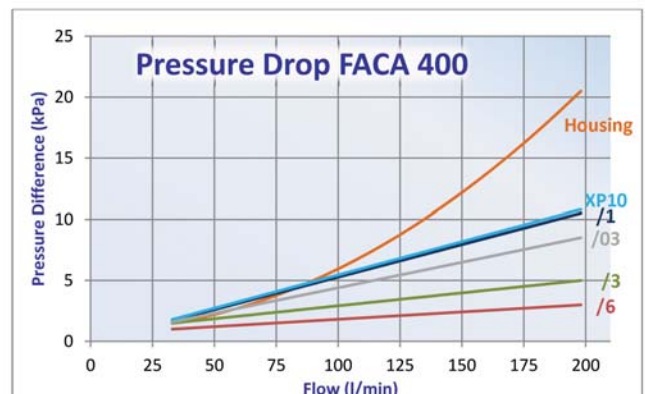
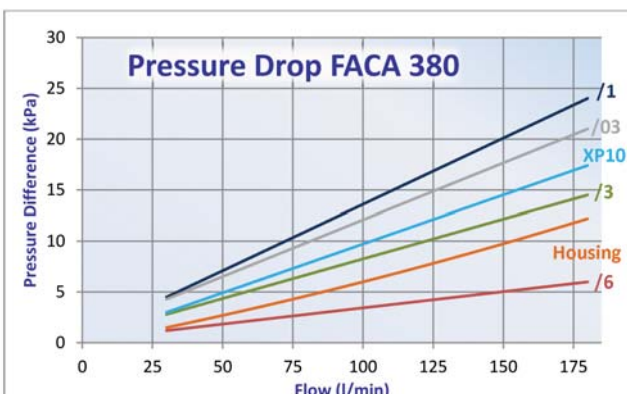
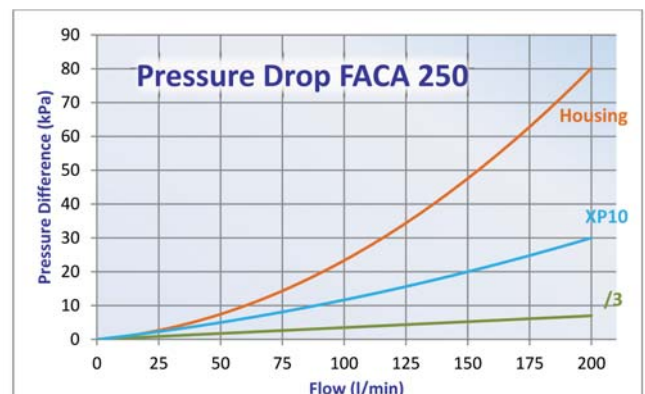
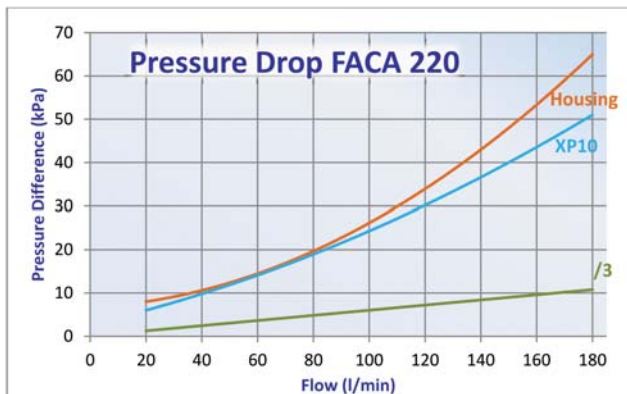
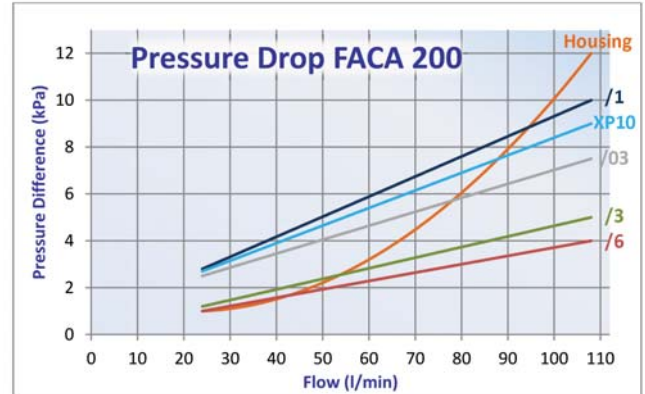
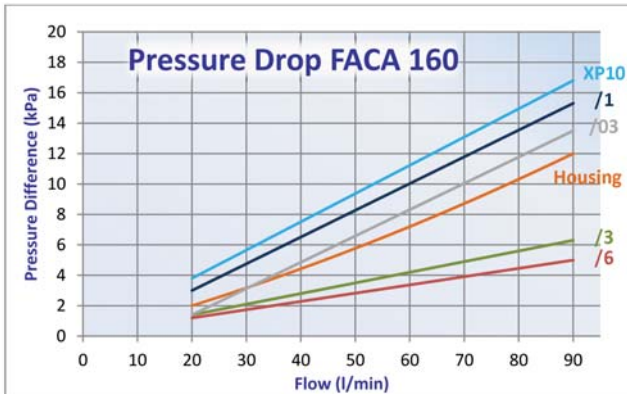
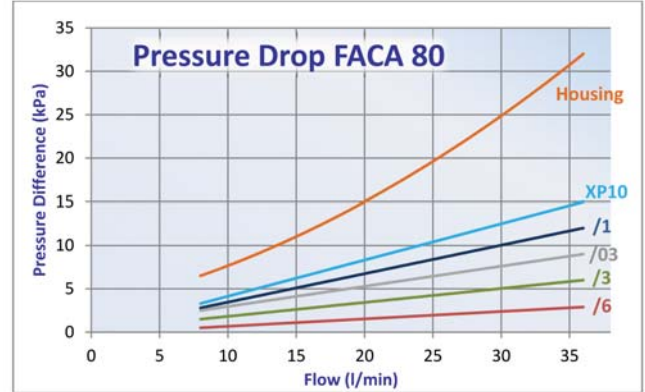
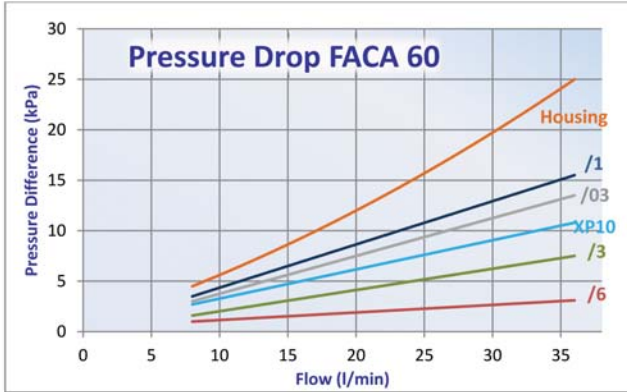

SUCTION FILTERS
IN-LINE

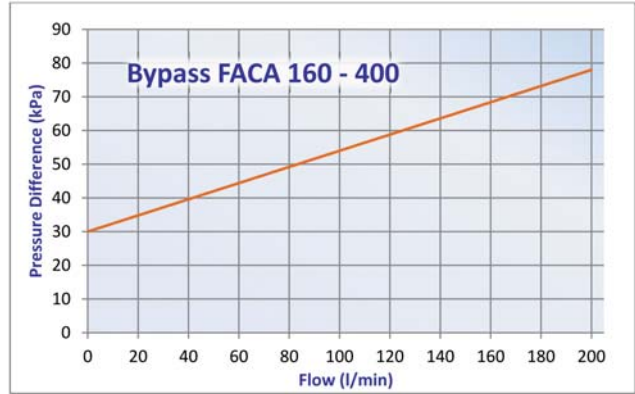
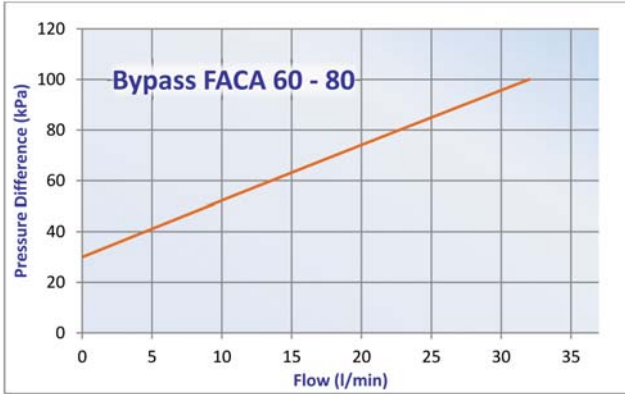

SUCTION FILTERS
IN-LINE



Mix&Match to Get What You Need

Donaldson's Mix&Match system provides the great performance and functional advantages of custom-engineered filters with the convenience and speedy delivery of in-stock parts. Choose your options and build a filter model that exactly suits your cleanliness requirements.

Technical Data

- Operating pressure up to 12 MPa (120 bar).
- Static pressure testing up to 18 MPa (180 bar).
- Fatigue pressure of 2.000.000 cycles at 0-8 MPa (0-80 bar) per NFPA T 3.10.5 R2:2000.
- By-pass valve integrated in the head setting 600 kPa (6 bar) per ISO 3968.
- Operating temperature -20 +120°C.
- Compatibility with hydraulic fluids per ISO 2943.
- Flow rate and pressure drop determined per ISO 3968 with oil kinematic viscosity 30 cSt at 40°C and density 0,875 kg/dm³.
- Filter head in tempered aluminum.
- Aluminum bowl.

Filter Elements

- Wire mesh: 30-60 micron.
- Cellulose media: 36 micron, reinforced with wire mesh.
- Synteq® synthetic media: 8-11-23 micron, reinforced with wire mesh.
- Collapse resistance 2 MPa (20 bar) per ISO 2941.

Components



	WIRE MESH MEDIA				CELLULOSE MEDIA		SYNTHETIC MEDIA						CARTRIDGE CODE
	/6		/3M		/1		/03		XP10		XP5		
	60µm		30µm		$\beta_{36\mu m(c)} \geq 1000$		$\beta_{23\mu m(c)} \geq 1000$		$\beta_{11\mu m(c)} \geq 1000$		$\beta_{8\mu m(c)} \geq 1000$		
Family	RMF		RMF		RMF		RMF		RMF		RMF		
FM140	50	P171706	50	P171705	40	P171704	40	P171703	40	P171702	40	P171701	CM140
FM180	80	P171712	80	P171711	60	P171710	60	P171709	60	P171708	60	P171707	CM180

RMF = Recommended Maximum Flow in liters/minute with use of standard housing.

Indicator Choices

Indicator	Kind		Reference Drawing	Setting (bar)	Contact	Protection Class	Cable Clamp	Max. Values	Remark
P171945	Visual	Differential	H	5					
P171947	Electrical	Differential	K	5	Normally Open/ Closed	IP65	PG11	250V AC; 30 V DC; 5A res. and ind.	
P171944	Electrical	Differential	K	5	Normally Open/ Closed	IP65	PG11	250V AC; 30 V DC; 5A res. and ind.	with thermostat at min. temperature at 30°C
P761056	Electrical	Differential	I	5	Normally Open/ Closed	IP65	PG11	30 V DC; 30 V AC; 0,5 A res. and 0,2 A ind.	

MEDIUM PRESSURE FILTERS

Standard Housing	HOUSING DIMENSIONS													CARTRIDGE DIMENSIONS			POSSIBLE INDICATORS
	A	B	C	D	E	G	H	J	L	S	BPV	M	N	X	Y	Z	
		mm	mm	mm	mm	mm	mm		mm	mm	bar	predrilled holes	plugged	mm	mm	mm	
P766661	G1/2	78	60	172	17	20	38	M8x1,25	Hex27	30	6	G1/2	YES	90	43	22,2	P171945, P171947, P171944, P761056
P766660	G1/2	78	60	258	17	20	38	M8x1,25	Hex27	30	6	G1/2	YES	176	43	22,2	

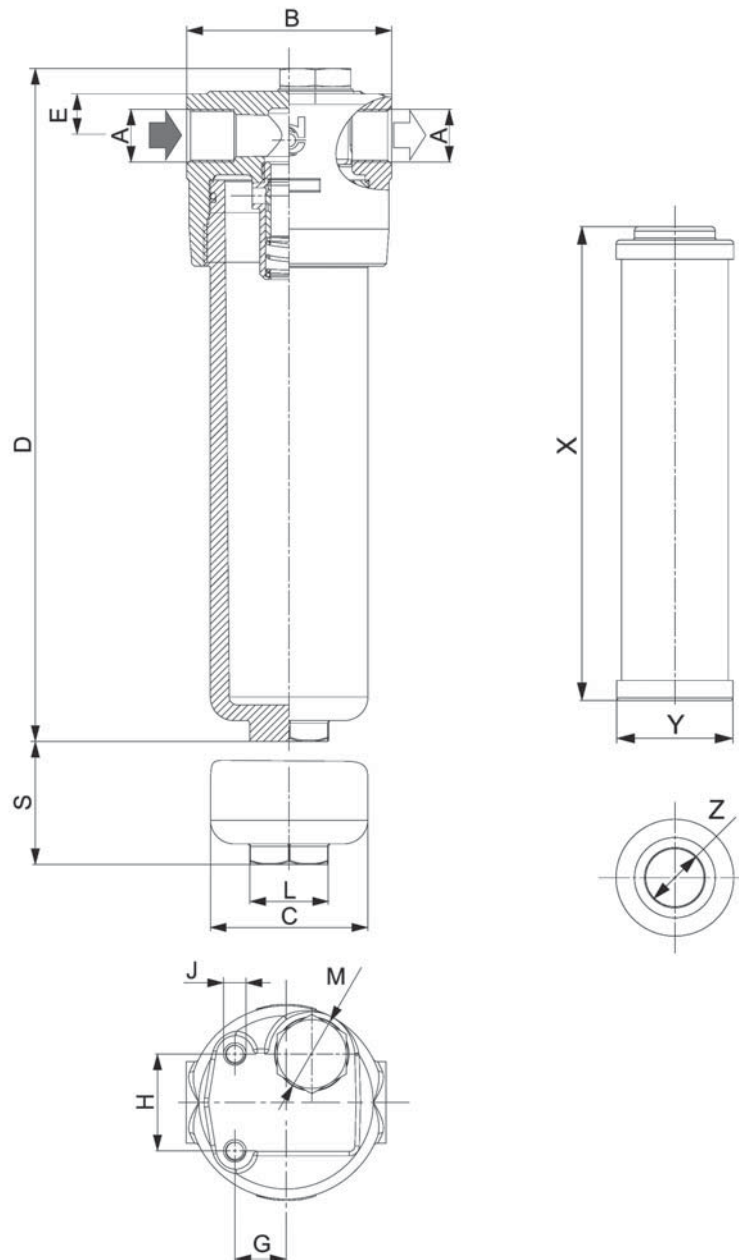

MEDIUM PRESSURE
FILTERS

Installation & Service Guidelines

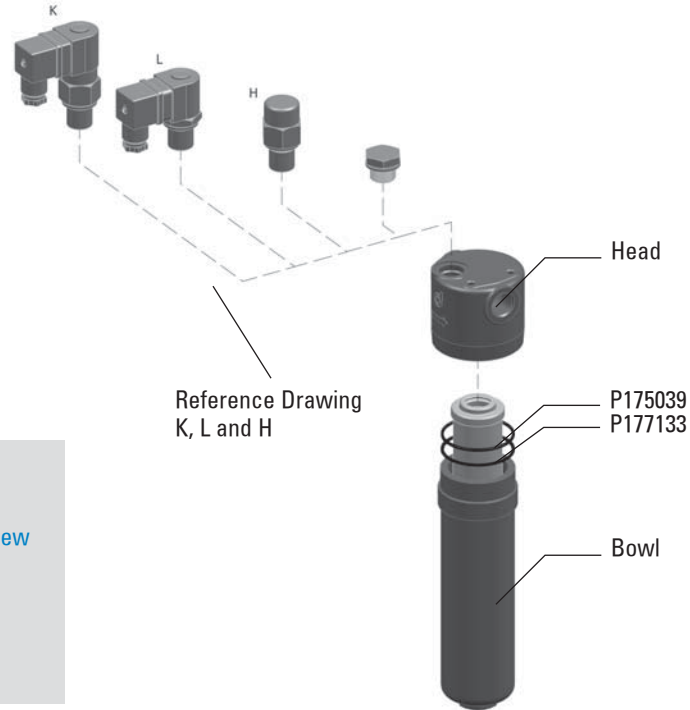

Important

- The filter head snout must be lubricated before spinning on a new filter to prevent thread damage. Heavyweight gear lube is recommended.
- Oil the O-Rings before assembly.

Performance Curves

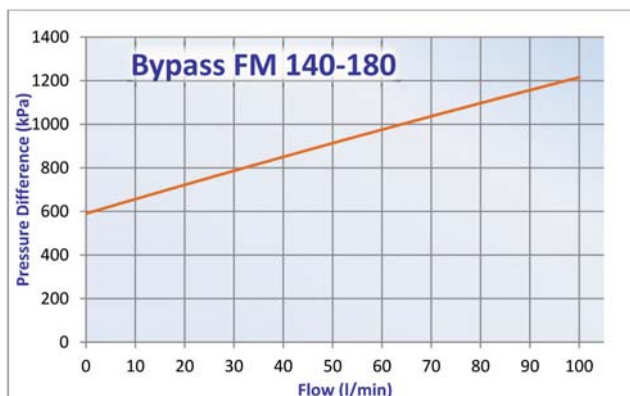
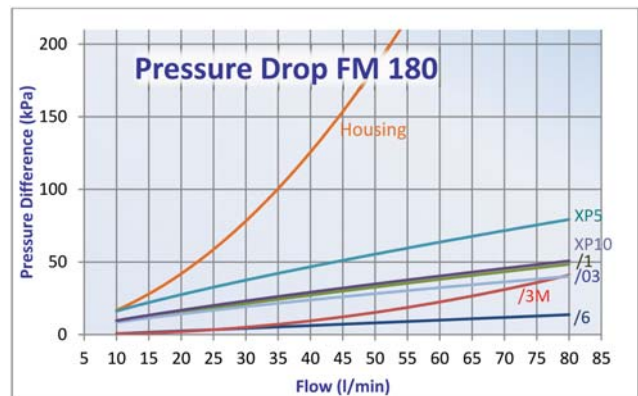
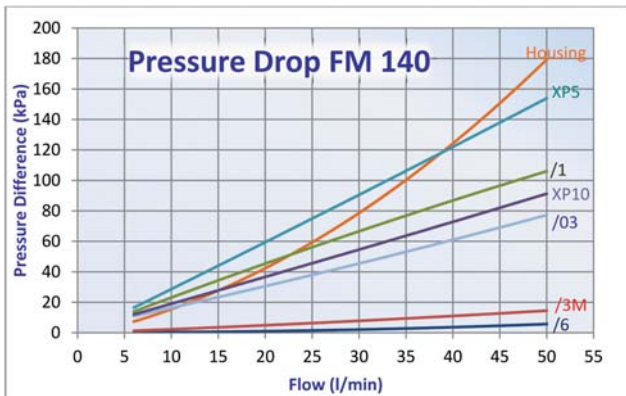



Technical Data

- Operating pressure up to 6 MPa (60 bar)
- Static pressure testing up to 6 MPa (60 bar).
- Operating temperature -20 +120°C.
- Compatibility with hydraulic fluids per ISO 2943.
- Flow rate and pressure drop determined per ISO 3968 with oil kinematic viscosity 30 cSt at 40°C and density 0,875 kg/dm³.
- Aluminum alloy head and bowl.

Filter Elements

- Wire mesh: 60 micron.
- Collapse resistance 2 MPa (20 bar) per ISO 2941.



Components

		WIRE MESH MEDIA			CARTRIDGE CODE
		/6			
		60µm			
Family	RMF	Complete Filter	Sparepart		
LC140	30	K020200	P171706	CM140	

RMF = Recommended Maximum Flow in liters/minute with use of standard housing.
Not possible to install an indicator of this filter.

Installation & Service Guidelines



Important

- The filter head snout must be lubricated before spinning on a new filter to prevent thread damage. Heavyweight gear lube is recommended.
- Oil the O-Rings before assembly.

HOUSING DIMENSIONS					
A	B	C	D	L	S
	mm	mm	mm	mm	mm
M22x1,5	75	58	145	HEX30	100

CARTRIDGE DIMENSIONS		
X	Y	Z
mm	mm	mm
44	91	23

POSSIBLE INDICATOR
none

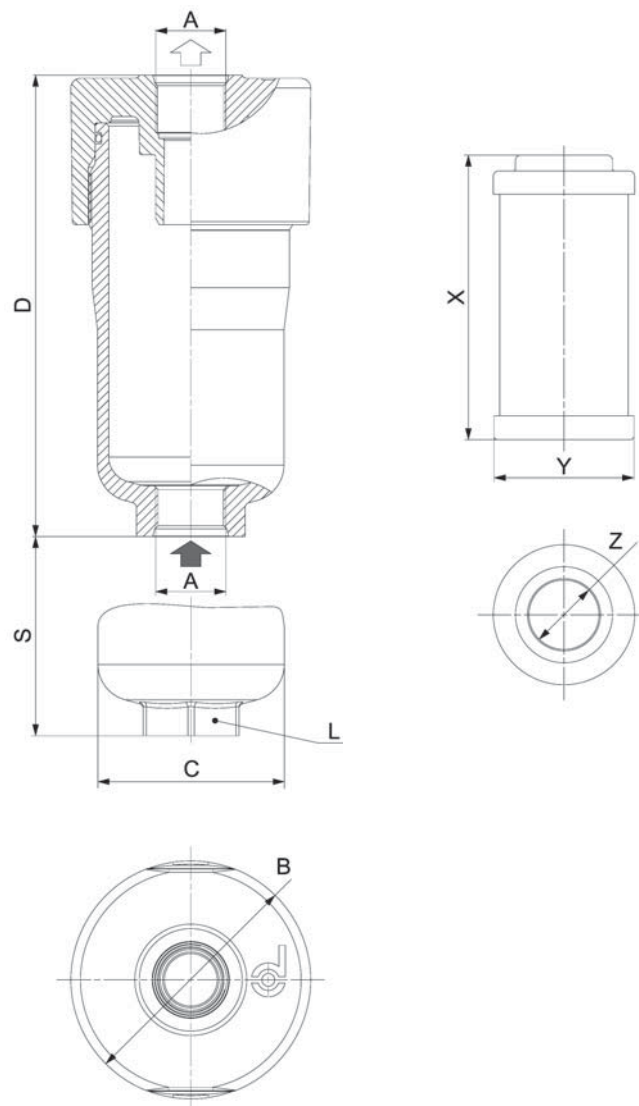

Performance Curves

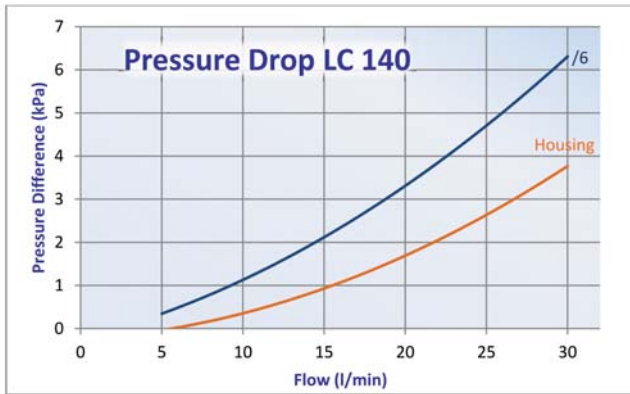



Technical Data **Filter Elements**

- Operating pressure up to:
 - FLK90 40 bar
 - FLK110 30 bar
 - FLK125 35 bar
 - Fatigue Pressure resistance according NFPA T 3.10.5.1, R2-2000.
 - FLK90 >2 million cycles (0-40 bar @ 2 Hz)
 - FLK110 >2 million cycles (0-30 bar @ 2 Hz)
 - FLK125 >2 million cycles (0-35 bar @ 2 Hz)
 - Static pressure testing up to:
 - FLK90 138 bar
 - FLK110 90 bar
 - FLK125 138 bar
 - By-pass valve setting:
 - FLK90 3.45 bar
 - FLK110 3.45 bar
 - FLK125 3.45 bar
 - Operating temperature -40 +120°C.
 - Compatibility with hydraulic fluids per ISO 2943.
 - Flow rate and pressure drop determined per ISO 3968 with oil kinematic viscosity 30 cSt at 40°C and density 0,875 kg/dm³.
- Synteq® XP media:
 - FLK90 12 micron
 - FLK110 10 micron
 - FLK125 5 micron
 - Collapse resistance per ISO 2941:
 - FLK90 10 bar
 - FLK110 10 bar
 - FLK125 15 bar

See p. 6 of this catalogue for more technical highlights about this product line.

MEDIUM PRESSURE FILTERS

Components



Family	XP12		XP10		XP5	
	Synthetic Media					
	$\beta_{15(\mu c)} \geq 1000$		$\beta_{11(\mu c)} \geq 1000$		$\beta_{9(\mu c)} \geq 1000$	
	RMF		RMF		RMF	
FLK90SA	80	P767129	60	P766987	40	P767128
FLK90SB	95	P767129	75	P766987	55	P767128
FLK90LA	135	P767131	115	P766959	95	P767130
FLK90LB	150	P767131	130	P766959	110	P767130
FLK110MC	140	P767012	120	P766813	100	P766847
FLK110MD	150	P767012	130	P766813	110	P766847
FLK110LC	180	P767011	160	P766811	140	P767010
FLK110LD	210	P767011	190	P766811	170	P767010
FLK125	320	P767106	300	P767104	280	P767084

RMF = Recommended Maximum Flow in liters/minute with use of standard housing.
 All housings are predrilled and holes are plugged, you are not obliged to install an indicator.
 The Bypass valve is installed in the head of the filter. The Cartridges have also a Bypass valve, but at a higher setpoint.

FLK 90

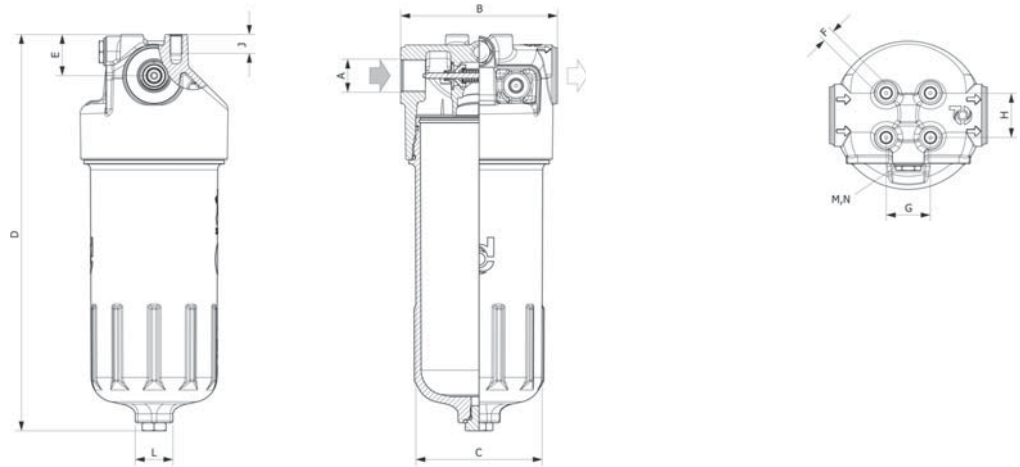

FLK 110

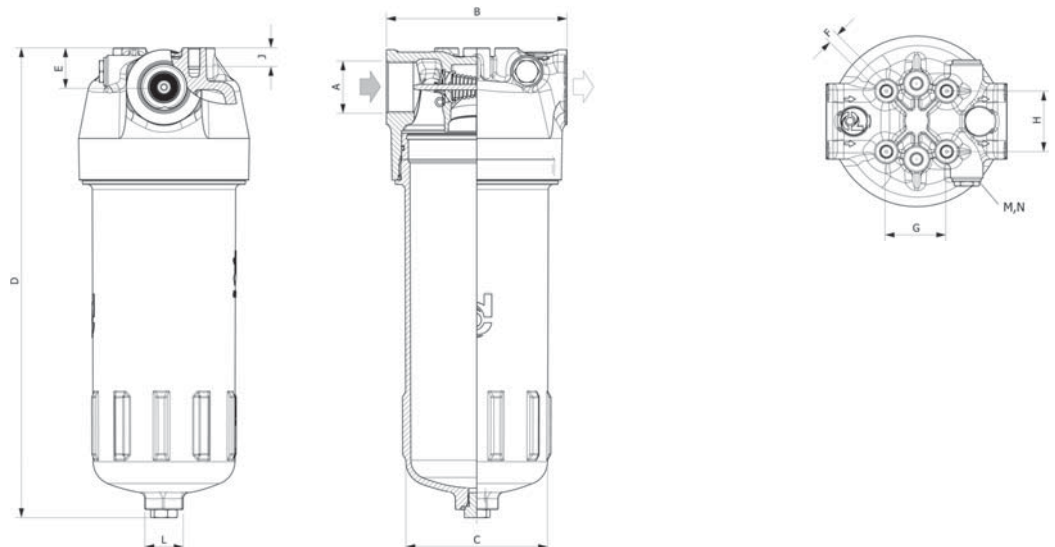

MEDIUM PRESSURE FILTERS

Head	Bowl	HOUSING DIMENSIONS													
		A	B	C	D	E	F	G	H	J	L	M	N	S	BPV
			mm	mm	mm	mm		mm	mm	mm	mm	mm	predrilled holes	plugged	mm
P766960	P766990	G3/4	125	100	215	33	M10	35	35	15	30	yes	yes	50	3,45
P766989	P766990	G1	125	100	215	33	M10	35	35	15	30	yes	yes	50	3,45
P766960	P766961	G3/4	125	100	317	33	M10	35	35	15	30	yes	yes	50	3,45
P766989	P766961	G1	125	100	317	33	M10	35	35	15	30	yes	yes	50	3,45
P766809	P766812	G1 1/4	144	113	300	31,5	M10	48	48	15	30	yes	yes	50	3,45
P766818	P766812	G1 1/2	144	113	300	31,5	M10	48	48	15	30	yes	yes	50	3,45
P766809	P766810	G1 1/4	144	113	376	31,5	M10	48	48	15	30	yes	yes	50	3,45
P766818	P766810	G1 1/2	144	113	376	31,5	M10	48	48	15	30	yes	yes	50	3,45
P767109	P767089	G2	161	124	424	46	M10	70	70	15	38	yes	yes	50	3,45

FLK 125

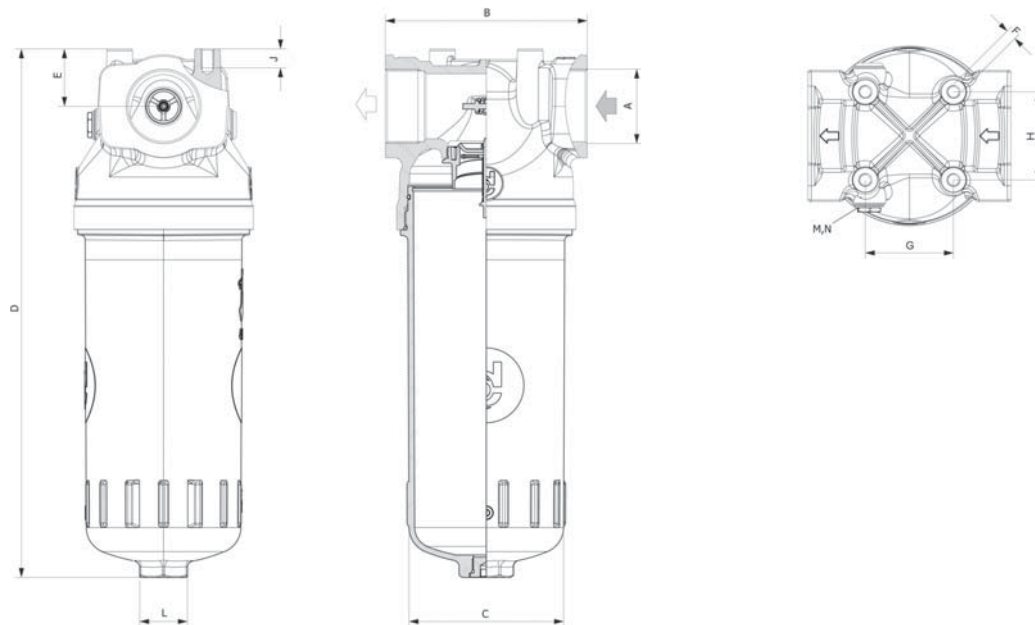

MEDIUM PRESSURE
FILTERS

Indicator Choices

Part	Kind		Reference Drawing	Setting (bar)	Contact	Protection Class	Cable Clamp	Max. Values
P763975	Electrical	Differential	B	2,75	Normally Open			6-30V DC; 0,2 A
P763976	Electrical	Differential	B	2,75	Normally Closed			6-30V DC; 0,2 A
P171087	Electrical	Differential	M	2,75	Normally Open		Packard Connector	6-30 V DC; 200 mA
P170926	Electrical	Differential	I	2,75	Normally Closed		Packard Connector	6-30 V DC; 100 mA
P173893	Electrical	Differential	P	2,75	Normally Open or Closed		3 Wires	6-30 V DC; 100 mA

Installation & Service Guidelines

FLK 90

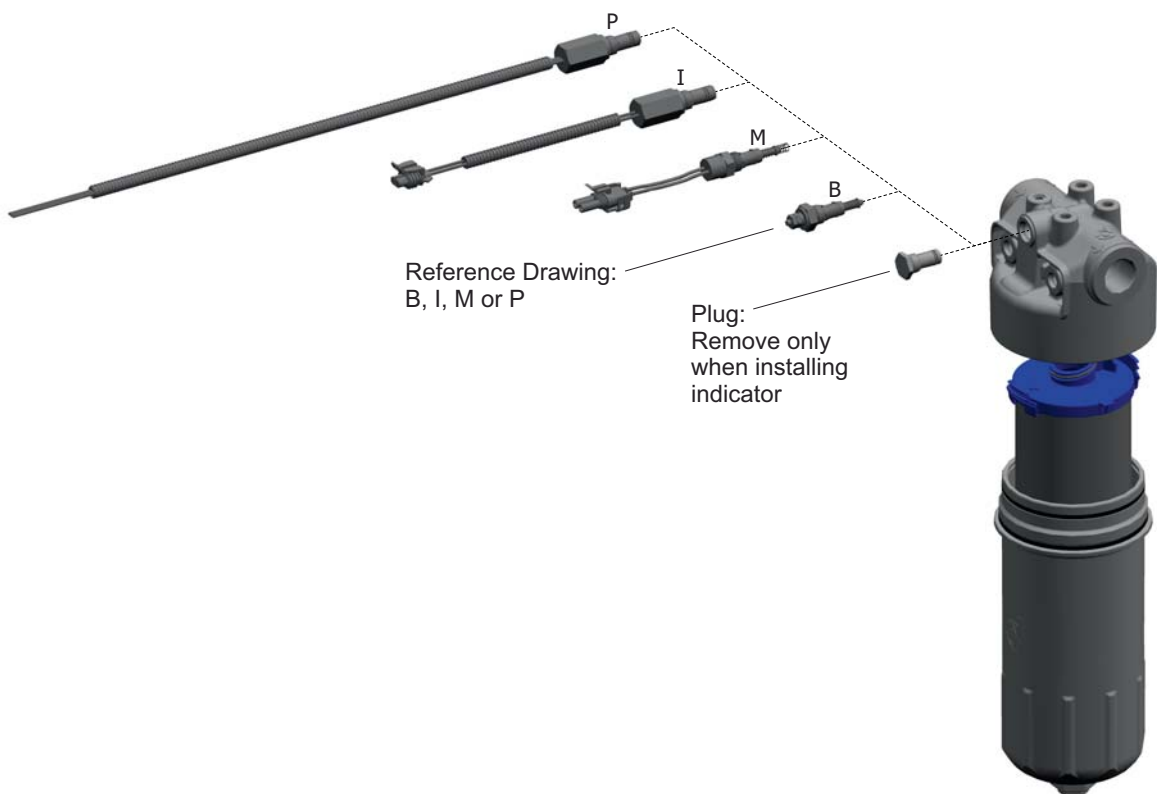

FLK 110

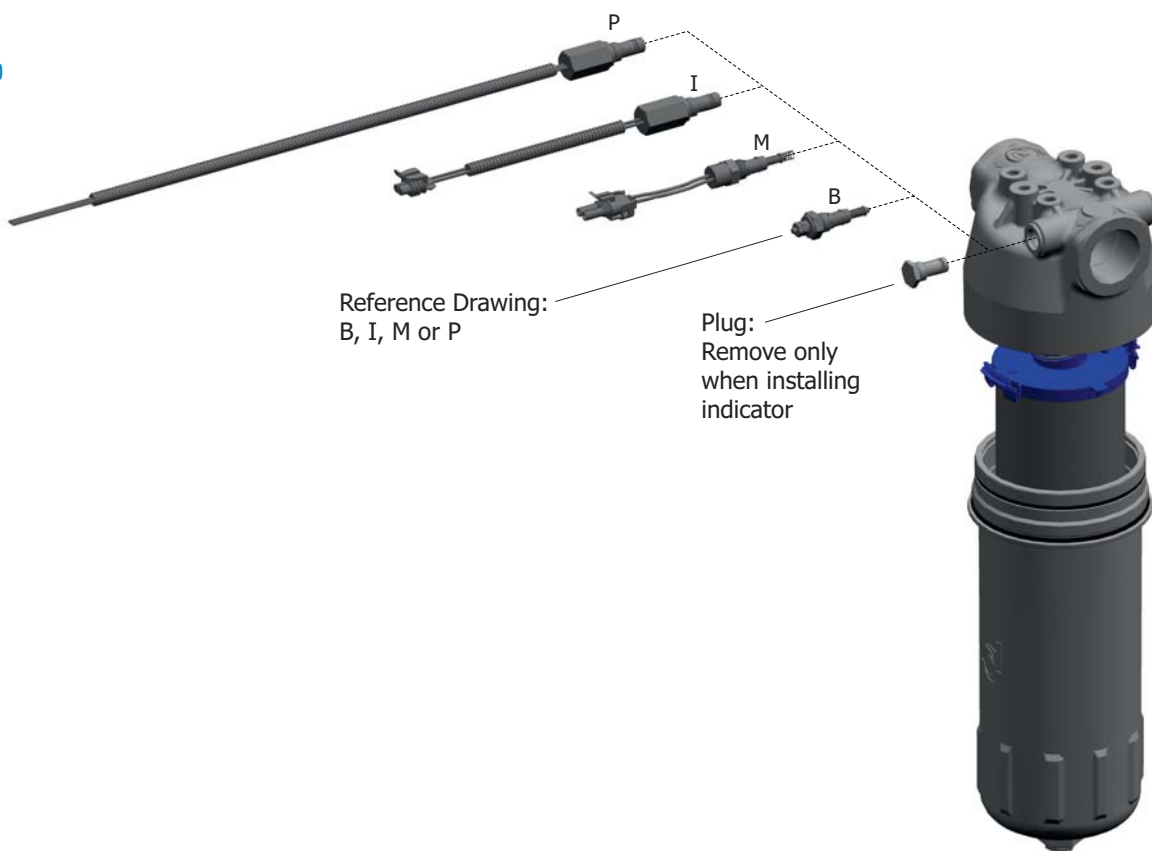

FLK 125

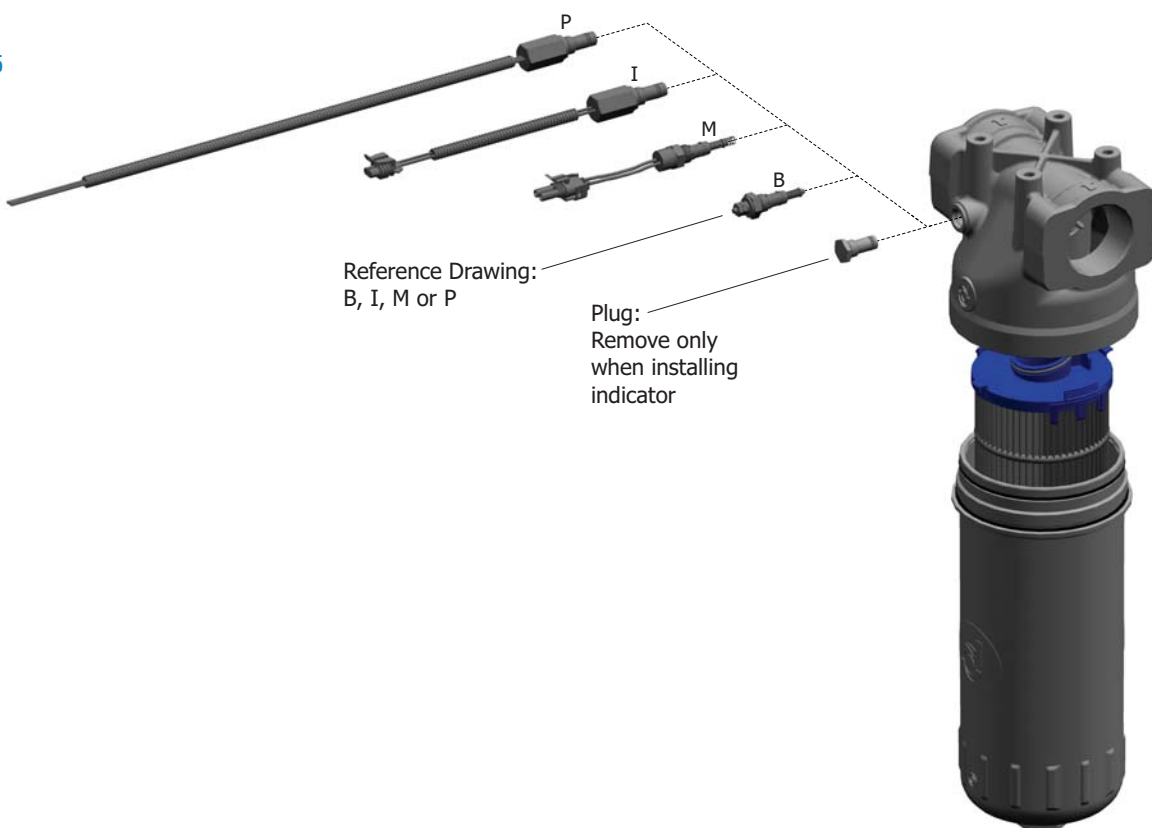

MEDIUM PRESSURE
FILTERS

Performance Curves

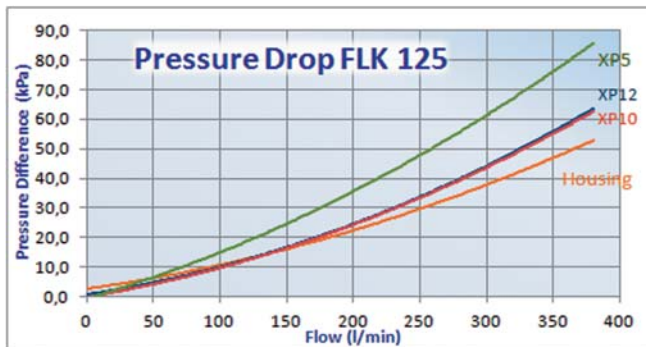
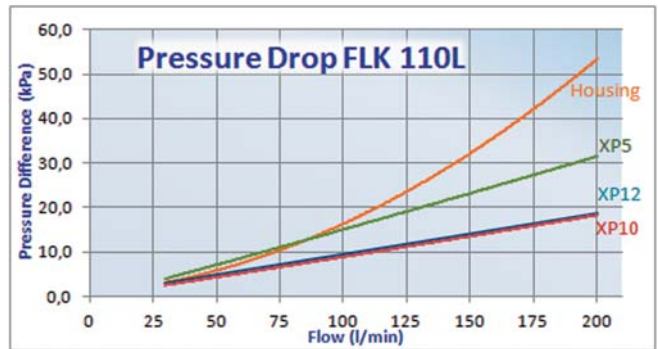
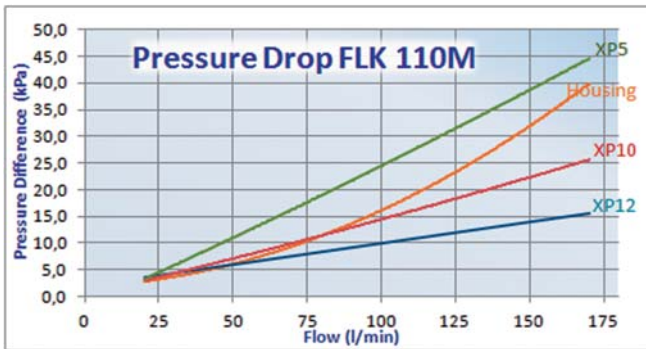
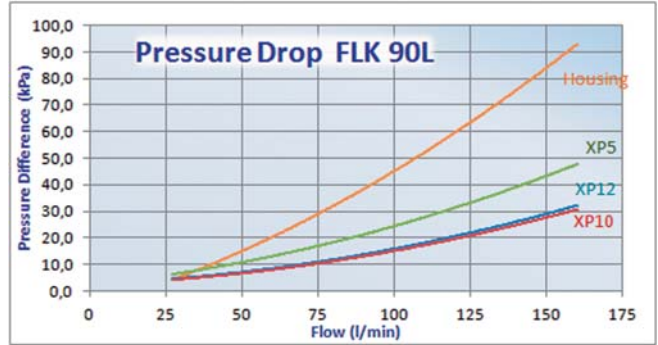
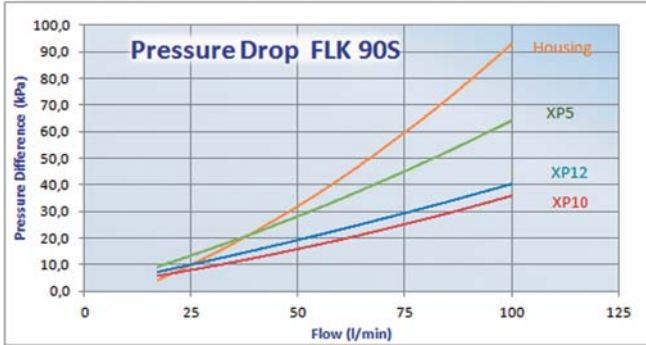

MEDIUM PRESSURE FILTERS



Mix&Match to Get What You Need

Donaldson's Mix&Match system provides the great performance and functional advantages of custom-engineered filters with the convenience and speedy delivery of in-stock parts. Choose your options and build a filter model that exactly suits your cleanliness requirements.

Technical Data

- Operating pressure up to 3,45 MPa (34,5 bar).
- Static pressure testing up to 6,9 MPa (69 bar).
- By-pass valve setting 170 kPa (1,7 bar) differential per ISO 3968.
- Available by-pass valve with setting 350 kPa (3,5 bar) differential.
- Operating temperature -20 +120°C.
- Pressure fatigue strength per NFPA T3.10.17 0 - 3,45 MPa (0-34,5 bar) for 100.000 cycles.
- Compatibility with hydraulic fluids per ISO 2943.
- Flow rate and pressure drop determined per ISO 3968 with oil kinematic viscosity 30 cSt at 40°C and density 0,875 kg/dm³.

Filter Elements

- Operating pressure up to 3,45 MPa (34,5 bar).
- Static spin-on burst resistance 6,9 MPa (69 bar).
- Element collapse resistance 2 MPa (20 bar) per ISO 2941.
- Cellulose paper: 23 micron.
- Synteq® synthetic media: 7-11-33-50 micron.
- Heavy duty steel can with die cast baffle for added strength and a special head-to-spin-on O-ring seal.
- Available intermediate length spin-on L=180 mm.



Components

Family	CELLULOSE MEDIA		SYNTHETIC MEDIA						CARTRIDGE CODE		
	#10		#20		#7		XP10			XP5	
	$\beta_{23\mu m(c)} \geq 1000$		$\beta_{50\mu m(c)} \geq 1000$		$\beta_{33\mu m(c)} \geq 1000$		$\beta_{11\mu m(c)} \geq 1000$			$\beta_{7\mu m(c)} \geq 1000$	
RMF		RMF		RMF		RMF		RMF			
HMK405	100	P163419	120	P165335	110	P164381	110	P164375	100	P165354	K405
HMK409	110	P163324	140	P165338	130	P164384	130	P164378	120	P165332	K409

RMF = Recommended Maximum Flow in liters/minute with use of standard head.
BPV = Bypass Valve Setting.

Heads Choices



Head for Family	Head	Ports	Bypass Valve Setting	Indicator Info				Snout	Mounting holes
				Drilled holes for indicator	Indicator hole plugged	Side	Indicator to use		
HMK04	P167473	1 1/16-12 UN	1,7 bar	no	-	-	none	1 3/8-12 UNF	3/8-16 UNC
	P173918	1 1/16-12 UN	3,5 bar	plugged	yes	left	P165194, P167455, P171087, P170926 or P173893	1 3/8-12 UNF	3/8-16 UNC
	P764322	1 1/16-12 UN	3,5 bar	used	-	left	P165194 (installed)	1 3/8-12 UNF	3/8-16 UNC
	P762801	1 5/16-12 UN	1,7 bar	plugged	yes	left	P162400, P163839, P171143 or P173944	1 3/8-12 UNF	M10
	P761378	1 5/16-12 UN	2,5 bar	plugged	yes	left	P162400, P163839, P171143 or P173944	1 3/8-12 UNF	M10
	P763139	1 5/16-12 UN	3,5 bar	no	-	-	none	1 3/8-12 UNF	M10
	P173438*	G 1	1,7 bar	plugged	yes	left	P162400, P163839, P171143 or P173944	1 3/8-12 UNF	M10
	P766296	G 1	1,7 bar	plugged used	yes -	left left	P162400, P163839, P171143 or P173944 P162696 (installed)	1 3/8-12 UNF	M10
	P762982	G 1	3,5 bar	plugged	yes	left	P165194, P167455, P171087, P170926 or P173893	1 3/8-12 UNF	M10
	P173132	G 1	3,5 bar	used	no	left	P165194 (installed)	1 3/8-12 UNF	M10
	P760924	G 1	3,5 bar	used	-	left	P167455 (installed)	1 3/8-12 UNF	M10
	P173386*	G 3/4	1,7 bar	plugged	yes	left	P162400, P163839, P171143 or P173944	1 3/8-12 UNF	M10
	P762554	G 3/4	1,7 bar	no	-	-	none	1 3/8-12 UNF	M10
	P766295	G 3/4	1,7 bar	used	-	left	P162696 (installed)	1 3/8-12 UNF	M10
	P173385	G 3/4	3,5 bar	no	-	-	none	1 3/8-12 UNF	M10
	P175029	G 3/4	no opening	used	-	left	P165194 (installed)	1 3/8-12 UNF	M10

HMK 04 – Duramax Filters aren't delivered with drilled holes for indicators or bypass valve, heads are.
Unless otherwise mentioned, the usage of indicators is mandatory, because the drilled holes for indicators are not plugged.

* Standard Head

Standard Head	HEAD DIMENSIONS									SPIN-ON DIMENSIONS		
	A	B	C	D	E	F	G	S	BPV	X	Y	Z
		mm	mm	mm		mm	mm	mm	bar	mm	mm	
P173386	G3/4	98	34	64	M10	35	35	22	1,7	152	94	1 3/8-12 UNF 2B
P173438	G1	98	34	64	M10	35	35	22	1,7	240	94	1 3/8-12 UNF 2B

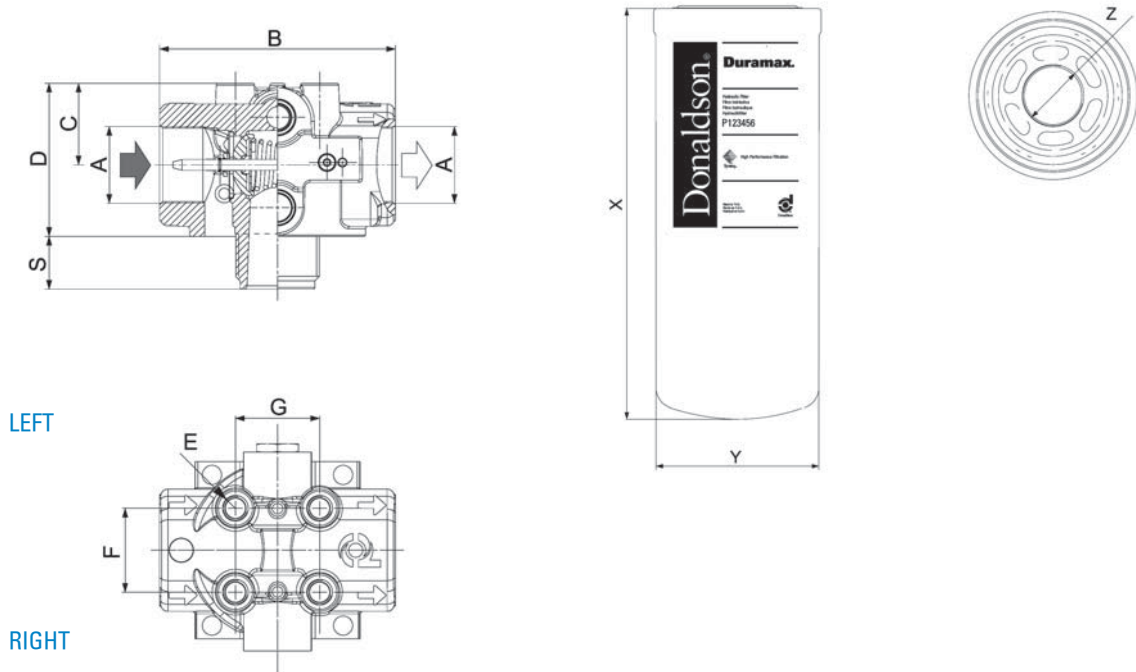

Indicator Choices

Indicator	Kind		Reference Drawing	Setting (bar)	Contact	Cable Clamp	Max. Values
P162400	Electrical	Differential	B	1,25	Normally Open		6-30 V DC; 200 mA
P163839	Electrical	Differential	B	1,25	Normally Closed		6-30 V DC; 200 mA
P165194	Electrical	Differential	B	2,75	Normally Open		30 V DC; 0,2A
P167455	Electrical	Differential	B	2,75	Normally Closed		30 V DC; 0,2A
P162696	Visual	Differential	D	1,7			
P167580	Visual	Differential	D	3,4			
P170926	Electrical	Differential	I	2,75	Normally Closed	Packard Connector	6-30 V DC; 100 mA
P171087	Electrical	Differential	M	2,75	Normally Open	Packard Connector	6-30 V DC; 200 mA
P171143	Electrical	Differential	J	1,25	Normally Open	Canon Connector	6-30 V DC; 200 mA
P173944	Electrical	Differential	Q	1,4	Normally Open or Closed	3 Wires	24V DC; 110 V AC; 2A
P173893	Electrical	Differential	P	2,75	Normally Open or Closed	3 Wires	6-30 V DC; 100 mA

MEDIUM PRESSURE FILTERS

Installation & Service Guidelines

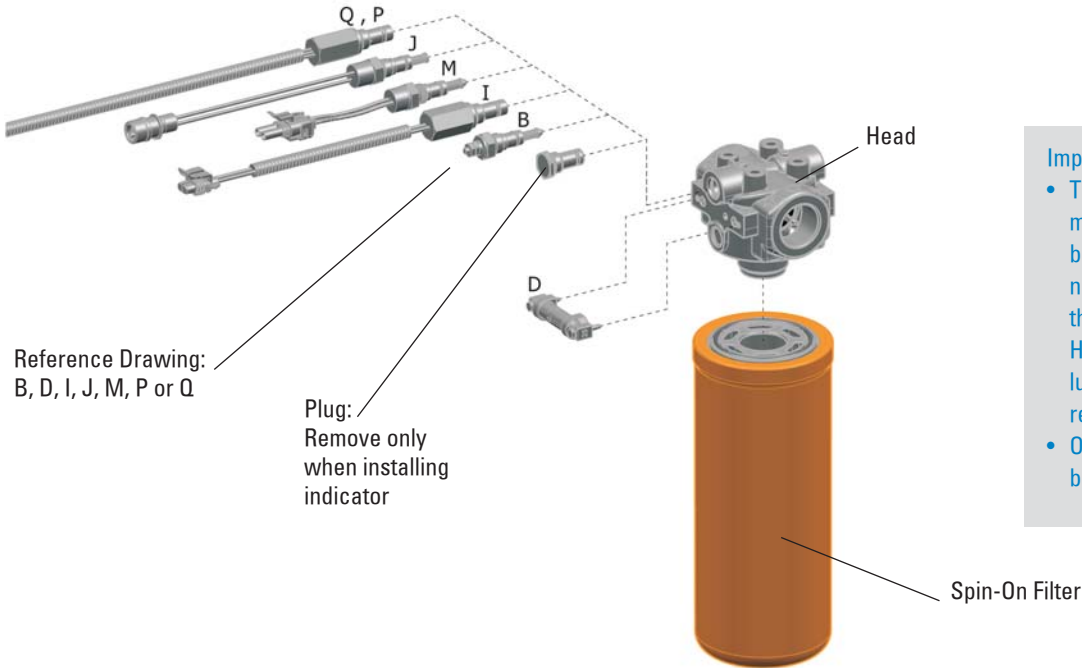

Important

- The filter head snout must be lubricated before spinning on a new filter to prevent thread damage. Heavyweight gear lube is recommended.
- Oil the O-Rings before assembly.

Performance Curves

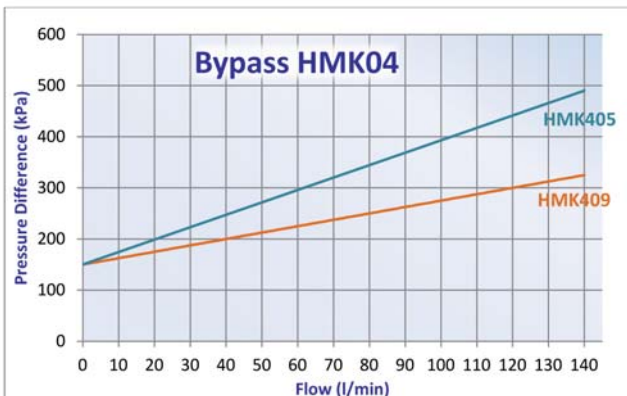
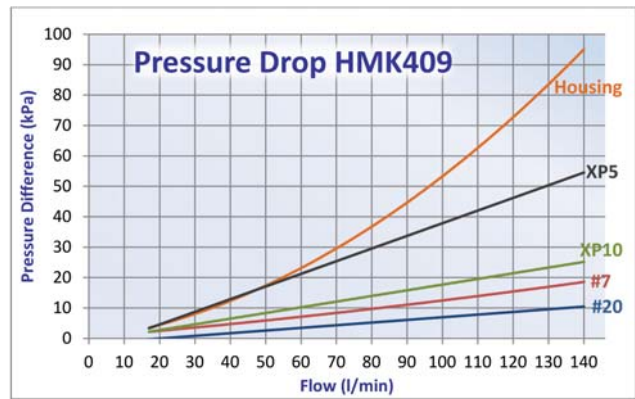
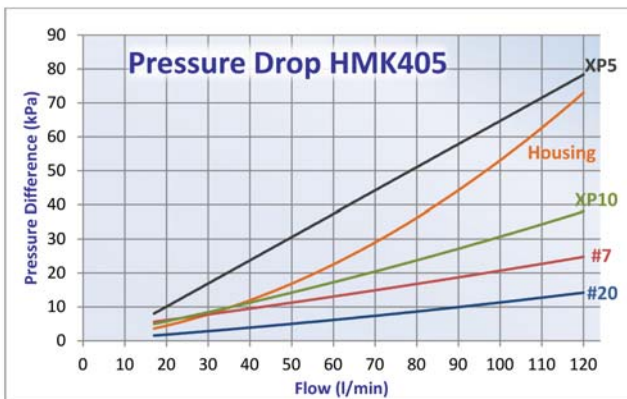



Mix&Match to Get What You Need

Donaldson's Mix&Match system provides the great performance and functional advantages of custom-engineered filters with the convenience and speedy delivery of in-stock parts. Choose your options and build a filter model that exactly suits your cleanliness requirements.

Technical Data

- Operating pressure up to 2,4 MPa (24 bar).
- Static pressure testing up to 5,5 MPa (55 bar).
- By-pass valve setting 170 kPa (1,7 bar) differential per ISO 3968.
- Available by-pass valve with setting 350 kPa (3,5 bar) differential.
- Operating temperature -20 +120°C.
- Pressure fatigue strength per NFPA T3.10.17 0-2,4 MPa (0-24 bar) for 100.000 cycles.
- Compatibility with hydraulic fluids per ISO 2943.
- Flow rate and pressure drop determined per ISO 3968 with oil kinematic viscosity 30 cSt at 40°C and density 0,875 kg/dm³.

Filter Elements

- Operating pressure up to 2,4 MPa (24 bar).
- Static spin-on burst resistance 5,5 MPa (55 bar).
- Element collapse resistance 1,4 MPa (14 bar) per ISO 2941.
- Cellulose paper: 23 micron.
- Synteq® synthetic media: 7-11-33-50 micron.
- Heavy duty steel can with die cast baffle for added strength and a special head-to-spin-on O-ring seal.
- Available intermediate length spin-on L=200 mm.



Components

	CELLULOSE MEDIA		SYNTHETIC MEDIA								CARTRIDGE CODE
	#10		#20		#7		XP10		XP5		
	$\beta_{23\mu m(c)} \geq 1000$		$\beta_{50\mu m(c)} \geq 1000$		$\beta_{33\mu m(c)} \geq 1000$		$\beta_{11\mu m(c)} \geq 1000$		$\beta_{7\mu m(c)} \geq 1000$		
Family	RMF		RMF		RMF		RMF		RMF		
HMK513	160	P165705	200	P165672	180	P165569	170	P165659	160	P165675	K513

RMF = Recommended Maximum Flow in liters/minute with use of standard head.
BPV = Bypass Valve Setting.

Heads Choices



Head for Family	Part	Ports	Bypass Valve Setting	Indicator Info			Snout	Mounting holes
				Drilled holes for indicator	Side	Indicator to use		
K513	P175095	1 5/8-12 UN	3,5 bar	plugged	left	P165194, P167455, P171087, P170926 or P173893	1 3/4-12 UN	M10
	P173448	G 1 1/4	1,7 bar	plugged used	left left	P162400, P163839, P171143 or P173944 P162696 (installed)	1 3/4-12 UN	M10
	P766297*	G 1 1/4	1,7 bar	no	-	none	1 3/4-12 UN	M10
	P766298	G 1 1/4	1,7 bar	used	left	P162696 (installed)	1 3/4-12 UN	M10
	P766299	G 1 1/4	1,7 bar	plugged	left	P162400, P163839, P171143 or P173944	1 3/4-12 UN	M10
	P761446	G 1 1/4	3,5 bar	used	left	P165194 (installed)	1 3/4-12 UN	M10

HMK 05 – Duramax Filters aren't delivered with drilled holes for indicators or bypass valve, heads are.
Unless otherwise mentioned, the usage of indicators is mandatory, because the drilled holes for indicators are not plugged.

* Standard Head

Standard Head	HEAD DIMENSIONS									SPIN-ON DIMENSIONS		
	A	B	C	D	E	F	G	S	BPV	X	Y	Z
		mm	mm	mm		mm	mm	mm	bar	mm	mm	
P766297	G1 1/4	121	39	72,6	M10	48	48	21	1,7	295	117	1 3/4-12 UNF 2B

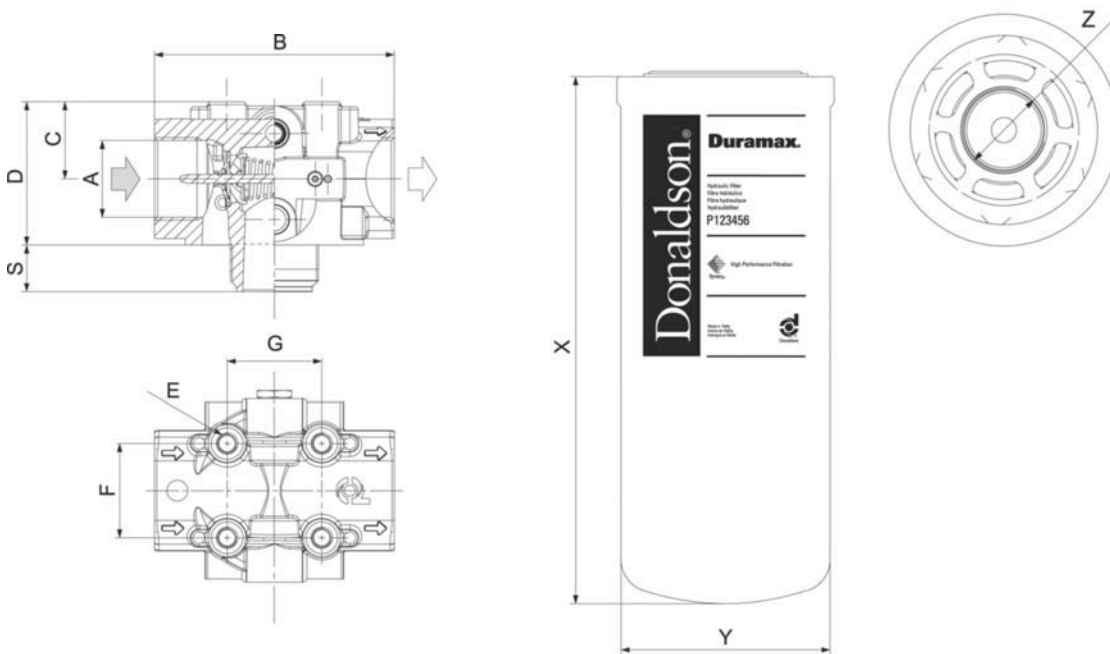

Indicator Choices

Indicator	Kind		Reference Drawing	Setting (bar)	Contact	Cable Clamp	Max. Values
P162400	Electrical	Differential	B	1,25	Normally Open		6-30 V DC; 200 mA
P163839	Electrical	Differential	B	1,25	Normally Closed		6-30 V DC; 200 mA
P165194	Electrical	Differential	B	2,75	Normally Open		30 V DC; 0,2A
P167455	Electrical	Differential	B	2,75	Normally Closed		30 V DC; 0,2A
P162696	Visual	Differential	D	1,7			
P167580	Visual	Differential	D	3,4			
P170926	Electrical	Differential	I	2,75	Normally Closed	Packard Connector	6-30 V DC; 100 mA
P171087	Electrical	Differential	M	2,75	Normally Open	Packard Connector	6-30 V DC; 200 mA
P171143	Electrical	Differential	J	1,25	Normally Open	Canon Connector	6-30 V DC; 200 mA
P173944	Electrical	Differential	Q	1,4	Normally Open or Closed	3 Wires	24V DC; 110 V AC; 2A
P173893	Electrical	Differential	P	2,75	Normally Open or Closed	3 Wires	6-30 V DC; 100 mA

MEDIUM PRESSURE FILTERS

Installation & Service Guidelines

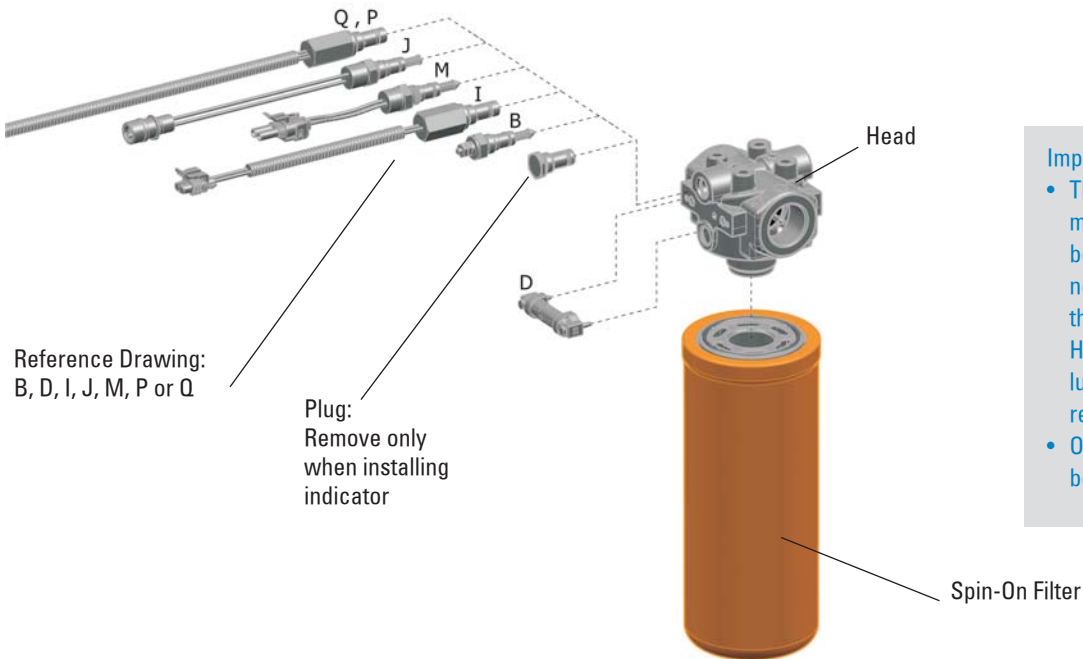

Important

- The filter head snout must be lubricated before spinning on a new filter to prevent thread damage. Heavyweight gear lube is recommended.
- Oil the O-Rings before assembly.

Performance Curves

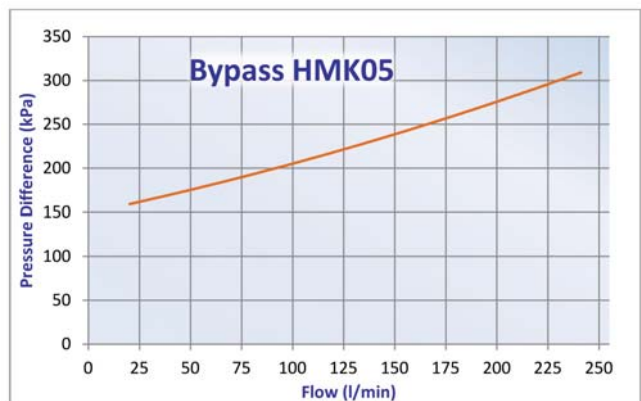
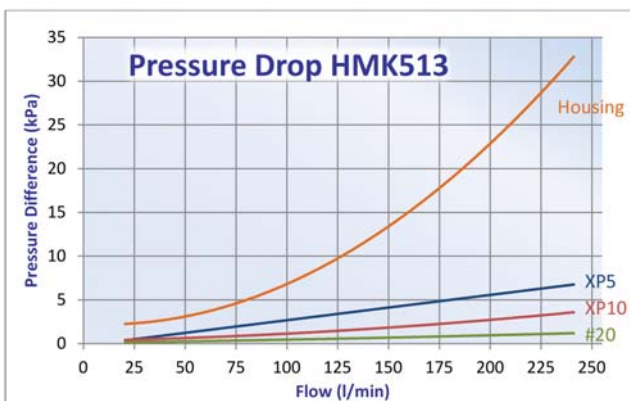

MEDIUM PRESSURE FILTERS



Mix&Match to Get What You Need

Donaldson's Mix&Match system provides the great performance and functional advantages of custom-engineered filters with the convenience and speedy delivery of in-stock parts. Choose your options and build a filter model that exactly suits your cleanliness requirements.

Technical Data

- Operating pressure up to 42 MPa (420 bar).
- Static pressure testing up to 63 MPa (630 bar).
- Fatigue pressure of 2.000.000 cycles at 0-30 MPa (0-300 bar) per NFPA T 3.10.5.1, R2-2000.
- By-pass valve setting 600 kPa (6 bar) per ISO 3968.
- Operating temperature -20 +120°C.
- Compatibility with hydraulic fluids per ISO 2943.
- Flow rate and pressure drop per ISO 3968 with oil kinematic viscosity 30 cSt at 40°C and density 0,875 kg/dm³.
- Filter head casting in spheroidal cast iron.
- Extruded steel bowl.

Filter Elements

- Synteq® synthetic media: 6-8-11-23 micron, reinforced with wire mesh.
- Collapse resistance 2 MPa (20 bar) per ISO 2941.
- Available high collapse 21 MPa (210 bar) – on customer's request.



Components

		SYNTHETIC MEDIA								CARTRIDGE CODE
		/03		XP10		XP5		/00		
		$\beta_{23\mu m(c)} \geq 1000$		$\beta_{11\mu m(c)} \geq 1000$		$\beta_{9\mu m(c)} \geq 1000$		$\beta_{9\mu m(c)} \geq 1000$		
Family	Collapse	RMF		RMF		RMF		RMF		
AP358	Standard	30	P171715	30	P171714	20	P171713	20	P761392	CM230
	High		on request		P176939		P173106		on request	CM231
AP359	Standard	50	P165136	50	P165006	40	P165041	40	P169429	CM250
	High		on request		P167181		P176613		on request	CM251
AP360	Standard	90	P165138	90	P165015	70	P165043	70	P167838	CM290
	High		on request		P167183		P176616		on request	CM291

RMF = Recommended Maximum Flow in liters/minute with use of standard housing.

BPV = Bypass Valve Setting.

High Collapse elements are non-stock items, request your sales contact for offer and lead-time.

Other medias available on request.

Indicator Choices

Part	Kind		Reference Drawing	Setting (bar)	Contact	Protection Class	Cable Clamp	Max. Values	Remark
P171945	Visual	Differential	H	5					
P171947	Electrical	Differential	K	5	Normally Open/Closed	IP65	PG11	250V AC: 30 VDC; 5A res. and ind.	
P171944	Electrical	Differential	K	5	Normally Open/Closed	IP65	PG11	250V AC: 30 VDC; 5A res. and ind.	with thermostat at min. temperature at 30°C
P761056	Electrical	Differential	L	5	Normally Open/Closed	IP65	PG11	30 V DC; 30 V AC; 0,5 A res. and 0,2 A ind.	

HIGH PRESSURE FILTERS



Standard Housing	HOUSING DIMENSIONS													CARTRIDGE DIMENSIONS			POSSIBLE INDICATOR
	A	B	C	D	E	F	H	J	L	M	N	S	BPV	X	Y	Z	
		mm	mm	mm	mm	mm	mm		mm	predrilled holes	plugged	mm	bar	mm	mm	mm	
P766377	G1/2	85	70	197	23	9	46	M8	Hex30	G1/2	yes	40	6	87	46	25,4	P171945 P171947 P171944 P761056
P766378	G1/2	85	70	223	23	9	46	M8	Hex30	G1/2	yes	40	6	113	46	25,4	
P766379	G3/4	85	70	324	23	9	46	M8	Hex30	G1/2	yes	40	6	280	46	25,4	

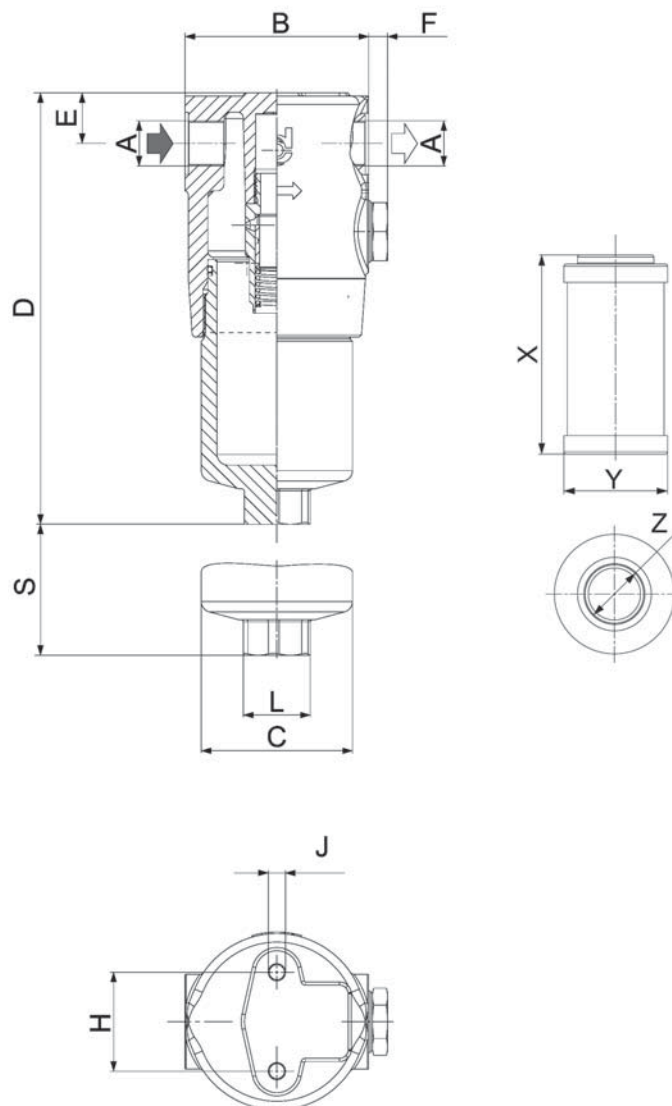

HIGH PRESSURE
FILTERS

Installation & Service Guidelines

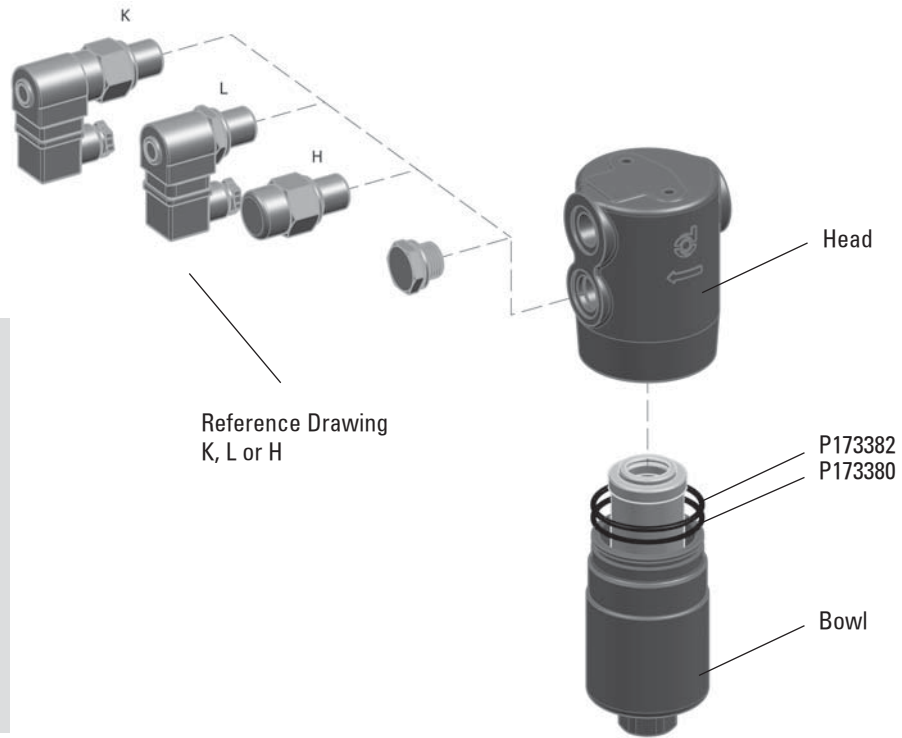

Important

- The bowl thread must be lubricated before spinning on the head to prevent thread damage. Heavyweight gear lube is recommended.
- Oil the O-Rings before assembly.

Performance Curves

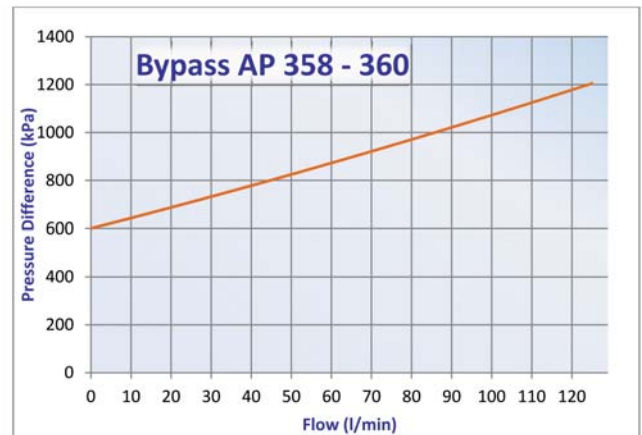
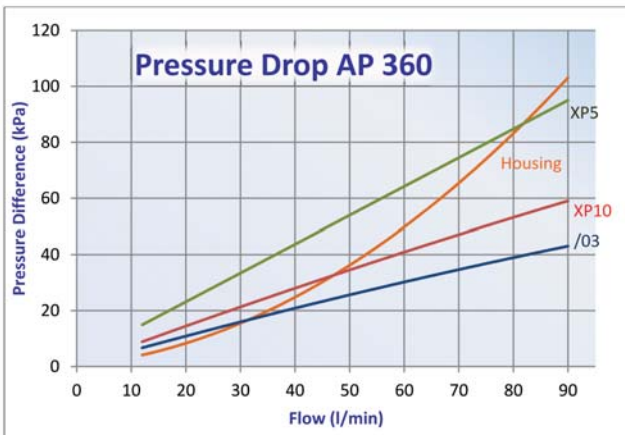
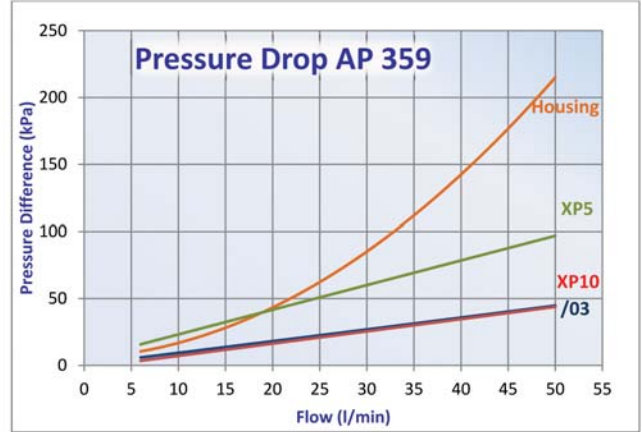
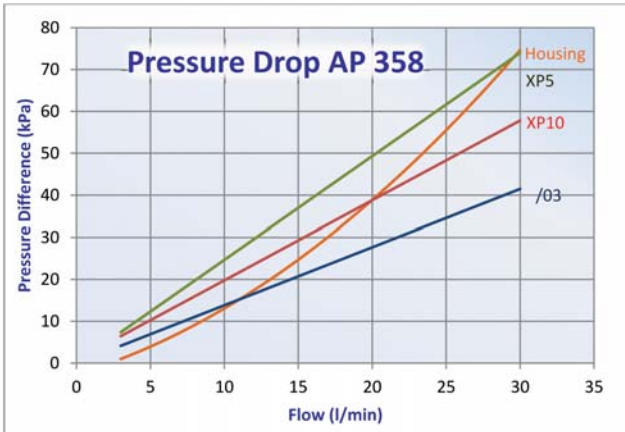

HIGH PRESSURE
FILTERS

FPK02&04-AP220

FPK02-AP280

FPK03&04-AP420

FMK-FM

FCK-LC



Open empty housing
in correct order



Remove carton ring
before use



Check if O-ring between
lid and housing is installed and intact



Check if O-Ring on cartridge is installed and
intact

For FK:
Mount O-ring over stud



For Low Pressure cartridges:
Mount spring on cartridge



Mount element in
housing



For Combo 120:
Align arrows as shown



Assemble lid on housing



Assemble bolts and
screws in correct order



Tighten screws, bolts or lid until thread ends
For spin-ons: hand tighten until contact
between O-ring and head is made; and then
continue by hand as indicated on spin-on



Degrease surface where sparepart sticker
will be mounted
Only for cartridge type filters



Sparepart sticker in each sparepart box



Fix sparepart sticker in area indicated –
Ready!



Do not forget seals





Mix&Match to Get What You Need

Donaldson's Mix&Match system provides the great performance and functional advantages of custom-engineered filters with the convenience and speedy delivery of in-stock parts. Choose your options and build a filter model that exactly suits your cleanliness requirements.

Technical Data

- Operating pressure
AP 221-222: Up to 42 Mpa (420 bar)
AP 223-224-225: Up to 30 Mpa (300 bar) .
- Static pressure testing
AP 221-222: Up to 63 MPa (630 bar)
AP 223-224-225: Up to 45 Mpa (450 bar) .
- Fatigue pressure of 2.000.000 cycles at 0-30 MPa (0-300 bar) per NFPA T3.10.5.1 R2-2000.
- By-pass valve setting:
AP 221-222: 350 kPa (3,5 bar)
AP 223-224-225: 600 kPa (6 bar) ,
per ISO 3968.
- Operating temperature -20 +120°C.
- Compatibility with hydraulic fluids per ISO 2943.
- Flow rate and pressure drop per ISO 3968
with oil kinematic viscosity 30 cSt at 40°C
and density 0,875 kg/dm³.
- Filter head casting in spheroidal cast iron.
- Extruded steel bowl.

Filter Elements

- Synteq® synthetic media: 8-11-23 micron,
reinforced with wire mesh.
- Collapse resistance 2 MPa (20 bar) per ISO 2941.
- Available high collapse 21 MPa (210 bar)
– on customer's request.

Components



		SYNTHETIC MEDIA						CARTRIDGE CODE
		/03		XP10		XP5		
		$\beta_{25(\mu m)} \geq 1000$		$\beta_{11(\mu m)} \geq 1000$		$\beta_{8(\mu m)} \geq 1000$		
Family	Collapse	RMF		RMF		RMF		
AP221	Standard	50	P169797	40	P169447	30	P169446	AP472
	High		on request		P167413		P176637	AP572
AP222	Standard	90	P169450	80	P169449	70	P169798	AP473
	High		on request		P176641		P176640	AP573
AP223	Standard	180	P164172	150	P164164	120	P164592	AP474
	High		on request		P176644		P176643	AP574
AP224	Standard	350	P164174	300	P164166	250	P164594	AP475
	High		P176647		P167186		P176646	AP575
AP225	Standard	450	P164176	400	P164168	350	P164596	AP476
	High		P167412		P176650		P176649	AP576

RMF = Recommended Maximum Flow in liters/minute with use of standard housing.
 BPV = Bypass Valve Setting
 High Collapse elements are non-stock items, request your sales contact for offer and lead-time.
 S= Service Clearance

Alternative Housing Choices



Family	Alternative Housing (see thread for indicator)	DIMENSIONS HOUSING													POSSIBLE INDICATOR	
		A	B	C	D	E	F	G	H	J	L	M	N	S		BPV
		mm	mm	mm	mm	mm	mm	mm	mm	mm	mm	predilled holes	plugged	mm		bar
AP221	P766380	G1/2	85	70	200	34	27,5	60,5	52,5	M10	Hex30	9/16-18 UNF	yes	40	3,5	P763975 P763976 P171087
AP222	P766381	G3/4	85	70	310	34	27,5	60,5	52,5	M10	Hex30	9/16-18 UNF	yes	40	3,5	
AP223	P766387	G1 1/4	140	105	252,5	36,5	28,5	94	57	M12	Hex30	G1/2	yes	47	3,5	P761058 P761057
AP224	P766388	G1 1/4	140	105	345,5	36,5	28,5	94	57	M12	Hex30	G1/2	yes	47	3,5	
AP225	P766389	G1 1/2	140	105	467,5	36,5	28,5	94	57	M12	Hex30	G1/2	yes	47	3,5	

HIGH PRESSURE FILTERS



Standard Housing without Cartridge	HOUSING DIMENSIONS														CARTRIDGE DIMENSIONS			POSSIBLE INDICATOR
	A	B	C	D	E	F	G	H	J	L	M	N	S	BPV	X	Y	Z	
		mm	mm	mm	mm	mm	mm	mm		mm	predilled holes	plugged	mm	bar	mm	mm	mm	
P766385	G1/2	85	70	200	34	27,5	60,5	52,5	M10	Hex30	G1/2	yes	40	3,5	113	50	24	P761058 P761057
P766386	G3/4	85	70	310	34	27,5	60,5	52,5	M10	Hex30	G1/2	yes	40	3,5	207	50	24	
P766382	G1 1/4	140	105	252,5	36,5	28,5	94	57	M12	Hex30	9/16-18 UNF	yes	47	6	115	78	43	P763975 P763976 P171087
P766383	G1 1/4	140	105	345,5	36,5	28,5	94	57	M12	Hex30	9/16-18 UNF	yes	47	6	208	78	43	
P766384	G1 1/2	140	105	467,5	36,5	28,5	94	57	M12	Hex30	9/16-18 UNF	yes	47	6	330	78	43	

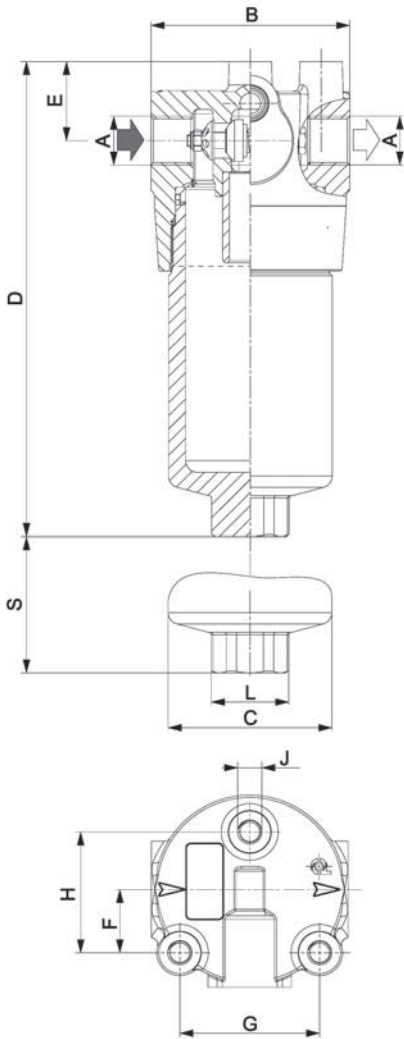

AP 221-222

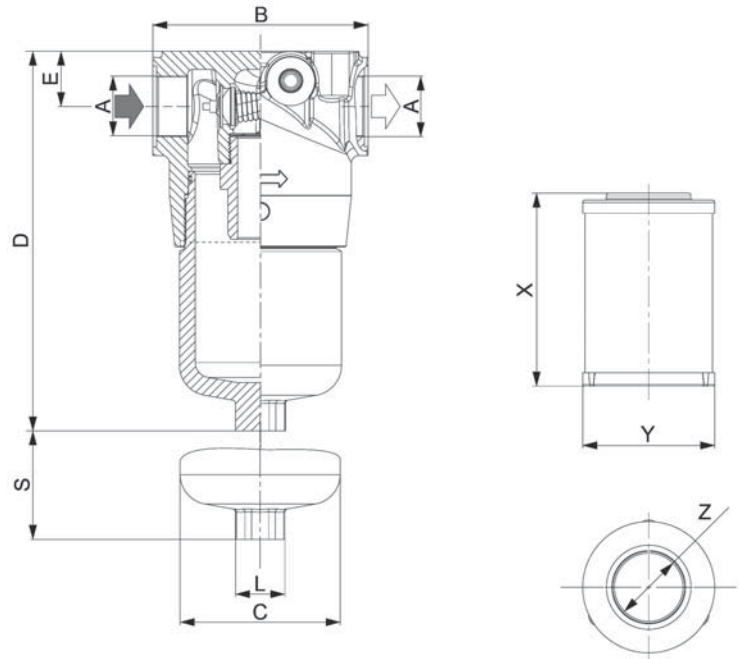

AP 223-224-225

HIGH PRESSURE
FILTERS

Indicator Choices

Part	Kind		Reference Drawing	Setting (bar)	Contact	Protection Class	Cable Clamp	Max. Values
P763975	Electrical	Differential	B	2,75	Normally Open			6-30V DC; 0,2 A
P763976	Electrical	Differential	B	2,75	Normally Closed			6-30V DC; 0,2 A
P761058	Visual	Differential	H	3				
P761057	Electrical	Differential	L	3	Normally Open/Closed	IP65	PG11	30 V DC; 0,5 A res. and 0,2 A ind.
P171087	Electrical	Differential	M	2,75	Normally Open		Packard Connector	6-30 V DC; 200 mA

Installation & Service Guidelines

AP 221-222

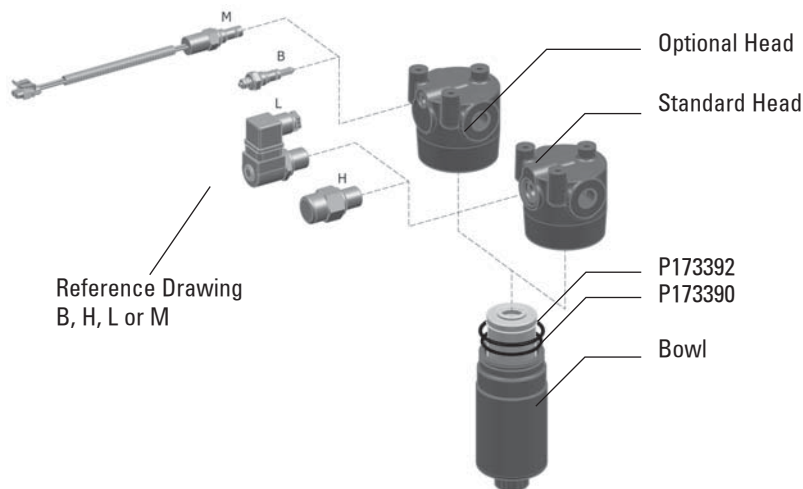

Important

- The bowl thread must be lubricated before spinning on the head to prevent thread damage. Heavyweight gear lube is recommended.
- Oil the O-Rings before assembly.

AP 223-224-225

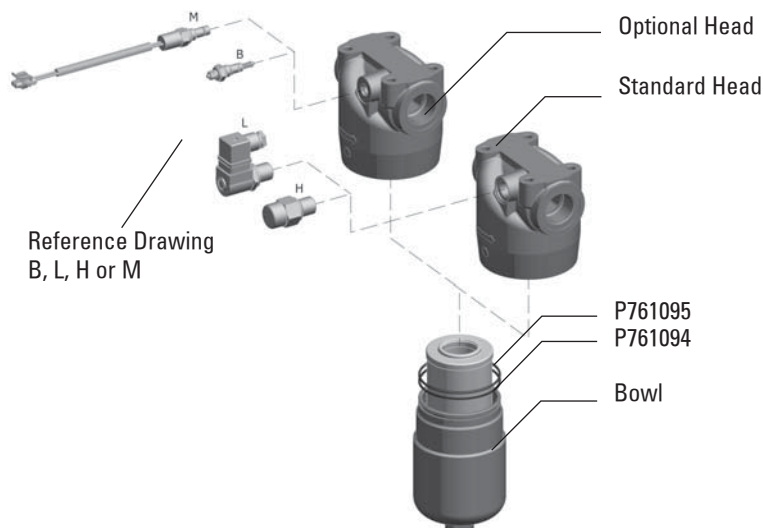

Performance Curves

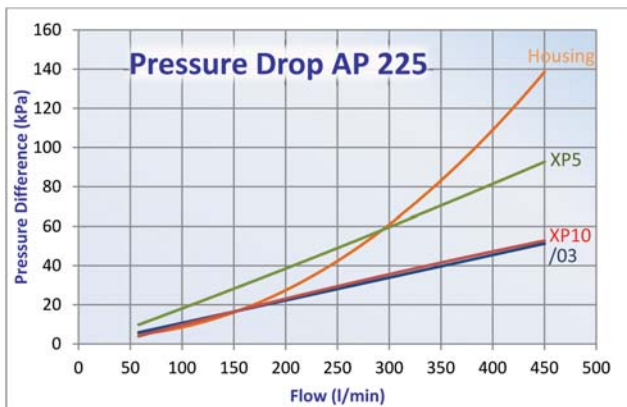
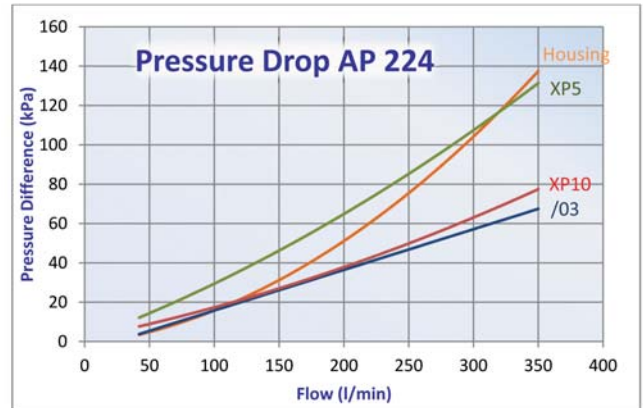
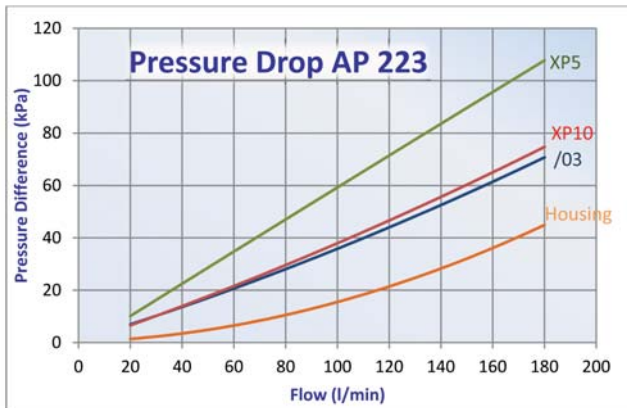
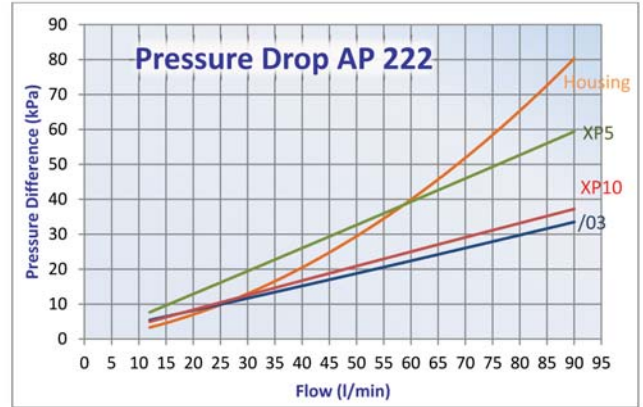
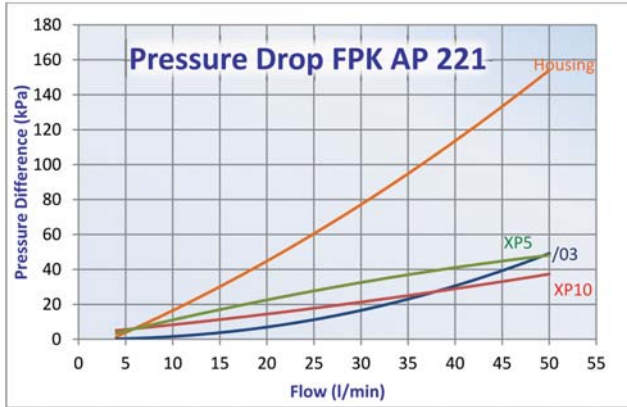



Donaldson.
FILTRATION SOLUTIONS

Donaldson Engine E-Catalogues

Check out Donaldson's Engine E-catalogue by clicking or browsing to one of the below links:

www.donaldson-catalogue.com/air

www.donaldson-catalogue.com/hydraulic

www.donaldson-catalogue.com/liquid

www.donaldson-catalogue.com/agriculture

www.donaldson-catalogue.com/truckBus

www.donaldson-catalogue.com/forklift

www.donaldson-catalogue.com/exhaust

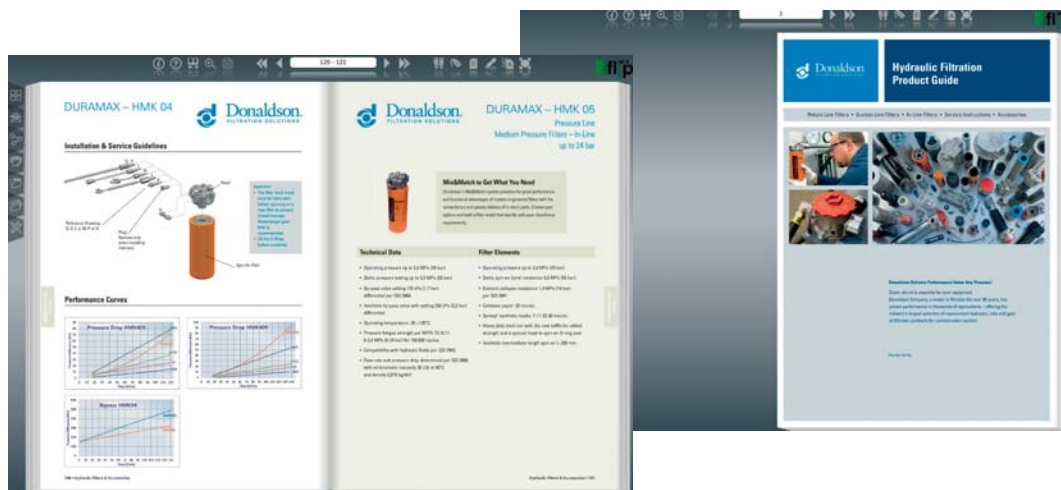

An E-Catalogue is an interactive format of a standard pdf with handy search functions. No password required!

REMARK: If the E-Catalogue doesn't open, it means that Adobe Flash Player is not installed on your computer.



Mix&Match to Get What You Need

Donaldson's Mix&Match system provides the great performance and functional advantages of custom-engineered filters with the convenience and speedy delivery of in-stock parts. Choose your options and build a filter model that exactly suits your cleanliness requirements.

Technical Data

- Operating pressure up to 42 MPa (420 bar).
- Static pressure testing up to 63 MPa (630 bar).
- Fatigue pressure of 2.000.000 cycles at 0-30 MPa (0-300 bar) per NFPA T 3.10.5.1, R2-2000.
- By-pass valve setting 600 kPa (6 bar) per ISO3968.
- Optional: Reverse flow valve which allows fluid to pass through the element in one direction but to by-pass the element when the flow is reversed.
- Operating temperature -20 +120°C.
- Compatibility with hydraulic fluids per ISO 2943.
- Flow rate and pressure drop per ISO3968 with oil kinematic viscosity 30 cSt at 40°C and density 0,875 kg/dm³.
- Filter head casting in spheroidal cast iron.
- Extruded steel bowl.
- Flange per SAE J518: 6000 PSI.

Filter Elements

- Synteq® synthetic media: 8-11-23 micron, reinforced with wire mesh.
- Collapse resistance 2 MPa (20 bar) per ISO 2941.
- Available collapse resistance 21MPa (210bar) – on customer request.



Components

		SYNTHETIC MEDIA						CARTRIDGE CODE
		/03		XP10		XP5		
		B _{23µlcl} ≥1000		B _{11µlcl} ≥1000		B _{8µlcl} ≥1000		
Family	Collapse	RMF		RMF		RMF		
AP361	Standard	50	P171733	50	P171732	40	P171731	AP451
	High		P176621		P176620		P176619	AP551
AP362	Standard	80	P171736	80	P171735	60	P171734	AP452
	High		P176624		P176623		P176622	AP552
AP363	Standard	120	P171739	120	P171738	80	P171737	AP453
	High		P176627		P176626		P176625	AP553
AP364	Standard	180	P171742	180	P171741	160	P171740	AP454
	High		P176630		P176629		P176628	AP554
AP365	Standard	300	P171745	300	P171744	270	P171743	AP455
	High		P176633		P176632		P176631	AP555
AP366	Standard	400	P171748	400	P171747	320	P171746	AP456
	High		P176636		P176635		P176634	AP556

RMF = Recommended Maximum Flow in liters/minute with use of standard housing.

BPV = Bypass Valve Setting

S = Additional Service Clearance

High Collapse elements are non-stock items, request your sales contact offer and lead-time

Alternative Housing Choices



Family	Alternative Housing (see anti-reverse flow valve or SAE Flange)	DIMENSIONS HOUSING																	POSSIBLE INDICATOR	
		A	B	C	D	E	F	G	H	J	L	M	N	T	V	W	S	BPV		Including valve to avoid reverse flow through element
			mm	mm	mm	mm	mm	mm	mm		mm	predilled holes	plugged		mm	mm	mm	bar		
AP361	P766433	G1/2	110	78,5	215	33	9	50	57	M10	Hex 30	G1/2	yes				130	6	yes	
AP362	P766434	G3/4	110	78,5	246	33	9	50	57	M10	Hex 30	G1/2	yes				165	6	yes	
AP363	P766435	G1	110	78,5	345	33	9	50	57	M10	Hex 30	G1/2	yes				270	6	yes	
AP364	P766436	G1 1/4	140	107	302	46	9	94	57	M12	Hex 30	G1/2	yes				180	6	yes	
AP365	P766437	G1 1/2	140	107	395	46	9	94	57	M12	Hex 30	G1/2	yes				280	6	yes	
AP366	P766438	G1 1/2	140	107	542	46	9	94	57	M12	Hex 30	G1/2	yes				420	6	yes	
AP362	P766439	Flange 3/4"	110	78,5	246	33	9	50	57	M10	Hex 30	G1/2	yes	M10	23,8	50,8	165	6	no	
AP363	P766440	Flange 1"	110	78,5	345	33	9	50	57	M10	Hex 30	G1/2	yes	M12	27,76	57,15	270	6	no	
AP363	P766444	Flange 1"	110	78,5	345	33	9	50	57	M10	Hex 30	G1/2	yes	M12	27,76	57,15	270	6	yes	
AP364	P766441	Flange 1" 1/4	140	107	302	46	9	94	57	M12	Hex 30	G1/2	yes	M14	31,75	66,68	180	6	no	
AP364	P766445	Flange 1" 1/4	140	107	302	46	9	94	57	M12	Hex 30	G1/2	yes	M14	31,75	66,68	180	6	yes	
AP365	P766442	Flange 1" 1/2	140	107	395	46	9	94	57	M12	Hex 30	G1/2	yes	M16	36,5	79,38	280	6	no	
AP366	P766443	Flange 1" 1/2	140	107	542	46	9	94	57	M12	Hex 30	G1/2	yes	M16	36,5	79,38	420	6	no	

P171945
P171947
P171944
P761056

Standard Housing	HOUSING DIMENSIONS														CARTRIDGE DIMENSIONS			POSSIBLE INDICATOR	
	A	B	C	D	E	F	G	H	J	L	M	N	S	BPV	Including valve to avoid reverse flow through element	X	Y		Z
	mm	mm	mm	mm	mm	mm	mm	mm	mm	mm	predrilled holes	plugged	mm	bar		mm	mm		mm
P766427	G1/2	110	78,5	215	33	9	50	57	M10	Hex 30	G1/2	yes	130	6	no	87	54	27	
P766428	G3/4	110	78,5	246	33	9	50	57	M10	Hex 30	G1/2	yes	165	6	no	122	54	27	
P766429	G1	110	78,5	345	33	9	50	57	M10	Hex 30	G1/2	yes	270	6	no	230	54	27	
P766430	G1 1/4	140	107	302	46	9	94	57	M12	Hex 30	G1/2	yes	180	6	no	140	78	40	
P766431	G1 1/2	140	107	395	46	9	94	57	M12	Hex 30	G1/2	yes	280	6	no	240	78	40	
P766432	G1 1/2	140	107	542	46	9	94	57	M12	Hex 30	G1/2	yes	420	6	no	380	78	40	

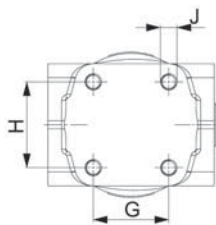
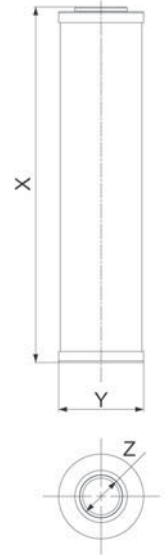
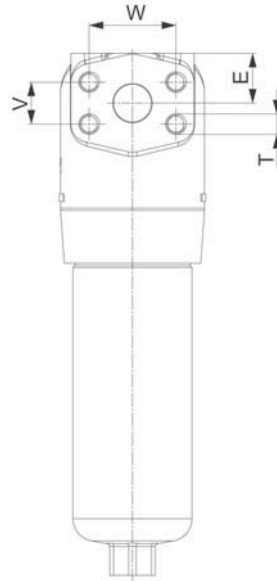
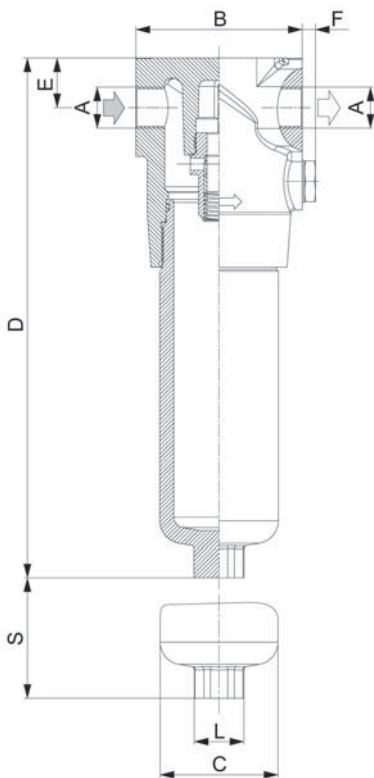

**HIGH PRESSURE
FILTERS**

Indicator Choices

Part	Kind		Reference Drawing	Setting (bar)	Contact	Pro-tection Class	Cable Clamp	Max. Values	Remark
P171945	Visual	Differential	H	5					
P171947	Electrical + Visual	Differential	K	5	Normally Open/ Closed	IP65	PG11	250V AC; 30 VDC; 5A res. and ind.	
P171944	Electrical + Visual	Differential	K	5	Normally Open/ Closed	IP65	PG11	250V AC; 30 VDC; 5A res. and ind.	with thermostat at min. temperature at 30°C
P761056	Electrical	Differential	L	5	Normally Open/ Closed	IP65	PG11	30 V DC; 30 V AC; 0,5 A res. and 0,2 A ind.	

Installation & Service Guidelines

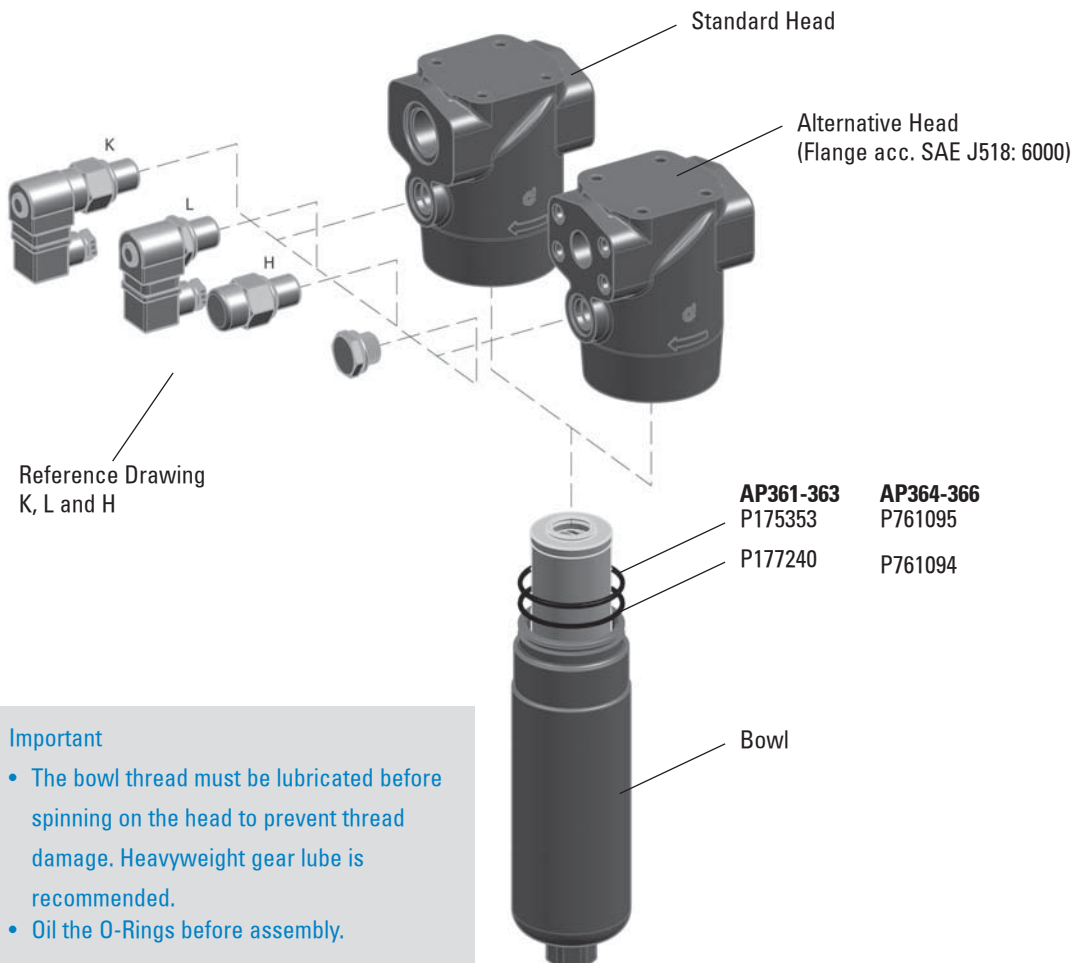

Important

- The bowl thread must be lubricated before spinning on the head to prevent thread damage. Heavyweight gear lube is recommended.
- Oil the O-Rings before assembly.

Performance Curves

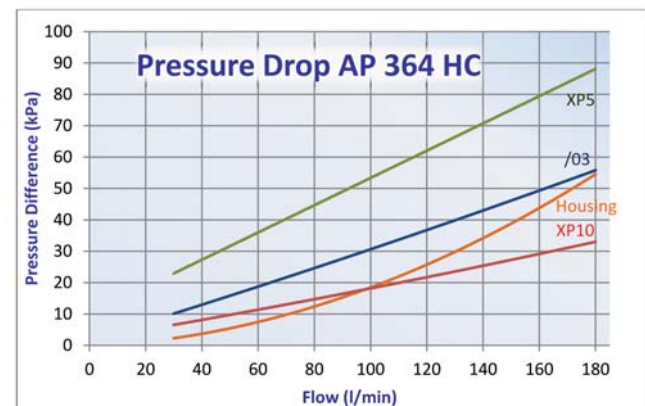
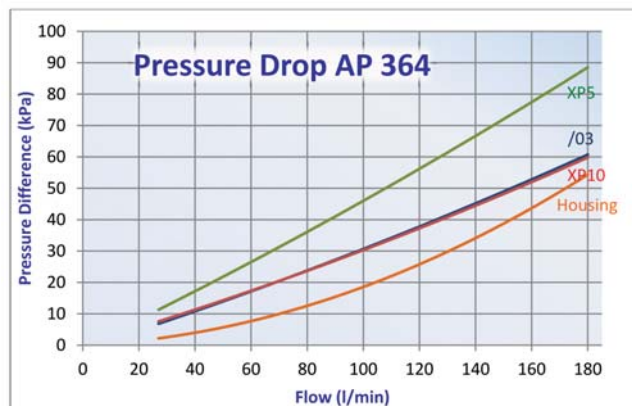
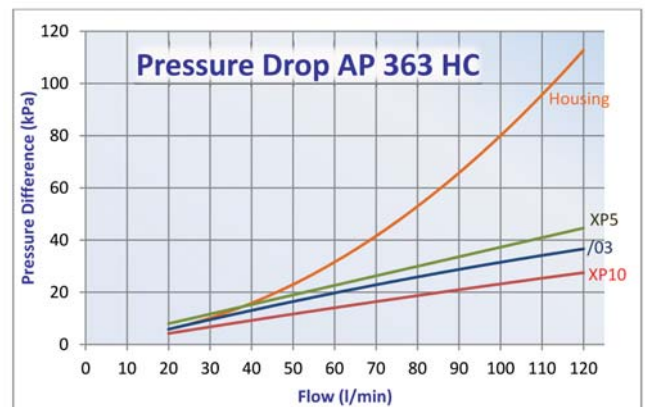
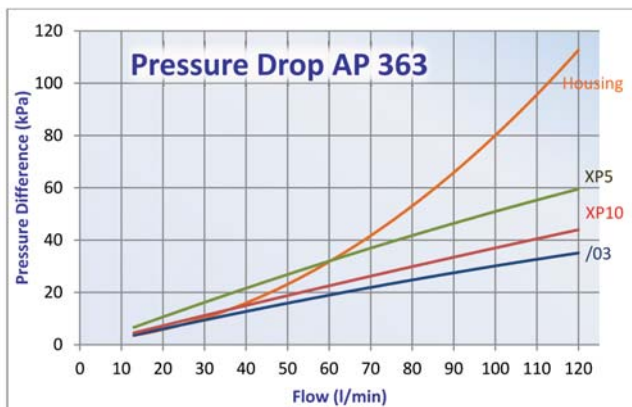
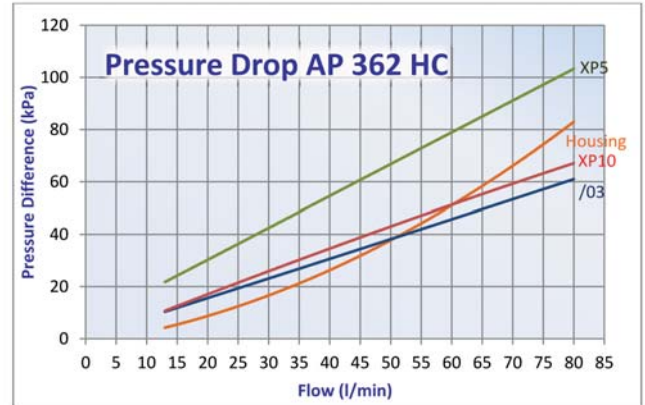
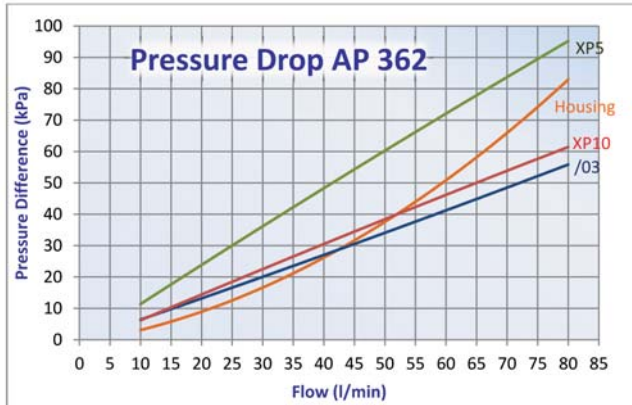
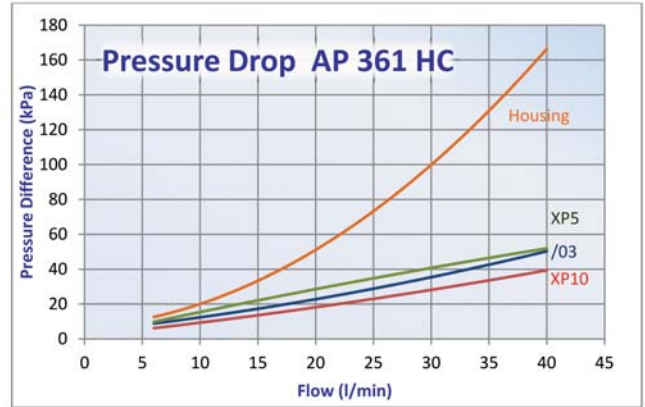
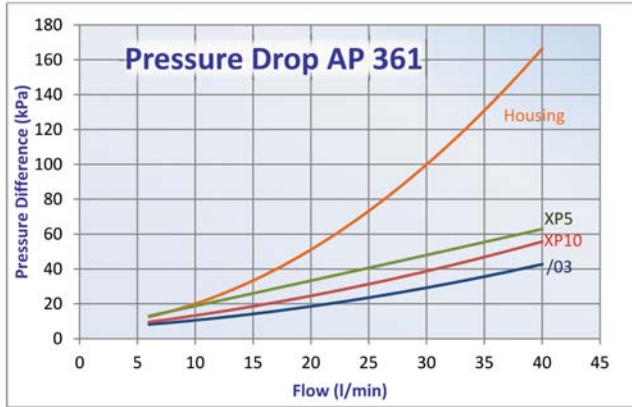

HIGH PRESSURE
FILTERS

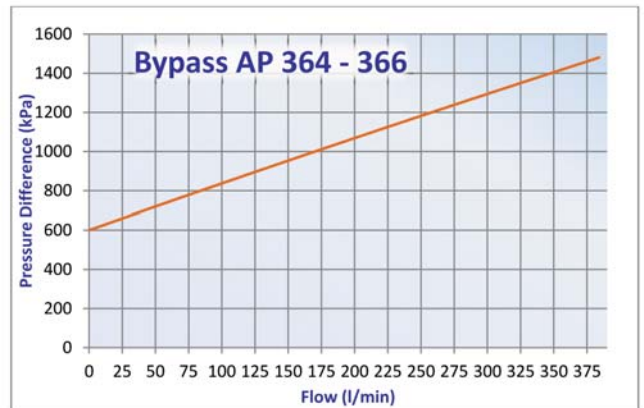
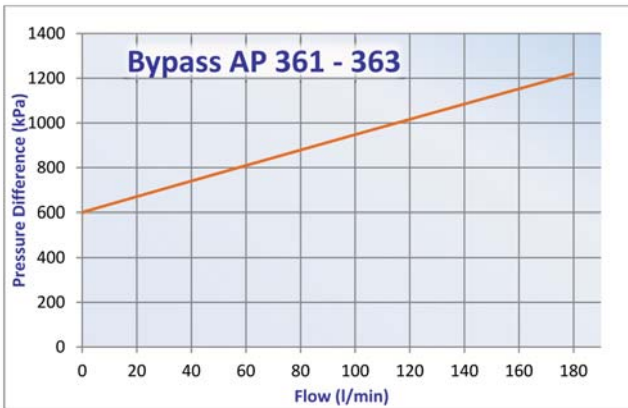
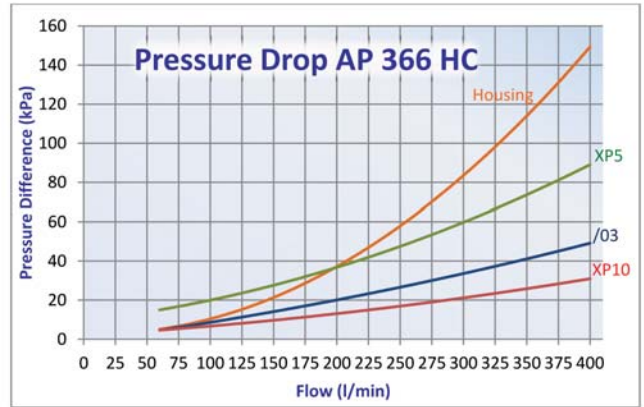
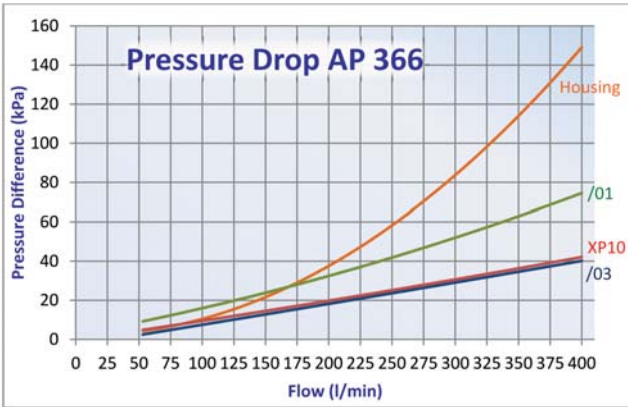
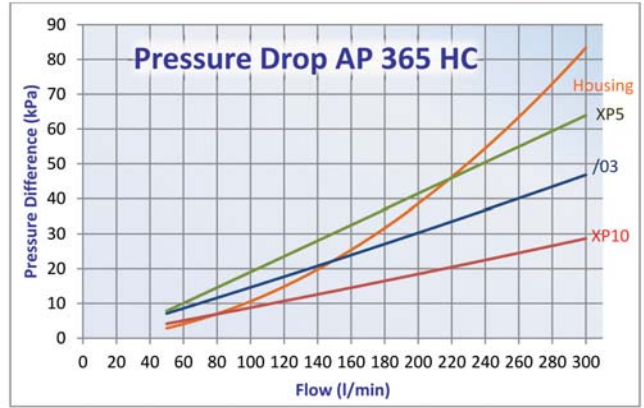
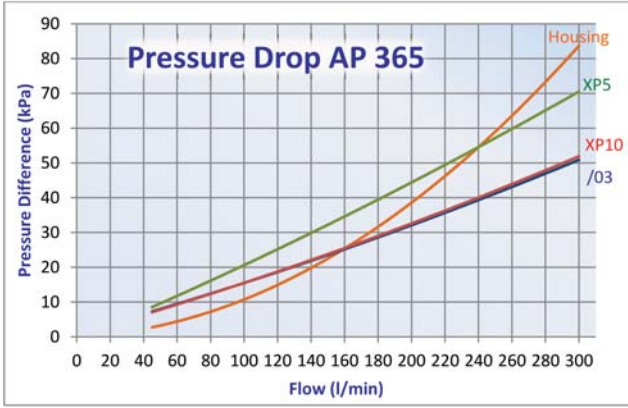

HIGH PRESSURE FILTERS



Technical Data

- Operating pressure up to 42 MPa (420 bar)
- Static pressure testing up to 63 MPa (630 bar).
- Fatigue pressure of 2.000.000 cycles at 0-30 MPa (0-300 bar) per NFPA T 3.10.5.1, R2-2000.
- Operating temperature -20 +120°C.
- Compatibility with hydraulic fluids per ISO 2943.
- Flow rate and pressure drop per ISO 3968 with oil kinematic viscosity 30 cSt at 40°C and density 0,875 kg/dm³.
- Steel head.
- Steel bowl.

Filter Elements

- Wire mesh: 60 micron.
- Synteq[®] synthetic media: 8-11-23 micron, reinforced with wire mesh.
- Collapse resistance 20 MPa (200 bar) per ISO 2941.

Components



Family	WIRE MESH MEDIA		SYNTHETIC MEDIA						CARTRIDGE CODE
	/6		/03		/02		/01		
	60µm		$\beta_{25\mu m(c)} \geq 1000$		$\beta_{11\mu m(c)} \geq 1000$		$\beta_{8\mu m(c)} \geq 1000$		
	RMF	Sparepart	RMF	Sparepart	RMF	Sparepart	RMF	Sparepart	
LC2	2	P171771	2	P171769	2	P171768	2	P171767	CLC2
LC5	5	P171776	5	P171774	5	P171773	5	P171772	CLC5
LC10	10	P171781	10	P171779	10	P171778	10	P171777	CLC10
LC20	20	P763493	20	P763485	20	P763489	20	P763487	CLC140

RMF = Recommended Maximum Flow in liters/minute with use of standard housing.

Stocked item (check e-commerce for availability)

Non highlighted numbers: non-stocked items, request your sales contact for offer and lead-time.

Performance Curves

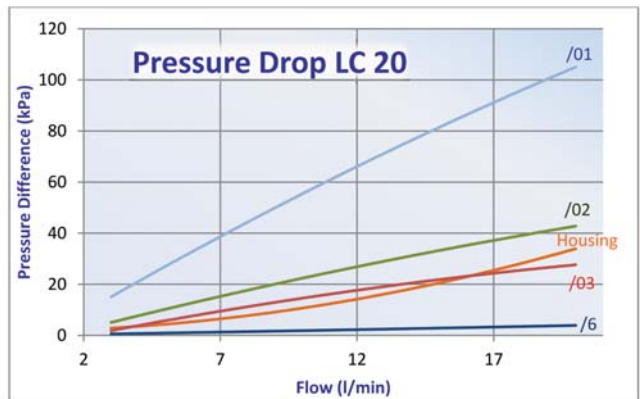
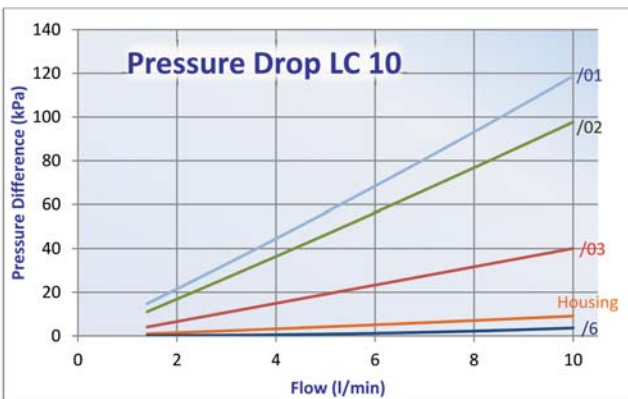
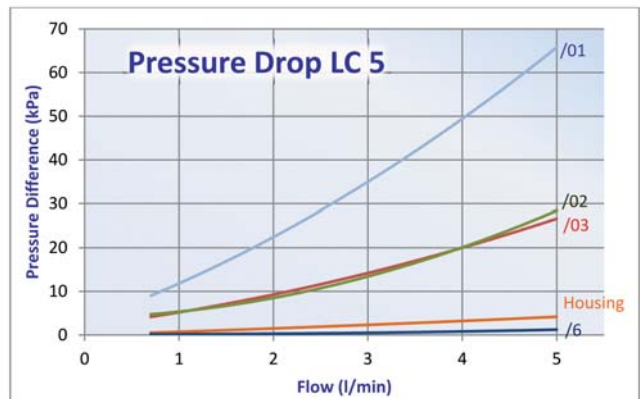
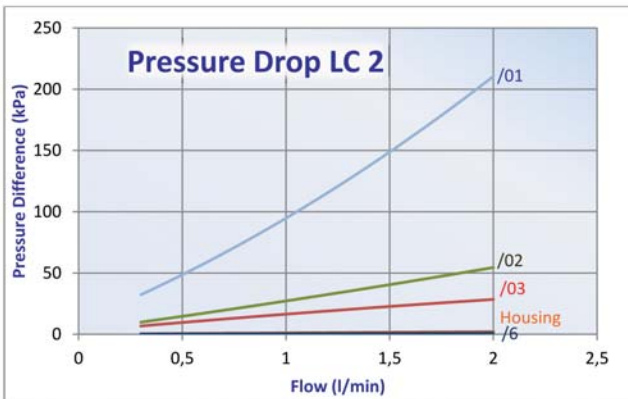

HIGH PRESSURE FILTERS

Standard Housing without cartridge	HOUSING DIMENSIONS					CARTRIDGE DIMENSIONS		
	A	B	C	Hex 1	Hex 2	X	Y	Z
		mm	mm	mm	mm	mm	mm	mm
P767138	G3/8	42	103	Hex 27	Hex 36	47	21	9,5
P767139	G1/2	58	135	Hex 30	Hex 50	70	28,6	15,8
P767140	G1/2	58	182	Hex 30	Hex 50	117	28,6	15,8
P767141	G1/2	70	181	Hex 33	Hex 33	90	43	22,2

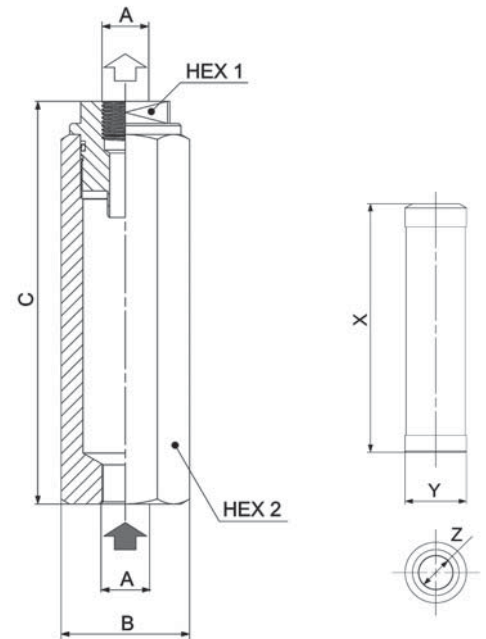

Installation & Service Guidelines



Important

- The bowl thread must be lubricated before spinning on the head to prevent thread damage. Heavyweight gear lube is recommended.
- Oil the O-Rings before assembly.

FPK02&04-AP220

FPK02-AP280

FPK03&04-AP420

FMK-FM

FCK-LC



Open empty housing
in correct order



Remove carton ring
before use



Check if O-ring between
lid and housing is installed and intact



Check if O-Ring on cartridge is installed and
intact

For FK:
Mount O-ring over stud



For Low Pressure cartridges:
Mount spring on cartridge



Mount element in
housing



For Combo 120:
Align arrows as shown



Assemble lid on housing



Assemble bolts and
screws in correct order



Tighten screws, bolts or lid until thread ends
For spin-ons: hand tighten until contact
between O-ring and head is made; and then
continue by hand as indicated on spin-on



Degrease surface where sparepart sticker
will be mounted
Only for cartridge type filters



Sparepart sticker in each sparepart box



Fix sparepart sticker in area indicated –
Ready!



Do not forget seals





- T.R.A.P.™ breathers..... 150
- Hydraulic Cart for Off-Line Filtration 151
- TCO 154
- TCA..... 156
- FS..... 157
- FFCA 158
- LVO/LVOT 159



Products

Characteristics	10µm Cellulose Media						DIMENSIONS				
	non-pressurized		Anti-Rollover valve (leakage reduction)		pressurized 0.4 bar		A	B	C	D	E
	Blue		Natural		Red		mm	mm	mm	mm	mm
RMF	Family		Family		Family						
300	FS7	P767027	FS7	P767025	FSP7	P767023	G1/2	72,5	48	14,5	Hex 27
300	FS8	P767029	FS8	P766645	FSP8	P767019	G3/4	72,5	48	14,5	Hex 27
300	FS9	P767031	FS9	P766646	FSP9	P767021	G1	72,5	48	14,5	Hex 27

RMF = Recommended Maximum AIR-Flow in liters/minute

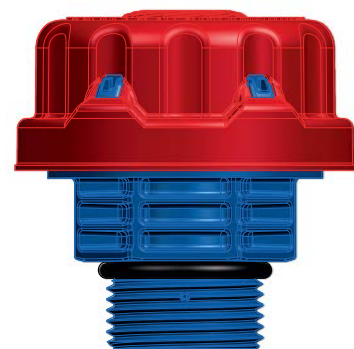
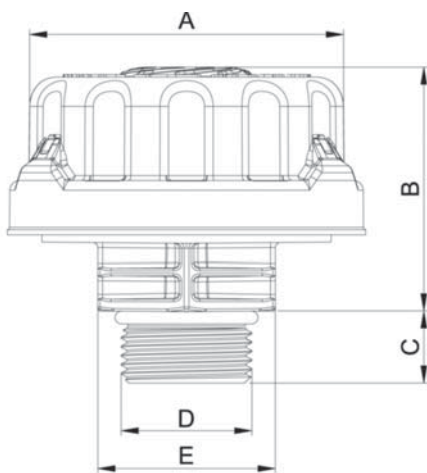

Cap color depending on characteristics



Differential pressure indicators

- Lets you know when to change elements

Two pressure filters mounted in series

- Allows for particulate/water removal or coarse/fine particle removal

Removable angled drip tray

- Easy clean up, fluid will not leak out when tipped back

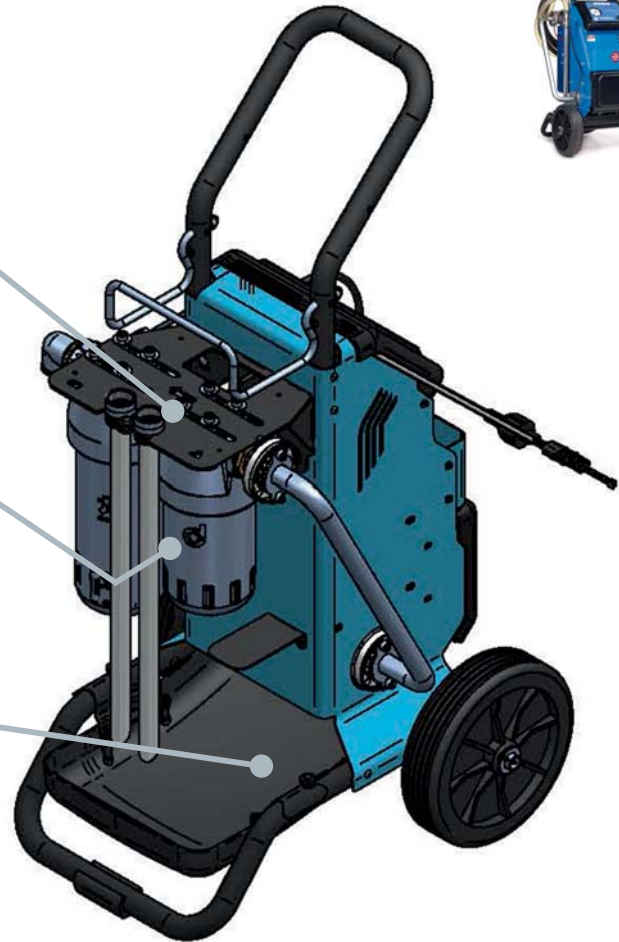

Dual electrical indicators with flashing on the dashboard + manometer for pump

- (to monitor filter performance and give servicing instructions)

Motor mounted inside

- Better balance
- Fluid will not drip on motor when changing filters
- Main pump protected by a cover

Overload protected switch

- Protects motor and pump from overheating

Integrated safety relief valve

- Protects against over pressurizing

Optional

- Anti-drain suction valve

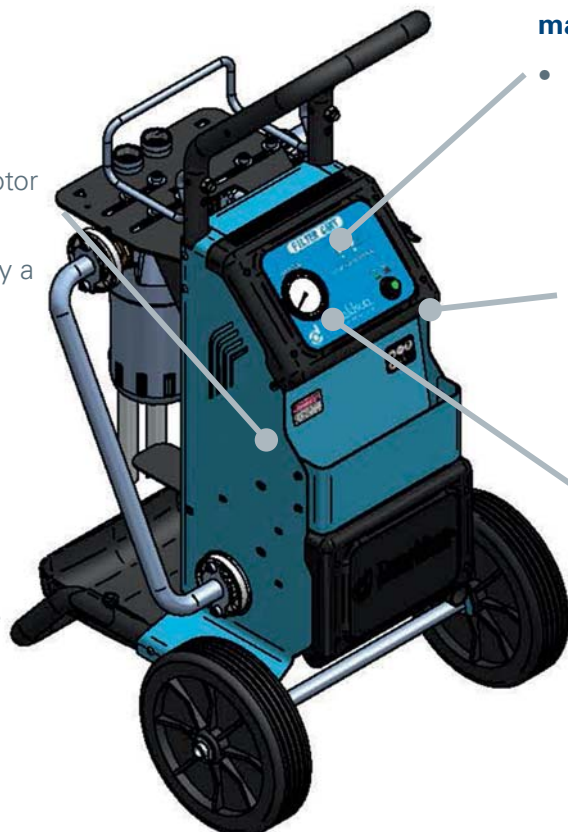

Hydraulic Cart for Off-Line Filtration



Oil filter cart features

Features	Benefits
Rugged and durable frame	Enables long service life
High-efficiency media grades	Cost effective filtration
Two pressure filters	Two-stage filtration – Fine Particulate and/or Water
Safety relief valve	Prevents over pressurizing and damage to pump, hoses and filters
Overload protected switch	Prevents motor/pump from overheating

Applications	
Filter new fluid	New fluids are usually above the recommended ISO cleanliness level
Off-line filtration	Filter cart can be used to supplement existing filtration
Transferring fluid	Fluid is transferred from a storage container (tote, drum, tank, etc.) to a machine's reservoir
Water removal	Using Donaldson water removal elements can help remove free water from the system
Flushing after repairs and rebuilds	After machines are serviced or repaired they need to be flushed thoroughly before they are returned to service
Flushing during equipment commissioning	New machines have original fabrication debris and dirt that has ingressed during transport and storage

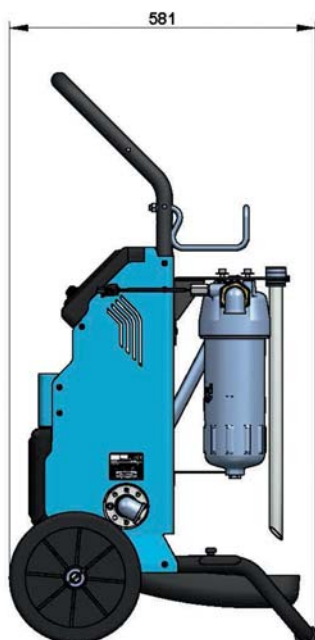

ACCESSORIES



Oil filter cart specifications

Hydraulic Cart	X770793
Supply	220 V @ 50/60 Hz
Electric motor	Built-in thermal lockout
Maximum fluid viscosity	300 cSt
Flow rate	50 lpm
Maximum Pressure	5 bar (internal bypass)
Indicators	Dual electrical indicators with flashing on the dashboard + manometer for pump pressure
Suction hose	4 m
Discharge hose	4 m
Dirt filtration	P766847 ($\beta_{7\mu m(c)} > 1000$) *
Water adsorption	P766849 (95% Water removal efficiency) *
Optional	Suction anti-drain valve

* Different filter configurations are possible.



Products

		Without Pressure Relief Valve			With Pressure Relief Valve			
		CELLULOSE MEDIA			CELLULOSE MEDIA			
		/4	/1		/4	/1		
		40µm Air	10µm Air		40µm Air	10µm Air		
Family	RMF		RMF		RMF		RMF	
TCO300	300	P171847	270	P171848				
TCO500	500	P173251	470	P171855	500	P171850	470	P171857
TCO501	500	P171851	470	P171856	500	P171852	470	P171858
TCO502	500	P171853	470	P171859	500	P171854	470	P171860
TCO502			470	P761184				

RMF = Recommended Maximum Flow in liters/minute

Technical Data

Series TCO 300:

- Non removable 500 micron mesh basket.

Series TCO 500:

- Removable 500 micron mesh basket.
- 40-10 micron air filter.
- Easy tightening.
- Drilled flanges and fixing screws.

Series TCO 501:

- Features as TCO 500 but with weldable flange.

Series TCO 502:

- Features as TCO 500 but with longer weldable external tube.

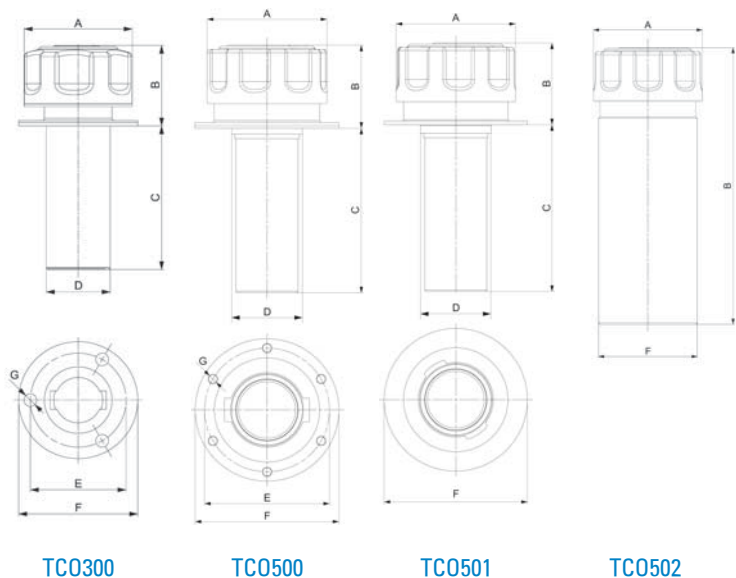

Series TCO 503:

- Non removable 125 micron mesh basket.

Series TCO 500, 501, 502 and TCO 503:

- Available with pressure relief valve setting at 40 kPa (0,4 bar).

For all tank mounting hole: D+2 mm; all screws: M5x12 (UNI 5931)

DIMENSIONS						
A	B	C	D	E	F	G
mm	mm	mm	mm	mm	mm	mm
46	35	63	28	41	51	5,5 (3)
70	46	100	40	73	84	5,5 (6)
70	46	100	40		84	
70	180				64	
70	89	188	59	73	84	5,5 (6)

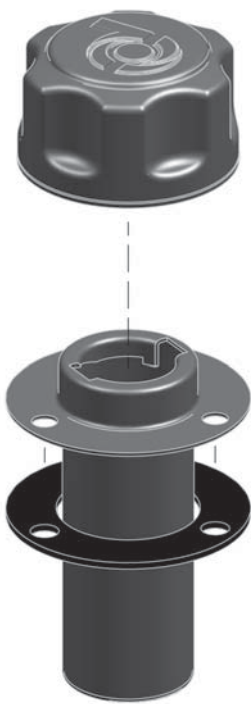

TCO300



TCO500

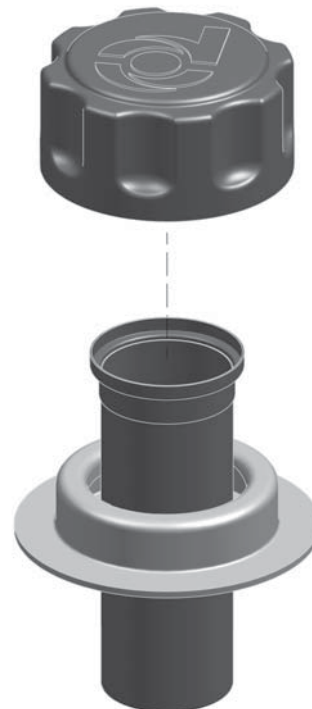

TCO501



TCO502

ACCESSORIES



Products

	Partnumber	Reference Drawing	Relief Valve	Lock Connection	Extra Features
RMF			bar		
270	P763513	A	none	no	chain
270	P763528	B	none	no	G1/4 screw masculin
500	P762065	A	0,4	yes	-
500	P173266	A	0,4	yes	oil antisplash
500	P173259	A	none	yes	removable mesh filter 500µm
500	P761036	A	none	yes	removable mesh filter 500µm
500	P173253	A	0,4	yes	removable mesh filter 500µm
470	P172493	B	0,4	yes	G3/4 screw masculin
500	P173475	C	0,7	yes	M80x2 feminin
-	P763672	C	none	yes	M80x2 feminin

DIMENSIONS							Holes
A	B	C	D	E	F	G	Amount
mm	mm	mm	mm	mm	mm	mm	
46	35	63	28	41	51	5,5	3
46	41	14	-	-	-	-	-
70	46	-	-	73	84	5,5	
70	46	22	38	73	84	5,5	6
70	46	100	38	73	84	5,5	6
70	46	100	38	73	84	5,5	6
70	46	138	38	73	84	5,5	6
70	49	20	-	-	-	-	-
100	74	-	-	-	-	-	-
100	74	-	-	-	-	-	-

RMF = Recommended Maximum AIR-Flow in liters/minute

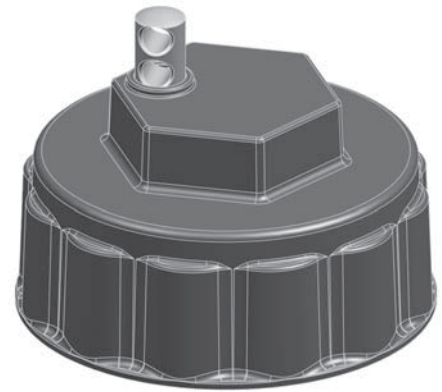
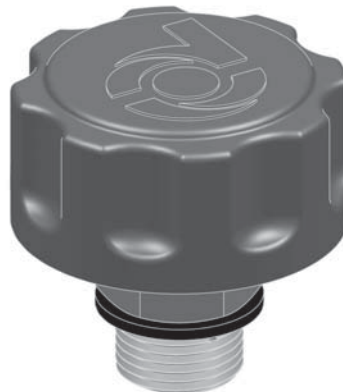
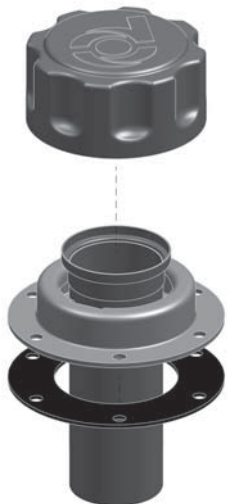
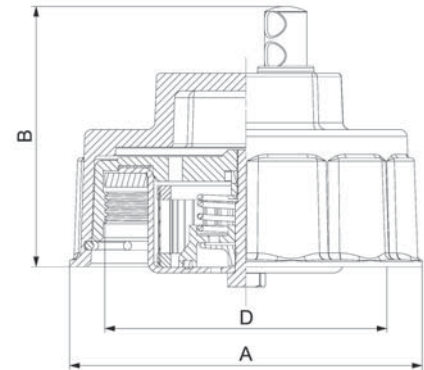
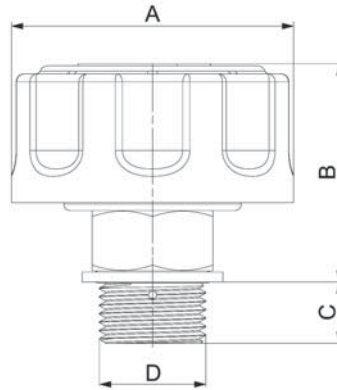
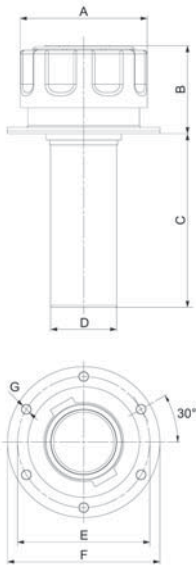

Reference Drawing A

Reference Drawing B

Reference Drawing C



Products

Family	RMF	/6		/4		/1			CARTRIDGE CODE	DIMENSIONS				
		WIRE MESH				CELLULOSE MEDIA				A	B	C	D	Reference Drawing
		Assembly	Element	Assembly	Element	RMF	Assembly	Element		mm	mm	mm		
FS1	200			P172381	P172433	200	P761046	P172435	CS1	52	45	9	M12x1.5	A
FS3	200			P172382	P172433	200	P761047	P172435	CS1	52	45	9	M18x1.5	A
FS4	200			P172383	P172433	200	P761048	P172435	CS1	52	48	10	M22x1.5	A
FS5	200			P172384	P172433	200	P761049	P172435	CS1	52	45	9	G 1/4	A
FS6	200			P172385	P172433	200	P761050	P172435	CS1	52	46	9	G 3/8	A
FS7	500			P172386	P171783	500	P761051	P175447	CS2	72	62	10	G 1/2	A
FS8	1000			P172387	P171784	1000	P761052	P761045	CS3	108	77	15	G1	A
FS9	1500	P172389	P171786	P172388	P171785	1500	P761053	P761054	CS4	132	100	48		B

RMF = Recommended Maximum AIR-Flow in liters/minute

Technical Data

- To filter air entering the reservoir.
- Ports treaded per ISO 228/1 and UNI 4535-UNI 5545.
- Filter Elements in wire mesh 60-40 micron and cellulose media 10 micron.

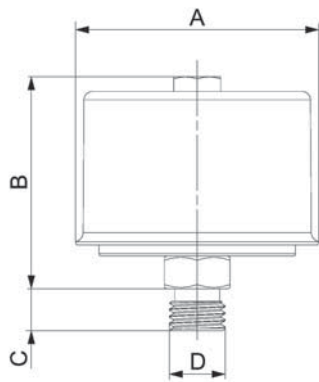

Reference Drawing A

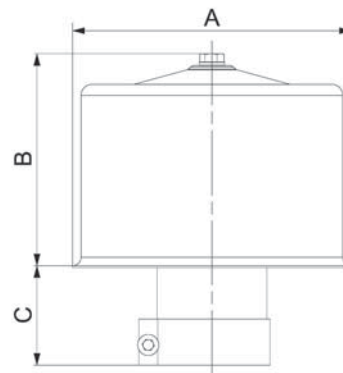

Reference Drawing B

FFCA

Tank Breathers Spin-On with Flange and Fixing Screws



Products

Family	RMF	Wire Mesh		Cellulose Media	Synthetic Media	Flange used to create complete assy	CARTRIDGE CODE	FILTER DIMENSIONS								
		/6	/3	/1	/02			A	B	C	D	E	F	G	H	L
		60µm Air	30µm Air	10µm Air	10µm Air			mm	mm	mm	mm	mm	mm	mm	mm	mm
FFCA60	1200	P171607	P171606	P550268	P171602	P177227	CA60	96	149	50	199	18	50	5,5	41	3
FFCA80	1600	P171612	P171611	P171610	P171608		CA80	96	207	50	257	18	50	5,5	41	3
FFCA160	2400	P171617	P171616	P550148	P171613	P760682	CA160	126	181	50	231	32	84	5,5	73	6
FFCA200	3000	P171622	P171621	P171620	P171618		CA200	126	226	50	276	32	84	5,5	73	6

RMF = Recommended Maximum AIR-Flow in liters/minute

Technical Data

- To vent the reservoir compensating oil volume changes, filtering air in suction.
- Wire Mesh Media with filtration efficiency 60 and 30 micron.
- Cellulose media with filtration efficiency 10 micron.
- Synthetic Media with filtration efficiency 10 micron.

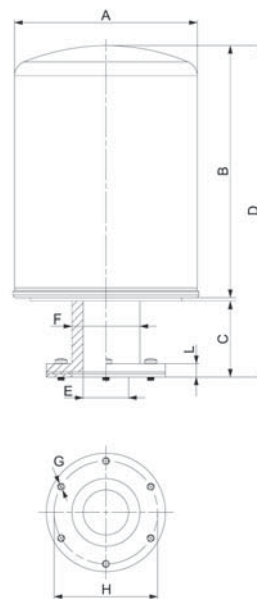
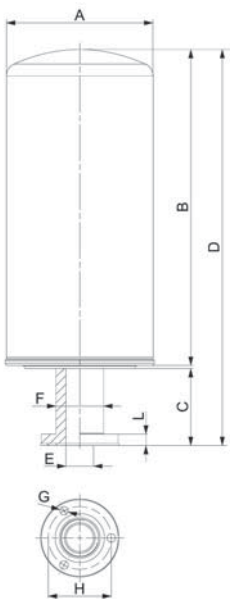

ACCESSORIES



Products

Family	Without thermometer	With thermometer	LEVEL GAUGE DIMENSIONS						Reference Drawing		
			A	B	C	D	E	F		G	H
			mm	mm	mm	mm	mm		mm	mm	
LVO(T)76	P171913	P171915	108	37	23	41	76	M10	31	39	A
LVO(T) 77	P171914	P171916	108	37	23	41	76	M12	31	39	A
LVO(T) 127	P171917	P171919	159	37	23	41	127	M10	82	39	A
LVO(T) 128	P171918	P171920	159	37	23	41	127	M12	82	39	A
LVO(T) 150	P177439	P177438	172	22	28	37	150	M10	172	NA	B
LVO(T) 254	P171921	P171922	285	37	23	41	254	M12	2x82	39	A

Technical Data

- Installed on tanks holding mineral oils or petroleum based fluids, they allow a clear and direct oil level or oil level and temperature indication.
- Lens of transparent material protected by metal section, seals "O" Ring of "BUNA" rubber.
- Maximum working pressure: 100 kPa (1bar) for pressurised tanks.
- Recommended bolt tightening torque 10 Nm, with inside nut for tightening directly on the tank.
- LVO serie without thermometer.
- LVOT with thermometer 30°-90°C.
- Threaded per UNI 4534-UNI 5545

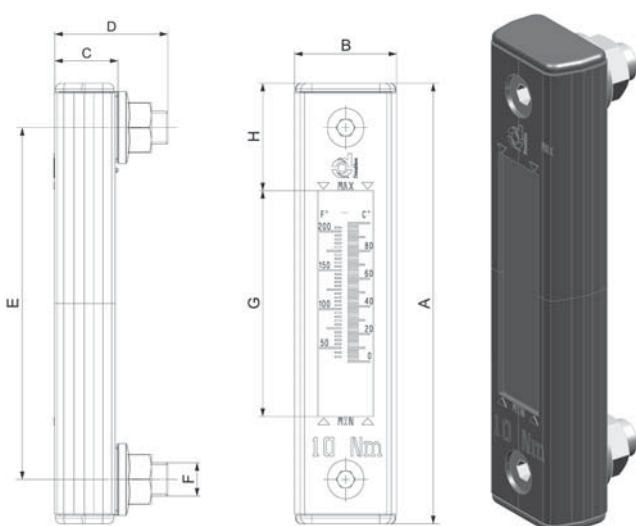

Reference Drawing A

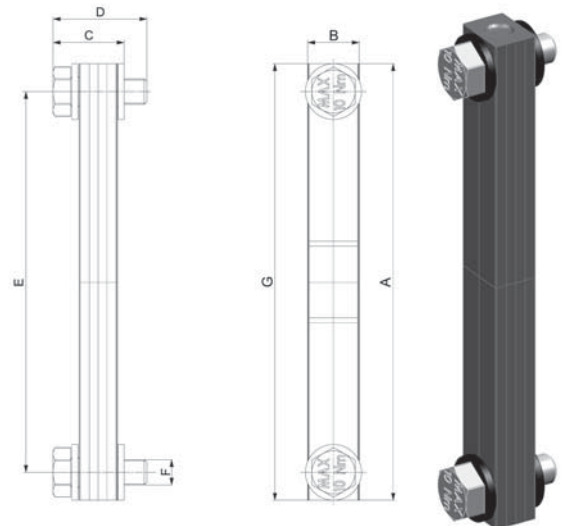

Reference Drawing B



Donaldson.
FILTRATION SOLUTIONS

Donaldson Engine E-Catalogues

Check out Donaldson's Engine E-catalogue by clicking or browsing to one of the below links:

www.donaldson-catalogue.com/air

www.donaldson-catalogue.com/hydraulic

www.donaldson-catalogue.com/liquid

www.donaldson-catalogue.com/agriculture

www.donaldson-catalogue.com/truckBus

www.donaldson-catalogue.com/forklift

www.donaldson-catalogue.com/exhaust

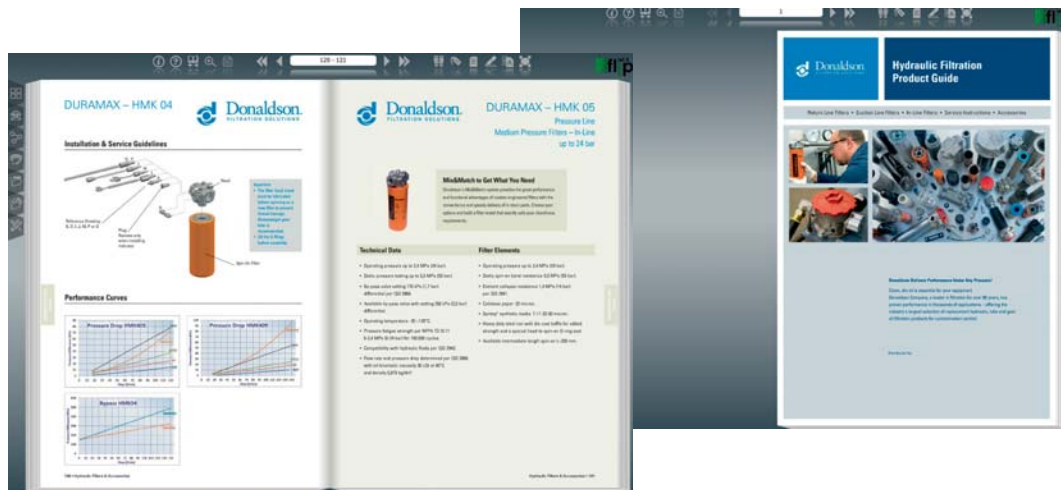

An E-Catalogue is an interactive format of a standard pdf with handy search functions. No password required!

REMARK: If the E-Catalogue doesn't open, it means that Adobe Flash Player is not installed on your computer.



	FIK-FIO(T) FHK-FIR SRK-Combo 200 + 300	FLK-FLS FLK-FLA	FPK02&04-AP220 FPK02-AP280 FPK03&04-AP420 FMK-FM FCK-LC	FIK-FIS SRK-Combo 120	FBK-FRCA FBK-FACA HMK04 HMK05
Open empty housing in correct order					
Remove carton ring before use					
Check if O-ring between lid and housing is installed and intact					
Check if O-ring on cartridge is installed and intact					
For FIK: Mount O-ring over stud					
For Low Pressure cartridges: Mount spring on cartridge					
Mount element in housing					
For Combo 120: Align arrows as shown					
Assemble lid on housing					
Assemble bolts and screws in correct order					
Tighten screws, bolts or lid until thread ends For spin-ons: hand tighten until contact between O-ring and head is made; and then continue by hand as indicated on spin-on					
Degrease surface where sparepart sticker will be mounted Only for cartridge type filters					
Sparepart sticker in each sparepart box					
Fix sparepart sticker in area indicated - Ready!					
Do not forget seals					

SERVICE INSTRUCTIONS



Filter
FIK-FDK
FKH

Filter FIK



3. Remove the cover.

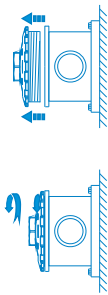
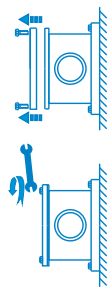

4. Remove the filter element as gently as possible avoiding contaminant drops in the clean side of the housing. Discard the cartridge, the seal and the spring.



5. Clean out any sediment from the inside of the housing/bowl.

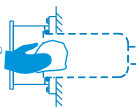

6. Clean out any sediment from the cover side and lubricate the seal.



7. Lubricate element o-ring with clean system oil and install the element. Reassemble the cover until the threads end.

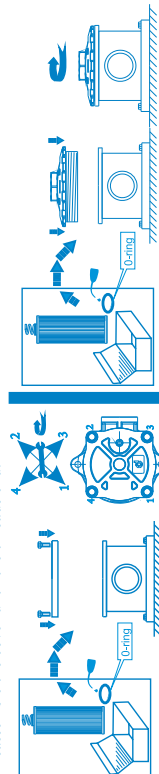

8. Bleed the hydraulic system and check for leaks.

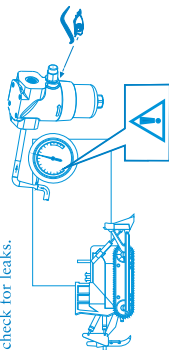

NEVER attempt to clean a used cellulose or synthetic filter element. The filter media will be damaged.

ONLY use genuine replacement parts. NEVER substitute an incorrect part even if it is of the same size.

NEVER fit a damaged replacement filter element (e.g. Dented canister, warped end caps, ripped media).

Once the spin-on or cartridge has been replaced, if there are the conditions (filter installed vertically with head pointing upwards), we recommend to fill the filter with clean oil before pressurizing the system.

NEVER run the system without a filter element - there would be no system protection.

ALWAYS dispose of used filter elements and old oil in accordance with local regulations.

ALWAYS wear protective equipment such as safety glasses and gloves during filter replacement.

This equipment has been assessed in accordance with the guidelines laid down in the European Pressure Directive 97/23/C.

We hereby declare the equipment meets the requirements of article 3, section 3, thus meeting the directive requirements. Under the provisions of this directive the filter assembly is suitable for use with group 2 fluids only.



Manufactured by:
Donaldson Italia S.r.l.
Via dell'Industria 17
I 46035 Ostiglia (MN)
Italy
T telephone +39 0386 30211
Fax. +39 0386 800405
OstigliaRD@emea.donaldson.com

European Headquarters:
Donaldson Europe DEBVA
Interfeuvellaan 1
B-3001 Leuven
Belgium
T telephone +32 16 383811
Fax. +32 16 400077
Engine-europe@emea.donaldson.com











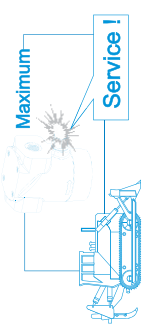

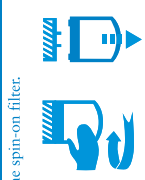
For further information contact your local Donaldson dealer
www.Donaldson.com

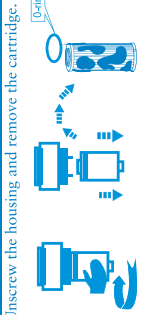
E507943 rev.3

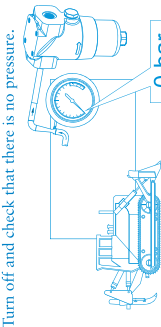
Hydraulic Filters Service Instructions

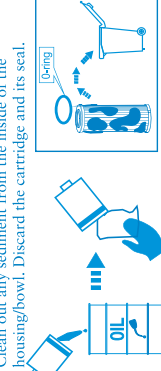
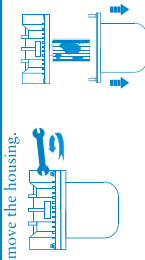
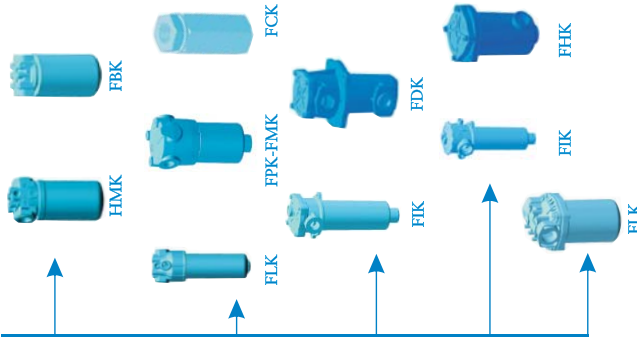
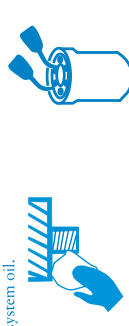
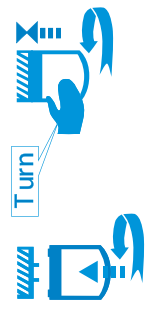
Only to be used by professionals

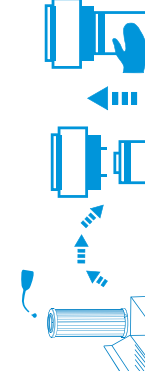

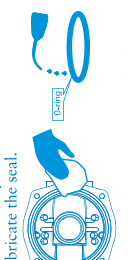
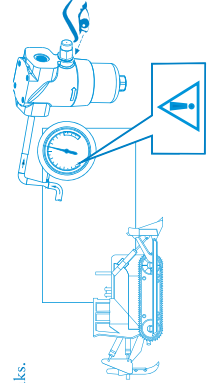
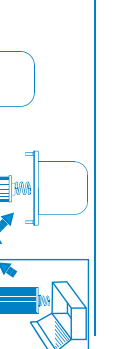
<p>Filter Replacement Instructions</p> <p>1. The filter requires servicing when the indicator shows the element to be clogged or in accordance with the service interval instructions of the OEM.</p>  <p>Maximum Service!</p>	<p>Filter HMK-FBK</p>  <p>3. Remove the spin-on filter.</p> 	<p>Filter FPK-FMK FLK-FCK</p>  <p>3. Unscrew the housing and remove the cartridge.</p> 	<p>Filter FLK</p> 
<p>2. Turn off and check that there is no pressure.</p>  <p>0 bar</p>	<p>4. Discard both the spin-on and its seal.</p> 	<p>4. Clean out any sediment from the inside of the housing/bowl. Discard the cartridge and its seal.</p> 	<p>3. Remove the housing.</p> 
<p>3. Remove filter :</p> 	<p>5. Clean the surfaces of the filter head. Lubricate thread and spin-on seal with clean system oil.</p>  <p>6. Screw the spin-on filter till upper surface and turn spin-on as shown on filter.</p>  <p>Turn</p>	<p>5. Check the seal integrity, lubricate the seal and the threads with clean system oil.</p>  <p>6. Lubricate element o-ring with clean system oil and install element. Reassembly the housing until threads end.</p> 	<p>5. Clean out any sediment from the inside of the housing/bowl.</p>  <p>6. Clean out any sediment from the head side and lubricate the seal.</p> 
	<p>7. Bleed the hydraulic system and check for leaks.</p> 		<p>7. Lubricate element o-ring with clean system oil and install element. Reassemble the housing.</p> 

Application Guide for Donaldson Filter Media

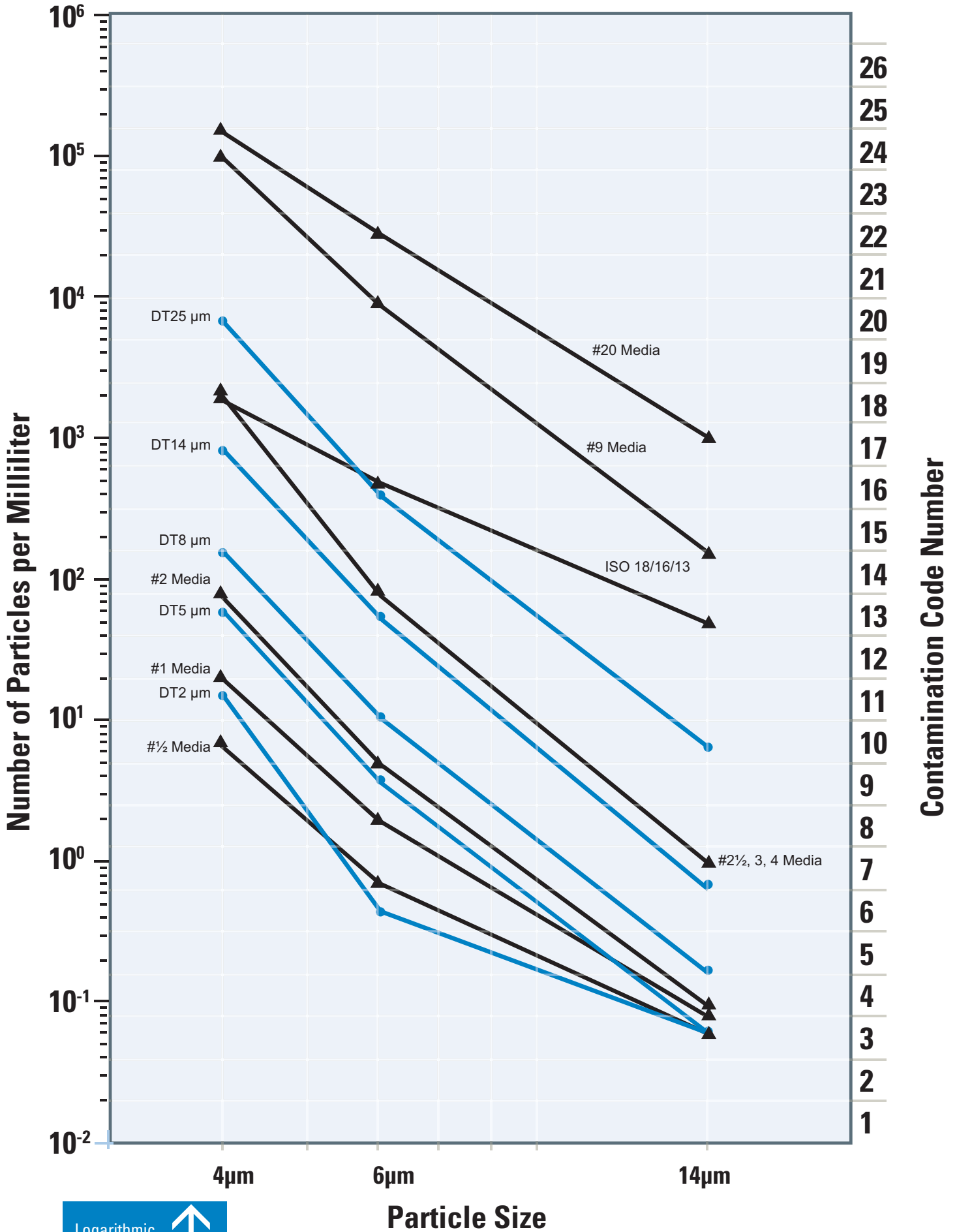

Logarithmic Scale
 ↑
 This represents the number of particles at a given size in the oil sample



- FIK-FIO 166
- FIK-FIOT 169
- FIK-FIO/FIOT..... 171
- FIK-FIS 173
- FLK-FLS..... 174
- FBK-FRCA..... 176
- FHK-FIR..... 177
- FLK-FLA..... 178
- FBK-FACA..... 180
- FMK-FM..... 181
- HMK04 182
- HMK05 183
- FPK02 184
- FPK02-04..... 185
- FPK03-04..... 186
- FCK-LC 187

Return Line Filters

Low Pressure Filters In-Tank FIK-FIO



		WIRED MESH			CELLULOSE MEDIA			SYNTHETIC MEDIA		
Family	Version Assembly	Version	/09	/6	/3	/1	/03	/02		
			90µm	60µm	β _{0.8} _{µm(c)} ≥ 1000	β ₆ _{µm(c)} ≥ 1000	β ₂₃ _{µm(c)} ≥ 1000	β ₁₁ _{µm(c)} ≥ 1000		
FIK20	Assembly	without predrilled holes	RMF	RMF	RMF	RMF	RMF	RMF	RMF	RMF
	Mix&Match		20	K030212 P171505 P766446	15	K030211 P171504 P766446	10	K030210 P171503 P766446	10	K030208 P171501 P766446
	Assembly	predrilled holes plugged	20	K030329 P171500 P766446	15	K030331 P171504 P766446	10	K030379 P171503 P766446	10	K030378 P171501 P766446
	Mix&Match									
FIK30	Assembly	without predrilled holes	30	K030213 P171500 P766447	20	K030217 P171504 P766447	20	K030216 P171503 P766447	15	K030214 P171501 P766447
	Mix&Match		30	K030333 P171500 P766447	20	K030336 P171504 P766447	20	K030335 P171503 P766447	15	K030334 P171501 P766447
	Assembly	predrilled holes plugged	50	K040506 P171518 P766448	35	K040510 P171522 P766448	35	K040509 P171521 P766448	30	K040507 P171519 P766448
	Mix&Match									
FIK50	Assembly	without predrilled holes	50	K040868 P171512 P766448	35	K040866 P171522 P766448	35	K040865 P171521 P766448	30	K040864 P171519 P766448
	Mix&Match		50	K040872 P171529 P766449	40	K040516 P171528 P766449	40	K040515 P171527 P766449	35	K040513 P171525 P766449
	Assembly	predrilled holes plugged	60	K040873 P171524 P766449	60	K040871 P171528 P766449	40	K040870 P171527 P766449	35	K040869 P171525 P766449
	Mix&Match									
FIK60	Assembly	without predrilled holes	80	K040518 P171530 P766450	80	K040523 P171535 P766450	55	K040521 P171533 P766450	50	K040519 P171531 P766450
	Mix&Match		80	K040878 P171530 P766450	80	K040877 P171535 P766450	55	K040875 P171533 P766450	50	K040885 P171531 P766450
	Assembly	predrilled holes plugged	100	K040500 P171530 P766451	100	K040505 P171535 P766451	65	K040504 P171534 P766451	60	K040501 P171531 P766451
	Mix&Match									
FIK100	Assembly	without predrilled holes	100	K040884 P171530 P766451	100	K040883 P171535 P766451	65	K040882 P171534 P766451	60	K040879 P171531 P766451
	Mix&Match		100	K040884 P171530 P766451	100	K040883 P171535 P766451	65	K040882 P171534 P766451	60	K040879 P171531 P766451
	Assembly	predrilled holes plugged	100	K040884 P171530 P766451	100	K040883 P171535 P766451	65	K040882 P171534 P766451	60	K040879 P171531 P766451
	Mix&Match									

Return Line Filters

Low Pressure Filters In-Tank FIK-FIO



		WIRED MESH			CELLULOSE MEDIA			SYNTHETIC MEDIA								
		/6			/3			/1			/03			/02		
		60µm			β _{0.8} ≥ 1000			β _{0.6} ≥ 1000			β ₂₃ ≥ 1000			β ₁₁ ≥ 1000		
FIK150	Assembly	150	K051109	K051114	100	K051113	K051112	100	K051112	90	K051110	90	K051110	K051110		
			P171536	P766452	P171540	P766452	P171539	P766452	P171538	P766452	P171537	P766452				
	Assembly	150	K051238	K051237	100	K051236	K051235	100	K051235	90	K051233	90	K051233	P766452		
			P171536	P766452	P171540	P766452	P171539	P766452	P171538	P766452	P171537	P766452				
	Assembly	180	K051115	K051120	120	K051119	K051118	120	K051118	110	K051116	110	K051116	K051116		
			P171536	P766453	P171540	P766453	P171539	P766453	P171538	P766453	P171537	P766453				
Assembly	180	K051242	K051241	120	K051229	K051232	120	K051232	110	K051239	110	K051239	K051239			
		P171536	P766453	P171540	P766453	P171539	P766453	P171538	P766453	P171537	P766453					
FIK200	Assembly	200	K070003	K070008	140	K070007	K070006	140	K070006	130	K070004	130	K070004	K070004		
			P171542	P766454	P171546	P766454	P171545	P766454	P171544	P766454	P171543	P766454				
	Assembly	200	K070280	K070285	140	K070284	K070283	140	K070283	130	K070281	130	K070281	K070281		
			P171542	P766454	P171546	P766454	P171545	P766454	P171544	P766454	P171543	P766454				
	Assembly	250	K070009	K070014	160	K070013	K070012	160	K070012	140	K070010	140	K070010	K070010		
			P171548	P766455	P171552	P766455	P171551	P766455	P171550	P766455	P171549	P766455				
Assembly	250	K070286	K070290	160	K070289	K070288	160	K070288	140	K070355	140	K070355	K070355			
		P171548	P766455	P171552	P766455	P171551	P766455	P171550	P766455	P171549	P766455					
FIK325	Assembly	330	K070015	K070020	200	K070019	K070018	200	K070018	180	K070016	180	K070016	K070016		
			P171554	P766456	P171558	P766456	P171557	P766456	P171556	P766456	P171555	P766456				
	Assembly	330	K070291	K070295	200	K070294	K070293	200	K070293	180	K070356	180	K070356	K070356		
			P171554	P766456	P171558	P766456	P171557	P766456	P171556	P766456	P171555	P766456				
	Assembly	330	K070021	K070026	200	K070025	K070024	200	K070024	180	K070022	180	K070022	K070022		
			P171560	P766457	P171564	P766457	P171563	P766457	P171562	P766457	P171561	P766457				
Assembly	330	K070296	K070301	200	K070300	K070299	200	K070299	180	K070297	180	K070297	K070297			
		P171560	P766457	P171564	P766457	P171563	P766457	P171562	P766457	P171561	P766457					

Return Line Filters

Low Pressure Filters In-Tank FIK-FIO



		WIRE MESH				CELLULOSE MEDIA				SYNTHETIC MEDIA			
		/09		/6		/3		/1		/03		/02	
		90µm		60µm		IS8 _{µm(e) ≥ 1000}		IS6 _{µm(e) ≥ 1000}		IS23 _{µm(e) ≥ 1000}		IS11 _{µm(e) ≥ 1000}	
FIK500	Assembly	500		500	400	K070031	K070030	400	K070030	350		350	K070028
	Mix&Match	P171566 P766458	P171571 P766458	P171571 P766458	P171570 P766458	P171569 P766458	P171569 P766458	P171569 P766458	P171568 P766458	P171568 P766458	P171567 P766458	P171567 P766458	P171567 P766458
	Assembly	500		500	400	K070302	K070305	400	K070305	350		350	K070303
	Mix&Match	P171566 P766458	P171571 P766458	P171571 P766458	P171570 P766458	P171569 P766458	P171569 P766458	P171569 P766458	P171568 P766458	P171568 P766458	P171567 P766458	P171567 P766458	P171567 P766458
FIK600	Assembly	600		600	500	K070033	K070036	500	K070036	400		400	K070034
	Mix&Match	P171572 P766459	P171577 P766459	P171577 P766459	P171576 P766459	P171575 P766459	P171575 P766459	P171575 P766459	P171574 P766459	P171574 P766459	P171573 P766459	P171573 P766459	P171573 P766459
	Assembly	600		600	500	K070308	K070310	500	K070309	400		400	K070277
	Mix&Match	P171572 P766459	P171577 P766459	P171577 P766459	P171576 P766459	P171575 P766459	P171575 P766459	P171575 P766459	P171574 P766459	P171574 P766459	P171573 P766459	P171573 P766459	P171573 P766459
FIK600 SAE Flange	Assembly	600		600	500	K070045	K070048	500	K070048	400		400	K070046
	Mix&Match	P171572 P766460	P171577 P766460	P171577 P766460	P171576 P766460	P171575 P766460	P171575 P766460	P171575 P766460	P171574 P766460	P171574 P766460	P171573 P766460	P171573 P766460	P171573 P766460
	Assembly	600		600	500	K070358	K070318	500	K070317	400		400	K070364
	Mix&Match	P171572 P766460	P171577 P766460	P171577 P766460	P171576 P766460	P171575 P766460	P171575 P766460	P171575 P766460	P171574 P766460	P171574 P766460	P171573 P766460	P171573 P766460	P171573 P766460
FIK800	Assembly	800		800	600	K070039	K070044	600	K070042	500		500	K070040
	Mix&Match	P171578 P766461	P171583 P766461	P171583 P766461	P171582 P766461	P171581 P766461	P171581 P766461	P171581 P766461	P171580 P766461	P171580 P766461	P171579 P766461	P171579 P766461	P171579 P766461
	Assembly	800		800	600	K070359	K070315	600	K070314	500		500	K070312
	Mix&Match	P171578 P766461	P171583 P766461	P171583 P766461	P171582 P766461	P171581 P766461	P171581 P766461	P171581 P766461	P171580 P766461	P171580 P766461	P171579 P766461	P171579 P766461	P171579 P766461
FIK800 SAE Flange	Assembly	800		800	600	K070051	K070055	600	K070054	500		500	K070052
	Mix&Match	P171578 P766462	P171583 P766462	P171583 P766462	P171582 P766462	P171581 P766462	P171581 P766462	P171581 P766462	P171580 P766462	P171580 P766462	P171579 P766462	P171579 P766462	P171579 P766462
	Assembly	800		800	600	K070363	K070321	600	K070320	500		500	K070360
	Mix&Match	P171578 P766462	P171583 P766462	P171583 P766462	P171582 P766462	P171581 P766462	P171581 P766462	P171581 P766462	P171580 P766462	P171580 P766462	P171579 P766462	P171579 P766462	P171579 P766462
		Sparepart	Housing	Sparepart	Housing	Sparepart	Housing	Sparepart	Housing	Sparepart	Housing	Sparepart	Housing

RMF = Recommended Maximum Flow in liters/minute with use of standard head. non-stock item; MOQ is 25 pcs; ordering only possible via your salescontact

Stock item (check e-commerce for availability)

Return Line Filters

Return Filters In-Tank FIK F10T



Family	WIREF MESH		CELLULOSE MEDIA						SYNTHETIC MEDIA					
	/09	/06	/3		/1		/03		/02					
	90µm	60µm	β _{0.8} ≥1000		β _{0.6} ≥1000		β _{0.23} ≥1000		β ₁₁ ≥1000					
Version	Version	RMF	RMF	RMF	RMF	RMF	RMF	RMF	RMF	RMF	RMF	RMF	RMF	RMF
FIK20	Assembly	without predrilled holes	20	K030225	K030230	15	K030229	K030228	10	K030227	10	K030226		
	Mix&Match			P171505 P766463	P766463		P171504 P766463	P766463		P171502 P766463		P171501 P766463		
	Assembly	predrilled holes plugged	20	K030341	K030394	15	K030342	K030389	10	K030388	10	K030387		
	Mix&Match			P171500 P766463	P766463		P171504 P766463	P766463		P171502 P766463		P171501 P766463		
FIK30	Assembly	without predrilled holes	30	K030231	K030236	20	K030235	K030234	15	K030233	15	K030232		
	Mix&Match			P171500 P766464	P766464		P171504 P766464	P766464		P171502 P766464		P171501 P766464		
	Assembly	predrilled holes plugged	30	K030343	K030346	20	K030345	K030344	15	K030396	15	K030385		
	Mix&Match			P171500 P766464	P766464		P171504 P766464	P766464		P171502 P766464		P171501 P766464		
FIK50	Assembly	without predrilled holes	50	K040536	K040541	35	K040540	K040539	30	K040538	30	K040537		
	Mix&Match			P171518 P766465	P766465		P171522 P766465	P766465		P171520 P766465		P171519 P766465		
	Assembly	predrilled holes plugged	50	K040892	K040895	35	K040894	K040893	30	K040994	30	K040993		
	Mix&Match			P171518 P766465	P766465		P171522 P766465	P766465		P171520 P766465		P171519 P766465		
FIK60	Assembly	without predrilled holes	60	K040542	K040547	40	K040546	K040545	35	K040544	35	K040543		
	Mix&Match			P171524 P764666	P764666		P171528 P764666	P764666		P171526 P764666		P171525 P764666		
	Assembly	predrilled holes plugged	60	K040896	K040900	40	K040899	K040898	35	K040897	35	K041008		
	Mix&Match			P171524 P764666	P764666		P171528 P764666	P764666		P171526 P764666		P171525 P764666		
FIK80	Assembly	without predrilled holes	80	K040548	K040553	55	K040552	K040551	50	K040550	50	K040549		
	Mix&Match			P171530 P766467	P766467		P171534 P766467	P766467		P171532 P766467		P171531 P766467		
	Assembly	predrilled holes plugged	80	K040901	K040904	55	K040903	K040902	50	K041017	50	K041016		
	Mix&Match			P171530 P766467	P766467		P171534 P766467	P766467		P171532 P766467		P171531 P766467		
FIK100	Assembly	without predrilled holes	100	K040530	K040535	65	K040534	K040533	60	K040532	60	K040531		
	Mix&Match			P171530 P766468	P766468		P171534 P766468	P766468		P171532 P766468		P171531 P766468		
	Assembly	predrilled holes plugged	100	K040889	K040891	65	K040890	K040884	60	K041023	60	K040889		
	Mix&Match			P171530 P766468	P766468		P171534 P766468	P766468		P171532 P766468		P171531 P766468		

Return Line Filters

Return Filters In-Tank FIK FIOT



		WIRED MESH			CELLULOSE MEDIA			SYNTHETIC MEDIA		
		/09	/6	/3	/1	/03	/02			
		90µm	60µm	$\beta_{0.8} \geq 1000$	$\beta_{0.6} \geq 1000$	$\beta_{0.3} \geq 1000$	$\beta_{0.1} \geq 1000$			
FIK150	Assembly	150	150	100	100	90	90	90	90	K051123
	Mix&Match	P171536 P766469	K051127 P171541 P766469	K051126 P171540 P766469	K051125 P171539 P766469	K051124 P171538 P766469	K051123 P171537 P766469	K051122 P171536 P766469	K051121 P171535 P766469	P171537 P766469
	Assembly	150	150	100	100	90	90	90	90	K041029
	Mix&Match	P171536 P766469	K051243 P171541 P766469	K051246 P171540 P766469	K051245 P171539 P766469	K051244 P171538 P766469	K051243 P171537 P766469	K051242 P171536 P766469	K051241 P171535 P766469	P171537 P766469
FIK180	Assembly	180	180	120	120	120	110	110	110	K051129
	Mix&Match	P171536 P766470	K051128 P171541 P766470	K051132 P171540 P766470	K051131 P171539 P766470	K051130 P171538 P766470	K051129 P171537 P766470	K051128 P171536 P766470	K051127 P171535 P766470	P171537 P766470
	Assembly	180	180	120	120	120	110	110	110	K051249
	Mix&Match	P171536 P766470	K051248 P171541 P766470	K051250 P171540 P766470	K051231 P171539 P766470	K051263 P171538 P766470	K051263 P171538 P766470	K051262 P171537 P766470	K051261 P171536 P766470	P171537 P766470
FIK200	Assembly	200	200	140	140	140	130	130	130	K070058
	Mix&Match	K070057 P171542 P766471	K070062 P171547 P766471	K070061 P171546 P766471	K070060 P171545 P766471	K070059 P171544 P766471	K070058 P171543 P766471	K070057 P171542 P766471	K070056 P171541 P766471	P171543 P766471
	Assembly	200	200	140	140	140	130	130	130	K070459
	Mix&Match	K070458 P171542 P766471	K070461 P171547 P766471	K070460 P171546 P766471	K070322 P171545 P766471	K070319 P171544 P766471	K070318 P171543 P766471	K070317 P171542 P766471	K070316 P171541 P766471	P171543 P766471
FIK250	Assembly	250	250	160	160	160	140	140	140	K070064
	Mix&Match	K070063 P171548 P766472	K070068 P171553 P766472	K070067 P171552 P766472	K070066 P171551 P766472	K070065 P171550 P766472	K070064 P171549 P766472	K070063 P171548 P766472	K070062 P171547 P766472	P171549 P766472
	Assembly	250	250	160	160	160	140	140	140	K070463
	Mix&Match	K070462 P171548 P766472	K070325 P171553 P766472	K070324 P171552 P766472	K070323 P171551 P766472	K070322 P171550 P766472	K070321 P171549 P766472	K070320 P171548 P766472	K070319 P171547 P766472	P171549 P766472
FIK325	Assembly	330	330	200	200	200	180	180	180	K070070
	Mix&Match	K070069 P171554 P764673	K070074 P171559 P764673	K070073 P171558 P764673	K070072 P171557 P764673	K070071 P171556 P764673	K070070 P171555 P764673	K070069 P171554 P764673	K070068 P171553 P764673	P171555 P764673
	Assembly	330	330	200	200	200	180	180	180	K070326
	Mix&Match	K070465 P171554 P764673	K070330 P171559 P764673	K070329 P171558 P764673	K070328 P171557 P764673	K070327 P171556 P764673	K070326 P171555 P764673	K070325 P171554 P764673	K070324 P171553 P764673	P171555 P764673
FIK330	Assembly	330	330	200	200	200	180	180	180	K070076
	Mix&Match	K070075 P171560 P766474	K070080 P171565 P766474	K070079 P171564 P766474	K070078 P171563 P766474	K070077 P171562 P766474	K070076 P171561 P766474	K070075 P171560 P766474	K070074 P171559 P766474	P171561 P766474
	Assembly	330	330	200	200	200	180	180	180	K070331
	Mix&Match	K070385 P171560 P766474	K070335 P171565 P766474	K070334 P171564 P766474	K070333 P171563 P766474	K070332 P171562 P766474	K070331 P171561 P766474	K070330 P171560 P766474	K070329 P171559 P766474	P171561 P766474

Return Line Filters

Return Filters In-Tank FIK FIOT



		WIPE MESH				CELLULOSE MEDIA				SYNTHETIC MEDIA			
		/09		/6		/3		/1		/03		/02	
		90µm		60µm		β ₈ _{µm} ≥ 1000		β ₆ _{µm} ≥ 1000		β ₂₃ _{µm} ≥ 1000		β ₁₁ _{µm} ≥ 1000	
FIK500	Assembly	K070081	K070086	500	400	K070085	400	K070084	350	K070083	350	K070082	
	Mix&Match	P171566 P766475	P171571 P766475		P171570 P766475	P171570 P766475		P171569 P766475		P171568 P766475		P171567 P766475	
	Assembly	K070366	K070339	500	400	K070338	400	K070337	350	K070367	350	K070336	
	Mix&Match	P171566 P766475	P171571 P766475		P171570 P766475	P171570 P766475		P171569 P766475		P171568 P766475		P171567 P766475	
FIK600	Assembly	K070087	K070092	600	500	K070091	500	K070090	400	K070089	400	K070088	
	Mix&Match	P171572 P766476	P171577 P766476		P171576 P766476	P171576 P766476		P171575 P766476		P171574 P766476		P171573 P766476	
	Assembly	K070343	K070454	600	500	K070342	500	K070341	400	K070369	400	K070340	
	Mix&Match	P171572 P766476	P171577 P766476		P171576 P766476	P171576 P766476		P171575 P766476		P171574 P766476		P171573 P766476	
FIK600 SAE Flange	Assembly	K070089	K070104	600	500	K070103	500	K070102	400	K070101	400	K070100	
	Mix&Match	P171572 P766477	P171577 P766477		P171576 P766477	P171576 P766477		P171575 P766477		P171574 P766477		P171573 P766477	
	Assembly	K070466	K070345	600	500	K070344	500	K070469	400	K070468	400	K070467	
	Mix&Match	P171572 P766477	P171577 P766477		P171576 P766477	P171576 P766477		P171575 P766477		P171574 P766477		P171573 P766477	
FIK800	Assembly	K070093	K070098	800	600	K070097	600	K070096	500	K070095	500	K070094	
	Mix&Match	P171578 P766478	P171583 P766478		P171582 P766478	P171582 P766478		P171581 P766478		P171580 P766478		P171579 P766478	
	Assembly	K070455	K070457	800	600	K070348	600	K070347	500	K070456	500	K070346	
	Mix&Match	P171578 P766478	P171583 P766478		P171582 P766478	P171582 P766478		P171581 P766478		P171580 P766478		P171579 P766478	
FIK800 SAE Flange	Assembly	K070105	K070110	800	600	K070109	600	K070108	500	K070107	500	K070106	
	Mix&Match	P171578 P766479	P171583 P766479		P171582 P766479	P171582 P766479		P171581 P766479		P171580 P766479		P171579 P766479	
	Assembly	K070470		800	600	K070742	600	K070350	500	K070471	500	K070349	
	Mix&Match	P171578 P766479	P171583 P766479		P171582 P766479	P171582 P766479		P171581 P766479		P171580 P766479		P171579 P766479	

RMF = Recommended Maximum Flow in liters/minute with use of standard housing. non-stock item; MOQ is 25 pcs; ordering only possible via your salescontact

Stock item (check e-commerce for availability)

Return Line Filters

Low Pressure Filters In-Tank FIK-FIO/FIOT (4 holes flanges)



		WIRED MESH				CELLULOSE MEDIA				SYNTHETIC MEDIA			
		/09	/6	/3	/1	/03	/02						
		90µm	60µm	β _{0.6} µm(e) ≥ 1000	β _{0.6} µm(e) ≥ 1000	β _{2.0} µm(e) ≥ 1000	β _{1.0} µm(e) ≥ 1000						
Family	Version	RMF		RMF		RMF		RMF		RMF		RMF	
FIK 4 110	Version	110		110		65		65		60		60	
	Assembly	K051560	K041561	K041562	K041563	K041564	K041565	K041564	K041564	K041564	K041565	K041565	K041565
	Mix&Match	P171530 P766451	P171535 P766451	P171534 P766451	P171533 P766451	P171532 P766451	P171531 P766451	P171532 P766451	P171532 P766451	P171532 P766451	P171531 P766451	P171531 P766451	P171531 P766451
	Assembly	K041536	K041538	K041538	K041539	K041540	K041541	K041540	K041540	K041540	K041541	K041541	K041541
FIK 4 140	Version	140		140		100		100		90		90	
	Assembly	K041566	K041567	K041568	K041569	K041570	K041571	K041570	K041570	K041570	K041571	K041571	K041571
	Mix&Match	P171831 P766675	P171834 P766675	P171837 P766675	P171840 P766675	P171843 P766675	P171846 P766675	P171843 P766675	P171843 P766675	P171843 P766675	P171846 P766675	P171846 P766675	P171846 P766675
	Assembly	K041542	K041543	K041544	K041545	K041546	K041547	K041546	K041546	K041546	K041547	K041547	K041547
FIK 4 140	Version	140		140		100		100		90		90	
	Assembly	K041572	K041573	K041574	K041575	K041576	K041577	K041576	K041576	K041576	K041577	K041577	K041577
	Mix&Match	P171530 P766468	P171535 P766468	P171534 P766468	P171533 P766468	P171532 P766468	P171531 P766468	P171532 P766468	P171532 P766468	P171532 P766468	P171531 P766468	P171531 P766468	P171531 P766468
	Assembly	K041548	K041549	K041550	K041551	K041552	K041553	K041552	K041552	K041552	K041553	K041553	K041553
FIK 4 140	Version	140		140		100		100		90		90	
	Assembly	K041578	K041579	K041580	K041581	K041582	K041583	K041582	K041582	K041582	K041583	K041583	K041583
	Mix&Match	P171831 P766674	P171834 P766674	P171837 P766674	P171840 P766674	P171843 P766674	P171846 P766674	P171843 P766674	P171843 P766674	P171843 P766674	P171846 P766674	P171846 P766674	P171846 P766674
	Assembly	K041554	K041555	K041556	K041557	K041558	K041559	K041558	K041558	K041558	K041559	K041559	K041559
FIK 4 140	Version	140		140		100		100		90		90	
	Assembly	P171831 P766674	P171834 P766674	P171837 P766674	P171840 P766674	P171843 P766674	P171846 P766674	P171843 P766674	P171843 P766674	P171843 P766674	P171846 P766674	P171846 P766674	P171846 P766674
	Mix&Match	P171831 P766674	P171834 P766674	P171837 P766674	P171840 P766674	P171843 P766674	P171846 P766674	P171843 P766674	P171843 P766674	P171843 P766674	P171846 P766674	P171846 P766674	P171846 P766674
	Assembly	Sparepart	Housing	Sparepart	Housing	Sparepart	Housing	Sparepart	Housing	Sparepart	Housing	Sparepart	Housing

RMF = Recommended Maximum Flow in liters/minute with use of standard head. non-stock item; MOQ is 25 pcs; ordering only possible via your salescontact

Stock item (check e-commerce for availability)

Return Line Filters

Return Filters In-Tank FIK FIS



Family	Element	Version	Version	WIREF MESH			CELLULOSE MEDIA			SYNTHETIC MEDIA			
				/9	/6	/3	/1	/3	/1	/3	/3	/1	/3
				90µm	60µm	β _{0.8} ≥1000	β _{0.6} ≥1000	β _{0.6} ≥1000	β _{0.6} ≥1000	β _{0.6} ≥1000	β _{0.6} ≥1000	β _{0.6} ≥1000	β _{0.6} ≥1000
FIS20	CR20	Assembly	RMF	K030304	RMF	K030306	RMF	K030310	RMF	K030312	RMF	K030314	
		Mix&Match	without predrilled holes	P171829	P766618	P171832	P766618	P171838	P766618	P171841	P766618	P171844	P766618
		Assembly	predrilled holes plugged	K030524	20	K030529	15	K030527	10	K030526	10	K030525	
		Mix&Match		P171829	P766618	P171832	P766618	P171838	P766618	P171841	P766618	P171844	P766618
FIS40	CR40	Assembly	RMF	K030305		K030307		K030311		K030313		K030315	
		Mix&Match	without predrilled holes	P171830	P766619	P171833	P766619	P171839	P766619	P171842	P766619	P171845	P766619
		Assembly	predrilled holes plugged	K030530	40	K030535	30	K030533	25	K030532	25	K030531	
		Mix&Match		P171830	P766619	P171833	P766619	P171839	P766619	P171842	P766619	P171845	P766619
FIS60	CR60	Assembly	RMF	K040758		K040761		K040767		K040770		K040773	
		Mix&Match	without predrilled holes	P171524	P766597	P171529	P766597	P171527	P766597	P171526	P766597	P171525	P766597
		Assembly	predrilled holes plugged	K041337	60	K041342	40	K041340	35	K041339	35	K041338	
		Mix&Match		P171524	P766597	P171529	P766597	P171527	P766597	P171526	P766597	P171525	P766597
FIS100	CR100	Assembly	RMF	K040759		K040762		K040768		K040771		K040774	
		Mix&Match	without predrilled holes	P171530	P766598	P171535	P766598	P171533	P766598	P171532	P766598	P171531	P766598
		Assembly	predrilled holes plugged	K041319	100	K041329	65	K041322	60	K041321	60	K041320	
		Mix&Match		P171530	P766598	P171535	P766598	P171533	P766598	P171532	P766598	P171531	P766598
FIS150	CR150	Assembly	RMF	K040760		K040763		K040769		K040772		K040775	
		Mix&Match	without predrilled holes	P171831	P766599	P171834	P766599	P171840	P766599	P171843	P766599	P171846	P766599
		Assembly	predrilled holes plugged	K041330	150	K041336	120	K041334	110	K041332	110	K041331	
		Mix&Match		P171831	P766599	P171834	P766599	P171840	P766599	P171843	P766599	P171846	P766599
		Sparepart	Housing			P171837	P766599	Sparepart	Housing				
		Sparepart	Housing			P171837	P766599	Sparepart	Housing				

RMF = Recommended Maximum Flow in liters/minute with use of standard housing. non-stock item; MOQ is 25 pcs; ordering only possible via your salescontact.

Stock item (check e-commerce for availability) .Please bare in mind the Restyling on FIS 60-100-150-200

Return Line Filters

Return Filters In-Line FIK FLS



		WIRED MESH			CELLULOSE MEDIA			SYNTHETIC MEDIA		
		/09	/6	/3	/1	/03	/02			
		90µm	60µm	$\beta_{10} \geq 1000$	$\beta_{10} \geq 1000$	$\beta_{23} \geq 1000$	$\beta_{11} \geq 1000$			
Family	Version	RMF	RMF	RMF	RMF	RMF	RMF	RMF	RMF	RMF
FLS 50	Version									
	without predrilled holes	K030259	K030264	K030263	K030262	K030261	K030260			
	Mix&Match	P171518 P766995	P171523 P766995	P171522 P766995	P171521 P766995	P171520 P766995	P171519 P766995			
	with predrilled holes	K030372	K030325	K030376	K030375	K030374	K030373			
FLS100	Version									
	without predrilled holes	K030271	K030276	K030275	K030274	K030273	K030272			
	Mix&Match	P171530 P766996	P171535 P766996	P171534 P766996	P171533 P766996	P171532 P766996	P171531 P766996			
	with predrilled holes	K030385	K030371	K030326	K030388	K030367	K030386			
FLS 150	Version									
	without predrilled holes	P171530 P766673	P171535 P766673	P171534 P766673	P171533 P766673	P171532 P766673	P171531 P766673			
	Mix&Match	K040596	K040601	K040600	K040599	K040598	K040597			
	with predrilled holes	P171584 P766997	P171589 P766997	P171588 P766997	P171587 P766997	P171586 P766997	P171585 P766997			
FLS180	Version									
	without predrilled holes	K040968	K040953	K040952	K040951	K040950	K040949			
	Mix&Match	P171584 P766671	P171589 P766671	P171588 P766671	P171587 P766671	P171586 P766671	P171585 P766671			
	with predrilled holes	K040608	K040613	K040612	K040611	K040610	K040609			
FLS200	Version									
	without predrilled holes	P171536 P766998	P171541 P766998	P171540 P766998	P171539 P766998	P171538 P766998	P171537 P766998			
	Mix&Match	K040954	K040959	K040958	K040957	K040956	K040955			
	with predrilled holes	P171536 P766670	P171541 P766670	P171540 P766670	P171539 P766670	P171538 P766670	P171537 P766670			
FLS250	Version									
	without predrilled holes	K040620	K040625	K040624	K040623	K040622	K040621			
	Mix&Match	P171596 P766999	P171601 P766999	P171600 P766999	P171599 P766999	P171598 P766999	P171597 P766999			
	with predrilled holes	K040960	K040963	K040962	K040961	K041125	K041124			
FLS330	Version									
	without predrilled holes	P171596 P766666	P171601 P766666	P171600 P766666	P171599 P766666	P171598 P766666	P171597 P766666			
	Mix&Match	K070159	K070164	K070163	K070162	K070161	K070160			
	with predrilled holes	P171590 P767000	P171595 P767000	P171594 P767000	P171593 P767000	P171592 P767000	P171591 P767000			

Return Line Filters

Return Filters In-Line FIK FLS



		WIRE MESH				CELLULOSE MEDIA				SYNTHETIC MEDIA			
		/09		/6		/3		/1		/03		/02	
		90µm		60µm		88 µm _{IC} ≥1000		86 µm _{IC} ≥1000		823 µm _{IC} ≥1000		811 µm _{IC} ≥1000	
FLS500	Assembly	K070183	K070188	K070188	K070187	K070186	K070185	K070185	K070184	K070184	K070184	K070184	K070184
	Mix&Match	P171566 P767004	P171571 P767004	P171570 P767004	P171570 P767004	P171569 P767004	P171568 P767004	P171568 P767004	P171567 P767004	P171567 P767004	P171567 P767004	P171567 P767004	P171567 P767004
	Assembly	K070426	K070431	K070430	K070430	K070429	K070428	K070428	K070427	K070427	K070427	K070427	K070427
	Mix&Match	P171566 P766665	P171571 P766665	P171570 P766665	P171570 P766665	P171569 P766665	P171568 P766665	P171568 P766665	P171567 P766665	P171567 P766665	P171567 P766665	P171567 P766665	P171567 P766665
FLS250 SAE Flange	Assembly	K070195	K070200	K070200	K070199	K070198	K070197	K070197	K070196	K070196	K070196	K070196	K070196
	Mix&Match	P171590 P767001	P171595 P767001	P171594 P767001	P171594 P767001	P171593 P767001	P171592 P767001	P171592 P767001	P171591 P767001	P171591 P767001	P171591 P767001	P171591 P767001	P171591 P767001
	Assembly	K070432	K070433	K070433	K070433	K070433	K070433	K070433	K070432	K070432	K070432	K070432	K070432
	Mix&Match	P171590 P766663	P171595 P766663	P171594 P766663	P171594 P766663	P171593 P766663	P171592 P766663	P171592 P766663	P171591 P766663	P171591 P766663	P171591 P766663	P171591 P766663	P171591 P766663
FLS330 SAE Flange	Assembly	K070207	K070212	K070212	K070211	K070210	K070209	K070209	K070208	K070208	K070208	K070208	K070208
	Mix&Match	P171560 P767003	P171565 P767003	P171564 P767003	P171564 P767003	P171563 P767003	P171562 P767003	P171562 P767003	P171561 P767003	P171561 P767003	P171561 P767003	P171561 P767003	P171561 P767003
	Assembly	K070569	K070568	K070568	K070434	K070567	K070566	K070566	K070565	K070565	K070565	K070565	K070565
	Mix&Match	P171560 P766662	P171565 P766662	P171564 P766662	P171564 P766662	P171563 P766662	P171562 P766662	P171562 P766662	P171561 P766662	P171561 P766662	P171561 P766662	P171561 P766662	P171561 P766662
FLS500 SAE Flange	Assembly	K070219	K070224	K070224	K070223	K070222	K070221	K070221	K070220	K070220	K070220	K070220	K070220
	Mix&Match	P171566 P767005	P171571 P767005	P171570 P767005	P171570 P767005	P171569 P767005	P171568 P767005	P171568 P767005	P171567 P767005	P171567 P767005	P171567 P767005	P171567 P767005	P171567 P767005
	Assembly	K070571	K070439	K070439	K070438	K070437	K070436	K070436	K070435	K070435	K070435	K070435	K070435
	Mix&Match	P171566 P766668	P171571 P766668	P171570 P766668	P171570 P766668	P171569 P766668	P171568 P766668	P171568 P766668	P171567 P766668	P171567 P766668	P171567 P766668	P171567 P766668	P171567 P766668
FLS800 SAE Flange	Assembly	K070231	K070236	K070236	K070235	K070234	K070233	K070233	K070232	K070232	K070232	K070232	K070232
	Mix&Match	P171578 P767006	P171583 P767006	P171582 P767006	P171582 P767006	P171581 P767006	P171580 P767006	P171580 P767006	P171579 P767006	P171579 P767006	P171579 P767006	P171579 P767006	P171579 P767006
	Assembly	K070440	K070445	K070445	K070444	K070443	K070442	K070442	K070441	K070441	K070441	K070441	K070441
	Mix&Match	P171578 P766664	P171583 P766664	P171582 P766664	P171582 P766664	P171581 P766664	P171580 P766664	P171580 P766664	P171579 P766664	P171579 P766664	P171579 P766664	P171579 P766664	P171579 P766664
	Sparepart	Housing	Housing	Housing	Housing	Housing	Housing	Housing	Housing	Housing	Housing	Housing	
	Sparepart	Housing	Housing	Housing	Housing	Housing	Housing	Housing	Housing	Housing	Housing	Housing	

RMF = Recommended Maximum Flow in liters/minute with use of standard housing. non-stock item; MOQ is 25 pcs; ordering only possible via your salescontact

Stock item (check e-commerce for availability)

Return Line Filters

Low Pressure Filters In-Line FBK-FRCA



		WIRES MESH MEDIA			CELLULOSE MEDIA			SYNTHETIC MEDIA			BOX						
		/6			/3			/1			/03			/02			
		60µm			$\beta_{90\mu m} \geq 1000$			$\beta_{90\mu m} \geq 1000$			$\beta_{25\mu m} \geq 1000$			$\beta_{10\mu m} \geq 1000$			
Family	Version	RMF		RMF		RMF		RMF		RMF		RMF		RMF			
FRCA60	Assembly	60	K040635		K040634		K040633		K040632		K040631						
	Mix&Match		P171607	P173441	60	P171606	P173441	50	P550288	P173441	40	P171604	P173441	40	P171602	P173441	E509389
FRCA80	Assembly	80	K040645		K040644		K040643		K040642		K040641						
	Mix&Match		P171612	P173441	70	P171611	P173441	60	P171610	P173441	50	P171609	P173441	50	P171608	P173441	E771397
FRCA108																	
FRCA118																	
FRCA160	Assembly	160	K051155		K051154		K051153		K051152		K051151						
	Mix&Match		P171617	P176846	150	P171616	P176846	140	P550148	P176846	120	P171614	P176846	120	P171613	P176846	E771403
FRCA200	Assembly	200	K051165		K051164		K051163		K051162		K051161						
	Mix&Match		P171622	P176846	190	P171621	P176846	160	P171620	P176846	140	P171619	P176846	140	P171618	P176846	E771404
FRCA380	Assembly	380	K250035		K250034		K250033		K250032		K250031						
	Mix&Match		P171617	P176293	340	P171616	P176293	300	P550148	P176293	280	P171614	P176293	280	P171613	P176293	E771406
FRCA400	Assembly	400	K250040		K250039		K250038		K250037		K250036						
	Mix&Match		P171622	P176293	360	P171621	P176293	320	P171620	P176293	300	P171619	P176293	300	P171618	P176293	E507967
FRCA220																	
FRCA250																	

RMF = Recommended Maximum Flow in liters/minute with use of standard housing. non-stock item; not order-able via e-Commerce - ordering only possible via your salescontact; MOQ is 25 pcs

Stock item (check e-commerce for availability)

Return & Suction Filters

Low Pressure Filters In-Tank FHK-FIR



Family	Version	WIRED MESH			CELLULOSE MEDIA			SYNTHETIC MEDIA			
		/9	/6	/3	/1	/03	XP10				
FHK 30	Assembly	RMF	60µm	$\beta_{9, \mu m} \geq 1000$	$\beta_{6, \mu m} \geq 1000$	$\beta_{23, \mu m} \geq 1000$	$\beta_{11, \mu m} \geq 1000$				
	Mix&Match	30	K030352	20	K030245	20	K030244	15	K030428	15	
			P171505 P766679	P171504 P766679	P171503 P766679	P171502 P766679	P171501 P766679				
FHK 60	Assembly	RMF	60µm	$\beta_{9, \mu m} \geq 1000$	$\beta_{6, \mu m} \geq 1000$	$\beta_{23, \mu m} \geq 1000$	$\beta_{11, \mu m} \geq 1000$				
	Mix&Match	60	K040917	40	K040564	40	K040563	35	K040562	35	
			P171529 P766481	P171528 P766481	P171527 P766481	P171526 P766481	P171525 P766481				
FHK 100	Assembly	RMF	60µm	$\beta_{9, \mu m} \geq 1000$	$\beta_{6, \mu m} \geq 1000$	$\beta_{23, \mu m} \geq 1000$	$\beta_{11, \mu m} \geq 1000$				
	Mix&Match	100	K040571	65	K040570	65	K040569	60	K040568	60	
			P171535 P766482	P171534 P766482	P171533 P766482	P171532 P766482	P171531 P766482				
FHK 180	Assembly	RMF	60µm	$\beta_{9, \mu m} \geq 1000$	$\beta_{6, \mu m} \geq 1000$	$\beta_{23, \mu m} \geq 1000$	$\beta_{11, \mu m} \geq 1000$				
	Mix&Match	180	K051139	120	K051138	120	K051137	110	K051136	110	
			P171541 P766678	P171540 P766678	P171539 P766678	P171538 P766678	P171537 P766678				
FHK 500	Assembly	RMF	60µm	$\beta_{9, \mu m} \geq 1000$	$\beta_{6, \mu m} \geq 1000$	$\beta_{23, \mu m} \geq 1000$	$\beta_{11, \mu m} \geq 1000$				
	Mix&Match	500	K070380	400	K070121	400	K070120	350	K070119	350	
			P171571 P766483	P171570 P766483	P171569 P766483	P171568 P766483	P171567 P766483				
		Sparepart	Housing	Sparepart	Housing	Sparepart	Housing	Sparepart	Housing	Sparepart	Housing

RMF = Recommended Maximum Flow in liters/minute with use of standard housing. non-stock item; MOQ is 25 pcs; ordering only possible via your salescontact

Stock item (check e-commerce for availability)

Suction Line Filters

Suction Filters In-Line FLK FLA



Family	Version	Version	WIRED MESH			CELLULOSE MEDIA			SYNTHETIC MEDIA				
			/09	/06	/03	/1	/03	/03	XP10				
			90µm	60µm	IS ₉ ≥1000 µm(e)	IS ₆ ≥1000 µm(e)	IS ₂₃ ≥1000 µm(e)	IS ₁₁ ≥1000 µm(e)					
FLA 50	Assembly	Version	RMF										
	Mix&Match	without predrilled holes		K030253									
	Assembly	with predrilled holes	20	P171518 P766484 K030361									
	Mix&Match			P171518 P766484									
FLA100	Assembly	without predrilled holes		K030265									
	Mix&Match		40	P171530 P766485 K030356									
	Assembly	with predrilled holes		P171530 P766485									
	Mix&Match			P171530 P766485									
FLA150	Assembly	without predrilled holes		K040590									
	Mix&Match		65	P171584 P766486 K040932									
	Assembly	with predrilled holes		P171584 P766486									
	Mix&Match			P171584 P766486									
FLA180	Assembly	without predrilled holes		K040602									
	Mix&Match		90	P171536 P766487 K040937									
	Assembly	with predrilled holes		P171536 P766487									
	Mix&Match			P171536 P766487									
FLA200	Assembly	without predrilled holes		K040614									
	Mix&Match		100	P171596 P766488 K040942									
	Assembly	with predrilled holes		P171596 P766488									
	Mix&Match			P171596 P766488									
FLA250	Assembly	without predrilled holes		K070153									
	Mix&Match		125	P171590 P766489 K070396									
	Assembly	with predrilled holes		P171590 P766489									
	Mix&Match			P171590 P766489									
FLA330	Assembly	without predrilled holes		K070165									
	Mix&Match		170	P171560 P766491 K070400									
	Assembly	with predrilled holes		P171560 P766491									
	Mix&Match			P171560 P766491									

Suction Line Filters

Suction Filters In-Line FLK FLA



		WIREF MESH			CELLULOSE MEDIA			SYNTHETIC MEDIA		
		/09	/6	/3	/1	/03	XP10			
		90µm	60µm	β ₈ ≥1000	β ₆ ≥1000	β ₂₃ ≥1000	β ₁₁ ≥1000			
FLA500	Assembly	K070177	K070182	K070181	K070180	K070179	K070178			
	Mix&Match	P171566 P766493	P171571 P766493	P171570 P766493	P171569 P766493	P171568 P766493	P171567 P766493			
	Assembly	K070405	K070410	K070409	K070408	K070407	K070406			
	Mix&Match	P171566 P766493	P171571 P766493	P171570 P766493	P171569 P766493	P171568 P766493	P171567 P766493			
FLA250 SAE Flange	Assembly	K070189	K070194	K070193	K070192	K070191	K070190			
	Mix&Match	P171590 P766490	P171595 P766490	P171594 P766490	P171593 P766490	P171592 P766490	P171591 P766490			
	Assembly	K070503	K070502	K070501	K070500	K070499	K070498			
	Mix&Match	P171590 P766490	P171595 P766490	P171594 P766490	P171593 P766490	P171592 P766490	P171591 P766490			
FLA330 SAE Flange	Assembly	K070201	K070206	K070205	K070204	K070203	K070202			
	Mix&Match	P171560 P766492	P171565 P766492	P171564 P766492	P171563 P766492	P171562 P766492	P171561 P766492			
	Assembly	K070510	K070509	K070508	K070507	K070506	K070505			
	Mix&Match	P171560 P766492	P171565 P766492	P171564 P766492	P171563 P766492	P171562 P766492	P171561 P766492			
FLA500 SAE Flange	Assembly	K070213	K070218	K070217	K070216	K070215	K070214			
	Mix&Match	P171566 P766494	P171571 P766494	P171570 P766494	P171569 P766494	P171568 P766494	P171567 P766494			
	Assembly	K070515	K070411	K070514	K070513	K070512	K070511			
	Mix&Match	P171566 P766494	P171571 P766494	P171570 P766494	P171569 P766494	P171568 P766494	P171567 P766494			
FLA800 SAE Flange	Assembly	K070225	K070230	K070229	K070228	K070227	K070226			
	Mix&Match	P171578 P766495	P171583 P766495	P171582 P766495	P171581 P766495	P171580 P766495	P171579 P766495			
	Assembly	K070412	K070416	K070415	K070414	K070517	K070516			
	Mix&Match	P171578 P766495	P171583 P766495	P171582 P766495	P171581 P766495	P171580 P766495	P171579 P766495			
		Sparepart	Housing	Sparepart	Housing	Sparepart	Housing			

RMF = Recommended Maximum Flow in liters/minute with use of standard head. non-stock item; MOQ is 25 pcs; ordering only possible via your salescontact

Stock item (check e-commerce for availability)

Suction Line Filters

Low Pressure Filters In-Line FBK-FACA



RMF = Recommended Maximum Flow in liters/minute with use of standard housing.
 non-stock item; MOQ is 25 pcs; ordering only possible via your salescontact

Stock item (check e-commerce for availability)

Family	Version	WIRED MESH MEDIA			CELLULOSE MEDIA			SYNTHETIC MEDIA			Box
		/6	/3	/1	/3	/1	/3	/3	/2		
		60µm	$R_{90(\mu m)} \geq 1000$	$R_{25(\mu m)} \geq 1000$	$R_{90(\mu m)} \geq 1000$	$R_{25(\mu m)} \geq 1000$	$R_{1(\mu m)} \geq 1000$	$R_{25(\mu m)} \geq 1000$	$R_{1(\mu m)} \geq 1000$		
CA80	Assembly	RMF									
	Mix&Match		K040629	K040628	K040627	K040626					E509389
	Assembly	30	P171606 P173442	P550288 P173442	P171604 P173442	P171602 P173442	15	15			
	Mix&Match		K041141	K041140	K041139	K041138					E509389
CA80	Assembly										
	Mix&Match		K040639	K040638	K040637	K040636					E771397
	Assembly	35	P171611 P173442	P171610 P173442	P171609 P173442	P171608 P173442	20	20			
	Mix&Match		K040970	K041147	K041146	K041145					E771397
CA108											
CA118											
CA160	Assembly										
	Mix&Match		K041149	K051148	K051147	K051146					E771403
	Assembly	80	P171616 P173203	P550148 P173203	P171614 P173203	P171613 P173203	60	60			
	Mix&Match		K051334	K051230	K051333	K051332					E771403
CA200	Assembly										
	Mix&Match		P171616 P761259	P550148 P761259	P171614 P761259	P171613 P761259					E771404
	Assembly	100	K051159	K051158	K051157	K051156					
	Mix&Match		P171621 P173203	P171620 P173203	P171619 P173203	P171618 P173203	80	80			
CA380	Assembly										
	Mix&Match		K250004	K250003	K250002	K250001					E771406
	Assembly	190	P171616 P766294	P550148 P766294	P171614 P766294	P171613 P766294	150	150			
	Mix&Match		K250109	K250062	K250108	K250107					E771406
CA400	Assembly										
	Mix&Match		P171616 P761260	P550148 P761260	P171614 P761260	P171613 P761260					E507967
	Assembly	200	K250009	K250008	K250007	K250006					
	Mix&Match		P171621 P766294	P171620 P766294	P171619 P766294	P171618 P766294	180	180			
CA220	Assembly										
	Mix&Match		K250116	K250115	K250114	K250113					E507967
	Assembly	100	P171621 P761260	P171620 P761260	P171619 P761260	P171618 P761260					
	Mix&Match										
CA250	Sparepart	Head	Sparepart	Head	Sparepart	Head	Sparepart	Head	Sparepart	Head	

Pressure Line

Medium Pressure Filters In-Line HMK04



		SYNTHETIC MEDIA												Box													
		#10				#20				#7				XP10				XP05									
		$\beta_{2\mu m(d)} \geq 1000$				$\beta_{2\mu m(d)} \geq 1000$				$\beta_{2\mu m(d)} \geq 1000$				$\beta_{2\mu m(d)} \geq 1000$				$\beta_{2\mu m(d)} \geq 1000$									
Family	Assembly	Version	RMF	RMF	RMF	RMF	RMF	RMF	RMF	RMF	RMF	RMF	RMF	RMF	RMF	RMF	RMF	RMF	RMF	RMF	RMF	RMF	RMF	RMF	RMF		
K405	Mix&Match	no indicator installed	100	K045741	120	K045739	110	K045743	110	K045745	110	K045745	100	K045747	100	K045747	100	P165354	P165354	P165354	P165354	P165354	P165354	P165354	P165354	P165354	E509389
	Assembly	indicator P162400 installed	100	K045794	120	K045795	110	K045793	110	K045792	110	K045792	100	K045791	100	K045791	100	P164375	P164375	P164375	P164375	P164375	P164375	P164375	P164375	P164375	E509389
	Mix&Match	indicator P162400 installed	100	P163419	120	P165335	110	P164381	110	P164381	110	P164381	110	P164381	110	P164381	110	P164375	P164375	P164375	P164375	P164375	P164375	P164375	P164375	P164375	E509389
	Mix&Match	indicator P162696 installed	100	P163419	120	P165335	110	P164381	110	P164381	110	P164381	110	P164381	110	P164381	110	P164375	P164375	P164375	P164375	P164375	P164375	P164375	P164375	P164375	E509389
K409	Mix&Match	no indicator installed	110	K045742	140	K045740	130	K045744	130	K045746	130	K045746	120	K045748	120	K045748	120	P163324	P163324	P163324	P163324	P163324	P163324	P163324	P163324	P163324	E507971
	Assembly	indicator P162400 installed	110	P163324	140	P165338	130	P164384	130	P164378	130	P164378	120	P165332	120	P165332	120	P163324	P163324	P163324	P163324	P163324	P163324	P163324	P163324	P163324	E507971
K409	Mix&Match	indicator P162696 installed	110	K045809	140	K045810	130	K045808	130	K045807	130	K045807	120	K045806	120	K045806	120	P163324	P163324	P163324	P163324	P163324	P163324	P163324	P163324	P163324	E507971
	Assembly	indicator P162696 installed	110	P163324	140	P165338	130	P164384	130	P164378	130	P164378	120	P165332	120	P165332	120	P163324	P163324	P163324	P163324	P163324	P163324	P163324	P163324	P163324	E507971
			Sparepart	Head+Indicator		Sparepart	Head+Indicator		Sparepart	Head+Indicator		Sparepart	Head+Indicator		Sparepart	Head+Indicator		Sparepart	Head+Indicator		Sparepart	Head+Indicator		Sparepart	Head+Indicator		

RMF = Recommended Maximum Flow in liters/minute with use of standard head. non-stock item; MOQ is 25 pcs; ordering only possible via your salescontact

Stock item (check e-commerce for availability)

Pressure Line

Medium Pressure Filters In-Line HMK05



		SYNTHETIC MEDIA												Box								
		#10				#20				#7				XP10				XP05				
		$\beta_{25mic} \geq 1000$				$\beta_{30mic} \geq 1000$				$\beta_{25mic} \geq 1000$				$\beta_{30mic} \geq 1000$				$\beta_{75mic} \geq 1000$				
Family	Version	RMF		RMF		RMF		RMF		RMF		RMF		RMF		RMF		RMF		RMF		
HMK513	no indicator installed	K053124	P165705	P766297	K053123	P165672	P766297	K053125	P165569	P766297	K053126	P165659	P766297	K053127	P165675	P766297	K053140	P165659	P766299+P162400	P165675	P766298	E771405
	indicator P162400 installed	K053143	100		K053144	120		K053142	110		K053141	110		K053145	100		K053140	100		K053145	E771405	
	indicator P162400 installed	P766299+P162400	100		P766299+P162400	120		P766299+P162400	110		P766299+P162400	110		P766299+P162400	100		P766299+P162400	100		P766299+P162400	E771405	
	no indicator installed	K053147	100		K053148	120		K053146	110		K053132	110		K053145	100		K053145	100		K053145	E771405	
	indicator P162696 installed	P766298	100		P766298	120		P766298	110		P766298	110		P766298	100		P766298	100		P766298	E771405	
			Sparepart	Head+Indicator		Sparepart	Head+Indicator		Sparepart	Head+Indicator		Sparepart	Head+Indicator		Sparepart	Head+Indicator		Sparepart	Head+Indicator		Sparepart	Head+Indicator

RMF = Recommended Maximum Flow in liters/minute with use of standard head. non-stock item; MOQ is 25 pcs; ordering only possible via your salescontact

Stock item (check e-commerce for availability)

Pressure Line

High Pressure Filters In-Line FPK02



SYNTHETIC MEDIA													
		/03 $\beta_{23} \geq 1000$			/02 $\beta_{11} \geq 1000$			/01 $\beta_8 \geq 1000$			/00 $\beta_6 \geq 1000$		
Family	Version	RMF		RMF		RMF		RMF		RMF			
AP358	Assembly	30	K020104		K020103								
	Mix&Match		P171715 P766377	30	P171714 P766377	20	P171713 P766377	20	P171713 P766377	20	P171713 P766377	K020214 P766377	
AP359	Assembly	50	K020110		K020109								
	Mix&Match		P165136 P766378	50	P165006 P766378	40	P165041 P766378	40	P165041 P766378	40	P169429 P766378	not available P766378	
AP360	Assembly	90	K020116		K020115								
	Mix&Match		P165138 P766379	90	P165015 P766379	70	P165043 P766379	70	P165043 P766379	70	P167838 P766379	not available P766379	
			Sparepart Housing		Sparepart Housing		Sparepart Housing		Sparepart Housing		Sparepart Housing		

RMF = Recommended Maximum Flow in liters/minute with use of standard head. non-stock item; MOQ is 25 pcs; ordering only possible via your salescontact

Stock item (check e-commerce for availability)

Pressure Line

High Pressure Filters In-Line FPK02-04



SYNTHETIC MEDIA									
		/03			/02			/01	
		β23 _{µm(c)} ≥ 1000			β11 _{µm(c)} ≥ 1000			β8 _{µm(c)} ≥ 1000	
FPK221	Version	RMF			RMF			RMF	
	Assembly	50	K020173		40	K020172		30	K020171
FPK221	Mix&Match		P766385			P766385		P169446	P766385
	Assembly	50	X770617		40	X779053			
FPK222	Mix&Match		P766385 + P761058			P766385 + P761058			
	Assembly	90	K020177		80	K020176		70	K020175
FPK222	Mix&Match		P766386			P766386		P169798	P766386
	Assembly				80	K020212			K020230
FPK223	Mix&Match				80	P766381		P169798	P766381
	Assembly	180	K041585		150	K041588			K041591
FPK224	Mix&Match		P766382			P766382		P164592	P766382
	Assembly	350	K041586		300	K041589			K041592
FPK225	Mix&Match		P766383			P766383		P164594	P766383
	Assembly	450	K041587		400	K041590			K041593
	Mix&Match		P766384			P766384		P164596	P766384
		Sparepart	Housing + Indicator			Housing + Indicator		Sparepart	Housing + Indicator

RMF = Recommended Maximum Flow in liters/minute with use of standard head. non-stock item; MOQ is 25 pcs; ordering only possible via your salescontact

Stock item (check e-commerce for availability)

Pressure Line

High Pressure Filters In-Line FPK03-04



SYNTHETIC MEDIA									
		/03			/02			/01	
		$\beta_{23, \geq 1000}$			$\beta_{11, \geq 1000}$			$\beta_{8, \geq 1000}$	
Family	Version	RMF		RMF		RMF		RMF	
AP361	Assembly	K030286							
	Mix&Match	P171733 P766427	50	50	K030285 P171732 P766427	40	40	P171731 P766427	K030284
AP362	Assembly	K030289							
	Mix&Match	P171736 P766428	80	80	K030288 P171735 P766428	60	60	P171734 P766428	P766428
AP362 SAE Flange	Assembly	K030292							
	Mix&Match	P171736 P766439	80	80	K030291 P171735 P766439	60	60	P171734 P766439	P766439
AP363	Assembly	K030295							
	Mix&Match	P171739 P766429	120	120	K030294 P171738 P766429	80	80	P171737 P766429	P766429
AP363 SAE Flange	Assembly	K030298							
	Mix&Match	P171739 P766440	120	120	K030297 P171738 P766440	80	80	P171737 P766440	P766440
AP364	Assembly	K040676							
	Mix&Match	P171742 P766430	180	180	K040675 P171741 P766430	160	160	P171740 P766430	P766430
AP364 SAE Flange	Assembly	K040679							
	Mix&Match	P171742 P766441	180	180	K040678 P171741 P766441	160	160	P171740 P766441	P766441
AP365	Assembly	K040682							
	Mix&Match	P171745 P766431	300	300	K040681 P171744 P766431	270	270	P171743 P766431	P766431
AP365 SAE Flange	Assembly	K040685							
	Mix&Match	P171745 P766442	300	300	K040684 P171744 P766442	270	270	P171743 P766442	P766442
AP366	Assembly	K040688							
	Mix&Match	P171748 P766432	400	400	K040687 P171747 P766432	320	320	P171746 P766432	P766432
AP366 SAE Flange	Assembly	K040691							
	Mix&Match	P171748 P766443	400	400	K040690 P171747 P766443	320	320	P171746 P766443	P766443
		Sparepart	Housing		Sparepart	Housing		Sparepart	Housing

RMF = Recommended Maximum Flow in liters/minute with use of standard head. non-stock item; MOQ is 25 pcs; ordering only possible via your salescontact

Stock item (check e-commerce for availability)

Pressure Line

High Pressure Filters In-Line FCK-LC



		/6		/03		/02		/01	
		WIRESH		WIRESH		SYNTHETIC MEDIA		SYNTHETIC MEDIA	
		60µ		β ₂₃ _{µm} ≥ 1000		β ₁₁ _{µm} ≥ 1000		β ₈ _{µm} ≥ 1000	
Family	Version	RMF		RMF		RMF		RMF	
FCK2	Assembly	K010009	2	K010007	2	K010006	2	K010005	
	Mix&Match	P171771 P767138		P171769 P767138		P171768 P767138		P171767 P767138	
FCK5	Assembly	K020124	5	K020122	5	K020121	5	K020120	
	Mix&Match	P171776 P767139		P171774 P767139		P171773 P767139		P171772 P767139	
FCK10	Assembly	K020129	10	K020127	10	K020126	10	K020125	
	Mix&Match	P171781 P767140		P171779 P767140		P171778 P767140		P171777 P767140	
FCK20	Assembly	K030303	20	K030301	20	K030300	20	K030299	
	Mix&Match	P763493 P767141		P763485 P767141		P763489 P767141		P763487 P767141	
		Sparepart	Housing + Indicator	Sparepart	Housing + Indicator	Sparepart	Housing + Indicator	Sparepart	Housing + Indicator

RMF = Recommended Maximum Flow in liters/minute with use of standard head.
 non-stock item; MOQ is 25 pcs; ordering only possible via your salescontact

Stock item (check e-commerce for availability)

Part-number	Family	Page	Part-number	Family	Page	Part-number	Family	Page	Part-number	Family	Page
K041301	SRK-COMBO	77	P163419	DURAMAX – HMK 04	120	P167455	DURAMAX – HMK 04	121	P171518	FIK-FIO	36
K041511	SRK-COMBO	77	P163839	FBK-FRCA	64	P167455	DURAMAX – HMK 05	124	P171518	FIK-FIOT	44
K041528	SRK-COMBO	77	P163839	FBK-FRCA	66	P167455	DURAMAX – HMK 05	125	P171518	FLK-FLS	58
K041535	SRK-COMBO	77	P163839	DURAMAX – HMK 04	120	P167473	DURAMAX – HMK 04	120	P171518	FLK-FLA	94
K041595	SRK-COMBO	77	P163839	DURAMAX – HMK 04	121	P167580	SRK-COMBO	78	P171519	FIK-FIO	36
K041596	SRK-COMBO	77	P163839	DURAMAX – HMK 05	124	P167580	DURAMAX – HMK 04	121	P171519	FIK-FIOT	44
K041597	SRK-COMBO	77	P163839	DURAMAX – HMK 05	125	P167580	DURAMAX – HMK 05	125	P171519	FLK-FLS	58
K041598	SRK-COMBO	77	P164164	FPK 02 & 04 – AP220	134	P167838	FPK 02 – AP280	128	P171519	FLK-FLA	94
K041599	SRK-COMBO	77	P164166	FPK 02 & 04 – AP220	134	P169429	FPK 02 – AP280	128	P171520	FIK-FIO	36
K041600	SRK-COMBO	77	P164168	FPK 02 & 04 – AP220	134	P169446	FPK 02 & 04 – AP220	134	P171520	FIK-FIOT	44
K041601	SRK-COMBO	77	P164172	FPK 02 & 04 – AP220	134	P169447	FPK 02 & 04 – AP220	134	P171520	FLK-FLS	58
K041602	SRK-COMBO	77	P164174	FPK 02 & 04 – AP220	134	P169449	FPK 02 & 04 – AP220	134	P171520	FLK-FLA	94
K041603	SRK-COMBO	77	P164176	FPK 02 & 04 – AP220	134	P169450	FPK 02 & 04 – AP220	134	P171521	FIK-FIO	36
K041604	SRK-COMBO	77	P164375	DURAMAX – HMK 04	120	P169797	FPK 02 & 04 – AP220	134	P171521	FIK-FIOT	44
K041605	SRK-COMBO	77	P164378	DURAMAX – HMK 04	120	P169798	FPK 02 & 04 – AP220	134	P171521	FLK-FLS	58
K041606	SRK-COMBO	77	P164381	DURAMAX – HMK 04	120	P170926	FLK	116	P171521	FLK-FLA	94
K041607	SRK-COMBO	77	P164384	DURAMAX – HMK 04	120	P170926	DURAMAX – HMK 04	120	P171522	FIK-FIO	36
K041608	SRK-COMBO	77	P164592	FPK 02 & 04 – AP220	134	P170926	DURAMAX – HMK 04	121	P171522	FIK-FIOT	44
K041609	SRK-COMBO	77	P164594	FPK 02 & 04 – AP220	134	P170926	DURAMAX – HMK 05	124	P171522	FLK-FLS	58
K041610	SRK-COMBO	77	P164596	FPK 02 & 04 – AP220	134	P170926	DURAMAX – HMK 05	125	P171522	FLK-FLA	94
K041659	SRK-COMBO	77	P165006	FPK 02 – AP280	128	P171087	FLK	116	P171523	FIK-FIO	36
K041660	SRK-COMBO	77	P165015	FPK 02 – AP280	128	P171087	DURAMAX – HMK 04	120	P171523	FIK-FIOT	44
K041661	SRK-COMBO	77	P165041	FPK 02 – AP280	128	P171087	DURAMAX – HMK 04	121	P171523	FLK-FLS	58
K041662	SRK-COMBO	77	P165043	FPK 02 – AP280	128	P171087	DURAMAX – HMK 05	124	P171523	FLK-FLA	94
K041663	SRK-COMBO	77	P165136	FPK 02 – AP280	128	P171087	DURAMAX – HMK 05	125	P171524	FIK-FIO	36
K041664	SRK-COMBO	77	P165138	FPK 02 – AP280	128	P171087	FPK 02 & 04 – AP220	134	P171524	FIK-FIOT	44
K041665	SRK-COMBO	77	P165194	SRK-COMBO	77	P171087	FPK 02 & 04 – AP220	135	P171524	FIK-FIS	52
K041666	SRK-COMBO	77	P165194	SRK-COMBO	78	P171143	DURAMAX – HMK 04	120	P171524	FHK-FIR	70
K041667	SRK-COMBO	77	P165194	DURAMAX – HMK 04	120	P171143	DURAMAX – HMK 04	121	P171525	FIK-FIO	36
K041668	SRK-COMBO	77	P165194	DURAMAX – HMK 04	121	P171143	DURAMAX – HMK 05	124	P171525	FIK-FIOT	44
K041669	SRK-COMBO	77	P165194	DURAMAX – HMK 05	124	P171143	DURAMAX – HMK 05	125	P171525	FIK-FIS	52
K041670	SRK-COMBO	77	P165194	DURAMAX – HMK 05	125	P171500	FIK-FIO	36	P171525	FHK-FIR	70
K041671	SRK-COMBO	77	P165332	DURAMAX – HMK 04	120	P171500	FIK-FIOT	44	P171526	FIK-FIO	36
K041672	SRK-COMBO	77	P165335	DURAMAX – HMK 04	120	P171500	FHK-FIR	70	P171526	FIK-FIOT	44
K041673	SRK-COMBO	77	P165338	DURAMAX – HMK 04	120	P171501	FIK-FIO	36	P171526	FIK-FIS	52
K041674	SRK-COMBO	77	P165354	DURAMAX – HMK 04	120	P171501	FIK-FIOT	44	P171526	FHK-FIR	70
P162400	FBK-FRCA	64	P165569	DURAMAX – HMK 05	124	P171501	FHK-FIR	70	P171527	FIK-FIO	36
P162400	FBK-FRCA	66	P165659	DURAMAX – HMK 05	124	P171502	FIK-FIO	36	P171527	FIK-FIOT	44
P162400	DURAMAX – HMK 04	120	P165672	DURAMAX – HMK 05	124	P171502	FIK-FIOT	44	P171527	FIK-FIS	52
P162400	DURAMAX – HMK 04	121	P165675	DURAMAX – HMK 05	124	P171502	FHK-FIR	70	P171527	FHK-FIR	70
P162400	DURAMAX – HMK 05	124	P165705	DURAMAX – HMK 05	124	P171503	FIK-FIO	36	P171528	FIK-FIO	36
P162400	DURAMAX – HMK 05	125	P167181	FPK 02 – AP280	128	P171503	FIK-FIOT	44	P171528	FIK-FIOT	44
P162696	FBK-FRCA	64	P167183	FPK 02 – AP280	128	P171503	FHK-FIR	70	P171528	FIK-FIS	52
P162696	FBK-FRCA	66	P167186	FPK 02 & 04 – AP220	134	P171504	FIK-FIO	36	P171528	FHK-FIR	70
P162696	DURAMAX – HMK 04	120	P167412	FPK 02 & 04 – AP220	134	P171504	FIK-FIOT	44	P171529	FIK-FIO	36
P162696	DURAMAX – HMK 04	121	P167413	FPK 02 & 04 – AP220	134	P171504	FHK-FIR	70	P171529	FIK-FIOT	44
P162696	DURAMAX – HMK 05	124	P167415	FPK 02 & 04 – AP220	134	P171505	FIK-FIO	36	P171529	FIK-FIS	52
P162696	DURAMAX – HMK 05	125	P167455	SRK-COMBO	77	P171505	FIK-FIOT	44	P171529	FHK-FIR	70
P163324	DURAMAX – HMK 04	120	P167455	DURAMAX – HMK 04	120	P171505	FHK-FIR	70	P171530	FIK-FIO	36

Part-number	Family	Page	Part-number	Family	Page	Part-number	Family	Page	Part-number	Family	Page
P171530	FIK-FIOT	44	P171538	FLK-FLA	94	P171558	FIK-FIOT	44	P171570	FIK-FIOT	44
P171530	FIK-FIS	52	P171539	FIK-FIO	36	P171559	FIK-FIO	36	P171570	FLK-FLS	58
P171530	FLK-FLS	58	P171539	FIK-FIOT	44	P171559	FIK-FIOT	44	P171570	FHK-FIR	70
P171530	FHK-FIR	70	P171539	FLK-FLS	58	P171560	FIK-FIO	36	P171570	FLK-FLA	94
P171530	FLK-FLA	94	P171539	FHK-FIR	70	P171560	FIK-FIOT	44	P171571	FIK-FIO	36
P171531	FIK-FIO	36	P171539	FLK-FLA	94	P171560	FLK-FLS	58	P171571	FIK-FIOT	44
P171531	FIK-FIOT	44	P171540	FIK-FIO	36	P171560	FLK-FLA	94	P171571	FLK-FLS	58
P171531	FIK-FIS	52	P171540	FIK-FIOT	44	P171561	FIK-FIO	36	P171571	FHK-FIR	70
P171531	FLK-FLS	58	P171540	FLK-FLS	58	P171561	FIK-FIOT	44	P171571	FLK-FLA	94
P171531	FHK-FIR	70	P171540	FHK-FIR	70	P171561	FLK-FLS	58	P171572	FIK-FIO	36
P171531	FLK-FLA	94	P171540	FLK-FLA	94	P171561	FLK-FLA	94	P171572	FIK-FIOT	44
P171532	FIK-FIO	36	P171541	FIK-FIO	36	P171562	FIK-FIO	36	P171573	FIK-FIO	36
P171532	FIK-FIOT	44	P171541	FIK-FIOT	44	P171562	FIK-FIOT	44	P171573	FIK-FIOT	44
P171532	FIK-FIS	52	P171541	FLK-FLS	58	P171562	FLK-FLS	58	P171574	FIK-FIO	36
P171532	FLK-FLS	58	P171541	FHK-FIR	70	P171562	FLK-FLA	94	P171574	FIK-FIOT	44
P171532	FHK-FIR	70	P171541	FLK-FLA	94	P171563	FIK-FIO	36	P171575	FIK-FIO	36
P171532	FLK-FLA	94	P171542	FIK-FIO	36	P171563	FIK-FIOT	44	P171575	FIK-FIOT	44
P171533	FIK-FIO	36	P171542	FIK-FIOT	44	P171563	FLK-FLS	58	P171576	FIK-FIO	36
P171533	FIK-FIOT	44	P171543	FIK-FIO	36	P171563	FLK-FLA	94	P171576	FIK-FIOT	44
P171533	FIK-FIS	52	P171543	FIK-FIOT	44	P171564	FIK-FIO	36	P171577	FIK-FIO	36
P171533	FLK-FLS	58	P171544	FIK-FIO	36	P171564	FIK-FIOT	44	P171577	FIK-FIOT	44
P171533	FHK-FIR	70	P171544	FIK-FIOT	44	P171564	FLK-FLS	58	P171578	FIK-FIO	36
P171533	FLK-FLA	94	P171545	FIK-FIO	36	P171564	FLK-FLA	94	P171578	FIK-FIOT	44
P171534	FIK-FIO	36	P171545	FIK-FIOT	44	P171565	FIK-FIO	36	P171578	FLK-FLS	58
P171534	FIK-FIOT	44	P171546	FIK-FIO	36	P171565	FIK-FIOT	44	P171578	FLK-FLA	94
P171534	FIK-FIS	52	P171546	FIK-FIOT	44	P171565	FLK-FLS	58	P171579	FIK-FIO	36
P171534	FLK-FLS	58	P171547	FIK-FIO	36	P171565	FLK-FLA	94	P171579	FIK-FIOT	44
P171534	FHK-FIR	70	P171547	FIK-FIOT	44	P171566	FIK-FIO	36	P171579	FLK-FLS	58
P171534	FLK-FLA	94	P171548	FIK-FIO	36	P171566	FIK-FIOT	44	P171579	FLK-FLA	94
P171535	FIK-FIO	36	P171548	FIK-FIOT	44	P171566	FLK-FLS	58	P171580	FIK-FIO	36
P171535	FIK-FIOT	44	P171549	FIK-FIO	36	P171566	FLK-FLA	94	P171580	FIK-FIOT	44
P171535	FIK-FIS	52	P171549	FIK-FIOT	44	P171566	FHK-FIR	70	P171580	FLK-FLS	58
P171535	FLK-FLS	58	P171550	FIK-FIO	36	P171566	FLK-FLA	94	P171580	FLK-FLA	94
P171535	FHK-FIR	70	P171550	FIK-FIOT	44	P171567	FIK-FIO	36	P171581	FIK-FIO	36
P171535	FLK-FLA	94	P171551	FIK-FIO	36	P171567	FIK-FIOT	44	P171581	FIK-FIOT	44
P171536	FIK-FIO	36	P171551	FIK-FIOT	44	P171567	FLK-FLS	58	P171581	FLK-FLS	58
P171536	FIK-FIOT	44	P171552	FIK-FIO	36	P171567	FHK-FIR	70	P171581	FLK-FLA	94
P171536	FLK-FLS	58	P171552	FIK-FIOT	44	P171567	FLK-FLA	94	P171582	FIK-FIO	36
P171536	FHK-FIR	70	P171553	FIK-FIO	36	P171568	FIK-FIO	36	P171582	FIK-FIOT	44
P171536	FLK-FLA	94	P171553	FIK-FIOT	44	P171568	FIK-FIOT	44	P171582	FLK-FLS	58
P171537	FIK-FIO	36	P171554	FIK-FIO	36	P171568	FLK-FLS	58	P171582	FLK-FLA	94
P171537	FIK-FIOT	44	P171554	FIK-FIOT	44	P171568	FHK-FIR	70	P171583	FIK-FIO	36
P171537	FLK-FLS	58	P171555	FIK-FIO	36	P171568	FLK-FLA	94	P171583	FIK-FIOT	44
P171537	FHK-FIR	70	P171555	FIK-FIOT	44	P171569	FIK-FIO	36	P171583	FLK-FLS	58
P171537	FLK-FLA	94	P171556	FIK-FIO	36	P171569	FIK-FIOT	44	P171583	FLK-FLA	94
P171538	FIK-FIO	36	P171556	FIK-FIOT	44	P171569	FLK-FLS	58	P171584	FLK-FLS	58
P171538	FIK-FIOT	44	P171557	FIK-FIO	36	P171569	FHK-FIR	70	P171584	FLK-FLA	94
P171538	FLK-FLS	58	P171557	FIK-FIOT	44	P171569	FLK-FLA	94	P171585	FLK-FLS	58
P171538	FHK-FIR	70	P171558	FIK-FIO	36	P171570	FIK-FIO	36	P171585	FLK-FLA	94

Part-number	Family	Page	Part-number	Family	Page	Part-number	Family	Page	Part-number	Family	Page
P171586	FLK-FLS	58	P171610	FFCA	158	P171732	FPK 03 & 04 – AP420	140	P171841	FIK-FIS	52
P171586	FLK-FLA	94	P171611	FBK-FRCA	64	P171733	FPK 03 & 04 – AP420	140	P171842	FIK-FIS	52
P171587	FLK-FLS	58	P171611	FBK-FACA	100	P171734	FPK 03 & 04 – AP420	140	P171843	FIK-FIO	36
P171587	FLK-FLA	94	P171611	FFCA	158	P171735	FPK 03 & 04 – AP420	140	P171843	FIK-FIS	52
P171588	FLK-FLS	58	P171612	FBK-FRCA	64	P171736	FPK 03 & 04 – AP420	140	P171844	FIK-FIS	52
P171588	FLK-FLA	94	P171612	FBK-FACA	100	P171737	FPK 03 & 04 – AP420	140	P171845	FIK-FIS	52
P171589	FLK-FLS	58	P171612	FFCA	158	P171738	FPK 03 & 04 – AP420	140	P171846	FIK-FIO	36
P171589	FLK-FLA	94	P171613	FBK-FRCA	64	P171739	FPK 03 & 04 – AP420	140	P171846	FIK-FIS	52
P171590	FLK-FLS	58	P171613	FBK-FACA	100	P171740	FPK 03 & 04 – AP420	140	P171847	TCO	154
P171590	FLK-FLA	94	P171613	FFCA	158	P171741	FPK 03 & 04 – AP420	140	P171848	TCO	154
P171591	FLK-FLS	58	P171614	FBK-FRCA	64	P171742	FPK 03 & 04 – AP420	140	P171850	TCO	154
P171591	FLK-FLA	94	P171614	FBK-FACA	100	P171743	FPK 03 & 04 – AP420	140	P171851	TCO	154
P171592	FLK-FLS	58	P171616	FBK-FRCA	64	P171744	FPK 03 & 04 – AP420	140	P171852	TCO	154
P171592	FLK-FLA	94	P171616	FBK-FACA	100	P171745	FPK 03 & 04 – AP420	140	P171853	TCO	154
P171593	FLK-FLS	58	P171616	FFCA	158	P171746	FPK 03 & 04 – AP420	140	P171854	TCO	154
P171593	FLK-FLA	94	P171617	FBK-FRCA	64	P171747	FPK 03 & 04 – AP420	140	P171855	TCO	154
P171594	FLK-FLS	58	P171617	FBK-FACA	100	P171748	FPK 03 & 04 – AP420	140	P171856	TCO	154
P171594	FLK-FLA	94	P171617	FFCA	158	P171767	FCK-LC	146	P171857	TCO	154
P171595	FLK-FLS	58	P171618	FBK-FRCA	64	P171768	FCK-LC	146	P171858	TCO	154
P171595	FLK-FLA	94	P171618	FBK-FACA	100	P171769	FCK-LC	146	P171859	TCO	154
P171596	FLK-FLA	94	P171618	FFCA	158	P171771	FCK-LC	146	P171860	TCO	154
P171597	FLK-FLS	58	P171619	FBK-FRCA	64	P171772	FCK-LC	146	P171861	FIOA	84
P171597	FLK-FLA	94	P171619	FBK-FACA	100	P171773	FCK-LC	146	P171865	FIOA	84
P171598	FLK-FLS	58	P171620	FBK-FRCA	64	P171774	FCK-LC	146	P171869	FIOA	84
P171598	FLK-FLA	94	P171620	FBK-FACA	100	P171776	FCK-LC	146	P171873	FIOA	84
P171599	FLK-FLS	58	P171620	FFCA	158	P171777	FCK-LC	146	P171877	FIOA	84
P171599	FLK-FLA	94	P171621	FBK-FRCA	64	P171778	FCK-LC	146	P171885	FIOA	84
P171600	FLK-FLS	58	P171621	FBK-FACA	100	P171779	FCK-LC	146	P171889	FIOA	84
P171600	FLK-FLA	94	P171621	FFCA	158	P171781	FCK-LC	146	P171893	FIOA	84
P171601	FLK-FLS	58	P171622	FBK-FRCA	64	P171783	FS	157	P171897	FIOA	84
P171601	FLK-FLA	94	P171622	FBK-FACA	100	P171784	FS	157	P171901	FIOA	84
P171602	FBK-FRCA	64	P171622	FFCA	158	P171785	FS	157	P171905	FIOA	84
P171602	FBK-FACA	100	P171701	FMK-FM	106	P171786	FS	157	P171909	FIOA	84
P171602	FFCA	158	P171702	FMK-FM	106	P171829	FIK-FIS	52	P171913	LVO/LVOT	159
P171604	FBK-FRCA	64	P171703	FMK-FM	106	P171830	FIK-FIS	52	P171914	LVO/LVOT	159
P171604	FBK-FACA	100	P171704	FMK-FM	106	P171831	FIK-FIO	36	P171915	LVO/LVOT	159
P171606	FBK-FRCA	64	P171705	FMK-FM	106	P171831	FIK-FIS	52	P171916	LVO/LVOT	159
P171606	FBK-FACA	100	P171706	FMK-FM	106	P171832	FIK-FIS	52	P171917	LVO/LVOT	159
P171606	FFCA	158	P171706	FCK-LC	110	P171833	FIK-FIS	52	P171918	LVO/LVOT	159
P171607	FBK-FRCA	64	P171707	FMK-FM	106	P171834	FIK-FIO	36	P171919	LVO/LVOT	159
P171607	FBK-FACA	100	P171708	FMK-FM	106	P171834	FIK-FIS	52	P171920	LVO/LVOT	159
P171607	FFCA	158	P171709	FMK-FM	106	P171835	FIK-FIS	52	P171921	LVO/LVOT	159
P171608	FBK-FRCA	64	P171710	FMK-FM	106	P171836	FIK-FIS	52	P171922	LVO/LVOT	159
P171608	FBK-FACA	100	P171711	FMK-FM	106	P171837	FIK-FIO	36	P171944	FMK-FM	106
P171608	FFCA	158	P171712	FMK-FM	106	P171837	FIK-FIS	52	P171944	FMK-FM	107
P171609	FBK-FRCA	64	P171713	FPK 02 – AP280	128	P171838	FIK-FIS	52	P171944	FPK 02 – AP280	128
P171609	FBK-FACA	100	P171714	FPK 02 – AP280	128	P171839	FIK-FIS	52	P171944	FPK 02 – AP280	129
P171610	FBK-FRCA	64	P171715	FPK 02 – AP280	128	P171840	FIK-FIO	36	P171944	FPK 03 & 04 – AP420	140
P171610	FBK-FACA	100	P171731	FPK 03 & 04 – AP420	140	P171840	FIK-FIS	52	P171944	FPK 03 & 04 – AP420	141

Part-number	Family	Page	Part-number	Family	Page	Part-number	Family	Page	Part-number	Family	Page
P171944	FPK 03 & 04 – AP420	142	P171961	FBK-FRCA	64	P173253	TCA	156	P176632	FPK 03 & 04 – AP420	140
P171945	FMK-FM	106	P171961	FBK-FRCA	66	P173259	TCA	156	P176633	FPK 03 & 04 – AP420	140
P171945	FMK-FM	107	P171963	FLK-FLS	59	P173266	TCA	156	P176634	FPK 03 & 04 – AP420	140
P171945	FPK 02 – AP280	128	P171963	FLK-FLS	60	P173385	DURAMAX – HMK 04	120	P176635	FPK 03 & 04 – AP420	140
P171945	FPK 02 – AP280	129	P171963	FBK-FRCA	64	P173386	DURAMAX – HMK 04	120	P176636	FPK 03 & 04 – AP420	140
P171945	FPK 03 & 04 – AP420	140	P171963	FBK-FRCA	66	P173386	DURAMAX – HMK 04	121	P176637	FPK 02 & 04 – AP220	132
P171945	FPK 03 & 04 – AP420	141	P171966	FIK-FIO	37	P173403	FBK-FRCA	64	P176640	FPK 02 & 04 – AP220	132
P171945	FPK 03 & 04 – AP420	142	P171966	FIK-FIO	38	P173403	FBK-FACA	100	P176641	FPK 02 & 04 – AP220	132
P171947	FMK-FM	106	P171966	FIK-FIOT	45	P173438	DURAMAX – HMK 04	120	P176643	FPK 02 & 04 – AP220	132
P171947	FMK-FM	107	P171966	FIK-FIOT	46	P173438	DURAMAX – HMK 04	121	P176644	FPK 02 & 04 – AP220	132
P171947	FPK 02 – AP280	128	P171966	FIK-FIS	53	P173441	FBK-FRCA	64	P176646	FPK 02 & 04 – AP220	132
P171947	FPK 02 – AP280	129	P171966	FIK-FIS	54	P173441	FBK-FRCA	65	P176647	FPK 02 & 04 – AP220	132
P171947	FPK 03 & 04 – AP420	140	P171966	FBK-FRCA	64	P173442	FBK-FACA	100	P176649	FPK 02 & 04 – AP220	132
P171947	FPK 03 & 04 – AP420	141	P171966	FBK-FRCA	66	P173442	FBK-FACA	101	P176650	FPK 02 & 04 – AP220	132
P171947	FPK 03 & 04 – AP420	142	P171966	FHK-FIR	70	P173448	DURAMAX – HMK 05	122	P176846	FBK-FRCA	64
P171950	FLK-FLS	59	P171967	FLK-FLA	95	P173475	TCA	156	P176846	FBK-FRCA	65
P171950	FLK-FLS	60	P171967	FLK-FLA	96	P173893	SRK-COMBO	77	P176903	FAL	94
P171950	FBK-FRCA	64	P171967	FBK-FACA	100	P173893	DURAMAX – HMK 04	120	P176904	FAL	94
P171950	FBK-FRCA	66	P171967	FBK-FACA	102	P173893	DURAMAX – HMK 04	121	P176939	FPK 02 – AP280	128
P171953	FIK-FIO	37	P172381	FS	157	P173893	DURAMAX – HMK 05	124	P176965	FBK-FRCA	64
P171953	FIK-FIO	38	P172382	FS	157	P173893	DURAMAX – HMK 05	125	P177227	FFCA	158
P171953	FIK-FIOT	45	P172383	FS	157	P173918	DURAMAX – HMK 04	120	P177438	LVO/LVOT	159
P171953	FIK-FIOT	46	P172384	FS	157	P173944	FLK-FLS	60	P177439	LVO/LVOT	159
P171953	FIK-FIS	53	P172385	FS	157	P173944	DURAMAX – HMK 04	120	P550148	FBK-FRCA	64
P171953	FIK-FIS	54	P172386	FS	157	P173944	DURAMAX – HMK 04	121	P550148	FBK-FACA	100
P171953	FHK-FIR	70	P172387	FS	157	P173944	DURAMAX – HMK 05	124	P550148	FFCA	158
P171954	FBK-FRCA	64	P172388	FS	157	P173944	DURAMAX – HMK 05	125	P550268	FBK-FRCA	64
P171954	FBK-FRCA	66	P172389	FS	157	P175001	FBK-FACA	100	P550268	FBK-FACA	100
P171954	SRK-COMBO	77	P172433	FS	157	P175017	FBK-FRCA	64	P550268	FFCA	158
P171954	SRK-COMBO	78	P172435	FS	157	P175029	DURAMAX – HMK 04	120	P561138	FBK-FACA	100
P171954	FLK-FLA	95	P172452	FIOA	84	P175095	DURAMAX – HMK 05	124	P561140	FBK-FACA	100
P171954	FLK-FLA	96	P172493	TCA	156	P175142	FAL	94	P561141	FBK-FRCA	64
P171954	FBK-FACA	100	P173104	FIK-FIO	37	P175143	FAL	94	P562261	FBK-FRCA	64
P171954	FBK-FACA	102	P173104	FIK-FIO	38	P175447	FS	157	P562262	FBK-FRCA	64
P171958	FIK-FIO	37	P173104	FIK-FIOT	45	P176613	FPK 02 – AP280	128	P563279	FBK-FRCA	64
P171958	FIK-FIO	38	P173104	FIK-FIOT	46	P176616	FPK 02 – AP280	128	P563280	FBK-FRCA	64
P171958	FIK-FIOT	45	P173104	FIK-FIS	53	P176619	FPK 03 & 04 – AP420	140	P563287	FBK-FRCA	64
P171958	FIK-FIOT	46	P173104	FIK-FIS	54	P176620	FPK 03 & 04 – AP420	140	P563288	FBK-FACA	100
P171958	FIK-FIS	53	P173104	FBK-FRCA	64	P176621	FPK 03 & 04 – AP420	140	P563296	FBK-FRCA	64
P171958	FIK-FIS	54	P173104	FBK-FRCA	66	P176622	FPK 03 & 04 – AP420	140	P563297	FBK-FRCA	64
P171958	FBK-FRCA	64	P173104	FHK-FIR	70	P176623	FPK 03 & 04 – AP420	140	P563298	FBK-FRCA	64
P171958	FBK-FRCA	66	P173105	FLK-FLA	96	P176624	FPK 03 & 04 – AP420	140	P563299	FBK-FACA	100
P171958	FHK-FIR	70	P173105	FLK-FLA	96	P176625	FPK 03 & 04 – AP420	140	P563978	FBK-FRCA	64
P171959	FLK-FLA	95	P173105	FBK-FACA	102	P176626	FPK 03 & 04 – AP420	140	P563979	FBK-FACA	100
P171959	FLK-FLA	96	P173106	FPK 02 – AP280	128	P176627	FPK 03 & 04 – AP420	140	P567392	FIK-FIS	52
P171959	FBK-FACA	100	P173132	DURAMAX – HMK 04	120	P176628	FPK 03 & 04 – AP420	140	P760071	FBK-FRCA	64
P171959	FBK-FACA	102	P173203	FBK-FACA	100	P176629	FPK 03 & 04 – AP420	140	P760151	FIOA	84
P171961	FLK-FLS	59	P173203	FBK-FACA	101	P176630	FPK 03 & 04 – AP420	140	P760682	FFCA	158
P171961	FLK-FLS	60	P173251	TCO	154	P176631	FPK 03 & 04 – AP420	140	P760924	DURAMAX – HMK 04	120

Part-number	Family	Page	Part-number	Family	Page	Part-number	Family	Page	Part-number	Family	Page
P761036	TCA	156	P763668	FBK-FACA	100	P766295	DURAMAX – HMK 04	120	P766456	FIK-FIO	37
P761040	FAL	94	P763672	TCA	156	P766296	DURAMAX – HMK 04	120	P766457	FIK-FIO	37
P761045	FS	157	P763975	FPK 02 & 04 – AP220	135	P766297	DURAMAX – HMK 05	124	P766458	FIK-FIO	37
P761046	FS	157	P763975	FPK 02 & 04 – AP220	136	P766297	DURAMAX – HMK 05	124	P766459	FIK-FIO	37
P761047	FS	157	P763976	FPK 02 & 04 – AP220	135	P766298	DURAMAX – HMK 05	125	P766460	FIK-FIO	37
P761048	FS	157	P763976	FPK 02 & 04 – AP220	136	P766298	DURAMAX – HMK 05	124	P766461	FIK-FIO	37
P761049	FS	157	P763987	FBK-FRCA	64	P766299	DURAMAX – HMK 05	124	P766462	FIK-FIO	37
P761050	FS	157	P763987	FBK-FACA	100	P766377	FPK 02 – AP280	129	P766463	FIK-FIOT	45
P761051	FS	157	P764183	SRK-COMBO	76	P766378	FPK 02 – AP280	129	P766464	FIK-FIOT	45
P761052	FS	157	P764198	SRK-COMBO	76	P766379	FPK 02 – AP280	129	P766465	FIK-FIOT	45
P761053	FS	157	P764198	SRK-COMBO	76	P766380	FPK 02 & 04 – AP220	134	P766466	FIK-FIOT	45
P761054	FS	157	P764322	DURAMAX – HMK 04	120	P766381	FPK 02 & 04 – AP220	134	P766467	FIK-FIOT	45
P761056	FMK-FM	106	P764407	FBK-FRCA	64	P766382	FPK 02 & 04 – AP220	135	P766468	FIK-FIOT	45
P761056	FMK-FM	107	P764408	FBK-FRCA	64	P766383	FPK 02 & 04 – AP220	135	P766469	FIK-FIOT	45
P761056	FPK 02 – AP280	128	P764409	FBK-FRCA	64	P766384	FPK 02 & 04 – AP220	135	P766470	FIK-FIOT	45
P761056	FPK 02 – AP280	129	P764409	FBK-FACA	100	P766385	FPK 02 & 04 – AP220	135	P766471	FIK-FIOT	45
P761056	FPK 03 & 04 – AP420	140	P764410	FBK-FRCA	64	P766386	FPK 02 & 04 – AP220	135	P766472	FIK-FIOT	45
P761056	FPK 03 & 04 – AP420	141	P764410	FBK-FACA	100	P766387	FPK 02 & 04 – AP220	134	P766473	FIK-FIOT	45
P761056	FPK 03 & 04 – AP420	140	P764411	FBK-FRCA	64	P766388	FPK 02 & 04 – AP220	134	P766474	FIK-FIOT	45
P761057	FPK 02 & 04 – AP220	134	P764411	FBK-FACA	100	P766389	FPK 02 & 04 – AP220	134	P766475	FIK-FIOT	45
P761058	FPK 02 & 04 – AP220	134	P764412	FBK-FRCA	64	P766427	FPK 03 & 04 – AP420	141	P766476	FIK-FIOT	45
P761184	TCO	154	P764412	FBK-FRCA	65	P766428	FPK 03 & 04 – AP420	141	P766477	FIK-FIOT	45
P761259	FBK-FACA	100	P764413	FBK-FRCA	64	P766429	FPK 03 & 04 – AP420	141	P766478	FIK-FIOT	45
P761260	FBK-FACA	100	P764414	FBK-FRCA	64	P766430	FPK 03 & 04 – AP420	141	P766479	FIK-FIOT	45
P761262	FBK-FACA	100	P764415	FBK-FRCA	64	P766431	FPK 03 & 04 – AP420	141	P766481	FHK-FIR	71
P761264	FBK-FRCA	64	P764419	FBK-FACA	100	P766432	FPK 03 & 04 – AP420	141	P766482	FHK-FIR	71
P761314	FBK-FRCA	64	P764419	FBK-FACA	101	P766433	FPK 03 & 04 – AP420	140	P766483	FHK-FIR	71
P761378	DURAMAX – HMK 04	120	P764420	FBK-FACA	100	P766434	FPK 03 & 04 – AP420	140	P766484	FLK-FLA	95
P761392	FPK 02 – AP280	128	P764421	FBK-FRCA	64	P766435	FPK 03 & 04 – AP420	140	P766485	FLK-FLA	95
P761446	DURAMAX – HMK 05	124	P764421	FBK-FACA	100	P766436	FPK 03 & 04 – AP420	140	P766486	FLK-FLA	95
P762065	TCA	156	P764431	SRK-COMBO	77	P766437	FPK 03 & 04 – AP420	140	P766487	FLK-FLA	95
P762421	SRK-COMBO	80	P764431	SRK-COMBO	78	P766438	FPK 03 & 04 – AP420	140	P766488	FLK-FLA	95
P762554	DURAMAX – HMK 04	120	P764612	SRK-COMBO	77	P766439	FPK 03 & 04 – AP420	140	P766489	FLK-FLA	95
P762638	FBK-FRCA	64	P764612	SRK-COMBO	78	P766440	FPK 03 & 04 – AP420	140	P766490	FLK-FLA	95
P762638	FBK-FACA	100	P764613	SRK-COMBO	77	P766441	FPK 03 & 04 – AP420	140	P766491	FLK-FLA	95
P762641	FBK-FRCA	64	P764613	SRK-COMBO	78	P766442	FPK 03 & 04 – AP420	140	P766492	FLK-FLA	95
P762801	DURAMAX – HMK 04	120	P764638	FBK-FRCA	64	P766443	FPK 03 & 04 – AP420	140	P766493	FLK-FLA	95
P762982	DURAMAX – HMK 04	120	P764638	FBK-FACA	100	P766444	FPK 03 & 04 – AP420	140	P766494	FLK-FLA	95
P763139	DURAMAX – HMK 04	120	P765208	FIOA	85	P766445	FPK 03 & 04 – AP420	140	P766495	FLK-FLA	95
P763478	FIOA	84	P765457	SRK-COMBO	76	P766446	FIK-FIO	37	P766528	FIK-FIS	52
P763485	FCK-LC	146	P765457	SRK-COMBO	76	P766447	FIK-FIO	37	P766530	FIK-FIS	52
P763487	FCK-LC	146	P765539	FBK-FRCA	64	P766448	FIK-FIO	37	P766538	FIK-FIS	52
P763489	FCK-LC	146	P765583	FBK-FRCA	64	P766449	FIK-FIO	37	P766552	FIK-FIS	52
P763493	FCK-LC	146	P765584	FBK-FRCA	64	P766450	FIK-FIO	37	P766595	FIK-FIS	53
P763513	TCA	156	P765639	FBK-FRCA	64	P766451	FIK-FIO	37	P766597	FIK-FIS	53
P763528	TCA	156	P766293	FBK-FRCA	64	P766452	FIK-FIO	37	P766598	FIK-FIS	53
P763643	SRK-COMBO	76	P766293	FBK-FRCA	69	P766453	FIK-FIO	37	P766599	FIK-FIS	53
P763652	SRK-COMBO	76	P766294	FBK-FACA	100	P766454	FIK-FIO	37	P766606	FIK-FIS	52
P763668	FBK-FRCA	64	P766294	FBK-FACA	101	P766455	FIK-FIO	37	P766607	FIK-FIS	52

Part-number	Family	Page	Part-number	Family	Page
P766608	FIK-FIS	52	P767031	TRAP BREATHER	150
P766609	FIK-FIS	52	P767138	FCK-LC	147
P766610	FIK-FIS	52	P767139	FCK-LC	147
P766611	FIK-FIS	52	P767140	FCK-LC	147
P766618	FIK-FIS	53	P767141	FCK-LC	147
P766619	FIK-FIS	53			
P766620	FIK-FIS	52			
P766621	FIK-FIS	52			
P766623	FIK-FIS	52			
P766624	FIK-FIS	52			
P766638	FIOA	85			
P766660	FMK-FM	107			
P766661	FMK-FM	107			
P766662	FLK-FLS	59			
P766663	FLK-FLS	59			
P766664	FLK-FLS	59			
P766665	FLK-FLS	59			
P766666	FLK-FLS	59			
P766667	FLK-FLS	59			
P766668	FLK-FLS	59			
P766669	FLK-FLS	59			
P766670	FLK-FLS	59			
P766671	FLK-FLS	59			
P766672	FLK-FLS	59			
P766673	FLK-FLS	59			
P766674	FIK-FIOT	45			
P766675	FIK-FIO	37			
P766678	FHK-FIR	71			
P766679	FHK-FIR	71			
P766847	Filter Cart	152			
P766849	Filter Cart	152			
P766927	FIK-FIS	52			
P766995	FLK-FLS	59			
P766996	FLK-FLS	59			
P766997	FLK-FLS	59			
P766998	FLK-FLS	59			
P766999	FLK-FLS	59			
P767000	FLK-FLS	59			
P767001	FLK-FLS	59			
P767002	FLK-FLS	59			
P767003	FLK-FLS	59			
P767004	FLK-FLS	59			
P767005	FLK-FLS	59			
P767006	FLK-FLS	59			
P767019	TRAP BREATHER	150			
P767021	TRAP BREATHER	150			
P767023	TRAP BREATHER	150			
P767027	TRAP BREATHER	150			
P767029	TRAP BREATHER	150			

Mix&Match

Your flexible hydraulic filtration solutions



Donaldson
FILTRATION SOLUTIONS

EUROPEAN HEADQUARTERS

Donaldson Europe B.V.B.A. / Phone +32 16 38 38 11

OFFICES

Donaldson France S.A.S / Bron - France
Phone +33 47 21 41 840

Donaldson Ibérica, Soluciones en Filtración, S.L. / Madrid - Spain
Phone +34 91 676 86 68

Donaldson Filter Components Ltd. / Hull - UK
Phone +44 14 82 83 52 13

Donaldson Filtration Deutschland GmbH / Dülmen - Germany
Phone +49 2594 78153 / +49 2594 78126

Donaldson Italia SRL / Ostiglia (Mantova) - Italy
Phone +39 0386 30211

Donaldson Sweden / Bromma - Sweden
Phone +46 8 471 8660

Donaldson Filtre Sist. Tic. Ltd. / Istanbul - Turkey
Phone +90 (212) 244 73 31

Donaldson CZ/PL/SK/ Warszawa - Poland
Phone +420 773 795798

Donaldson rep office Bulgaria / Sofia, Bulgaria
Phone +359 2 4914050

Donaldson Czech Republic / Klasterec - Czech Republic
Phone +420 (0) 474319921

Representative office of Donaldson Nederland B.V. / Moscow - Russia
Phone +7 499 13 600 13



Scan for digital
Mix&Match catalogue

Engine-europe@donaldson.com
www.donaldson.com

**European Technical Hydraulic Catalogue
Catalogue No. F116023 (12/14)**